

Braking Devices
VB 230/400-6/25/30L (LP)
Assembly- and Commissioning Instructions

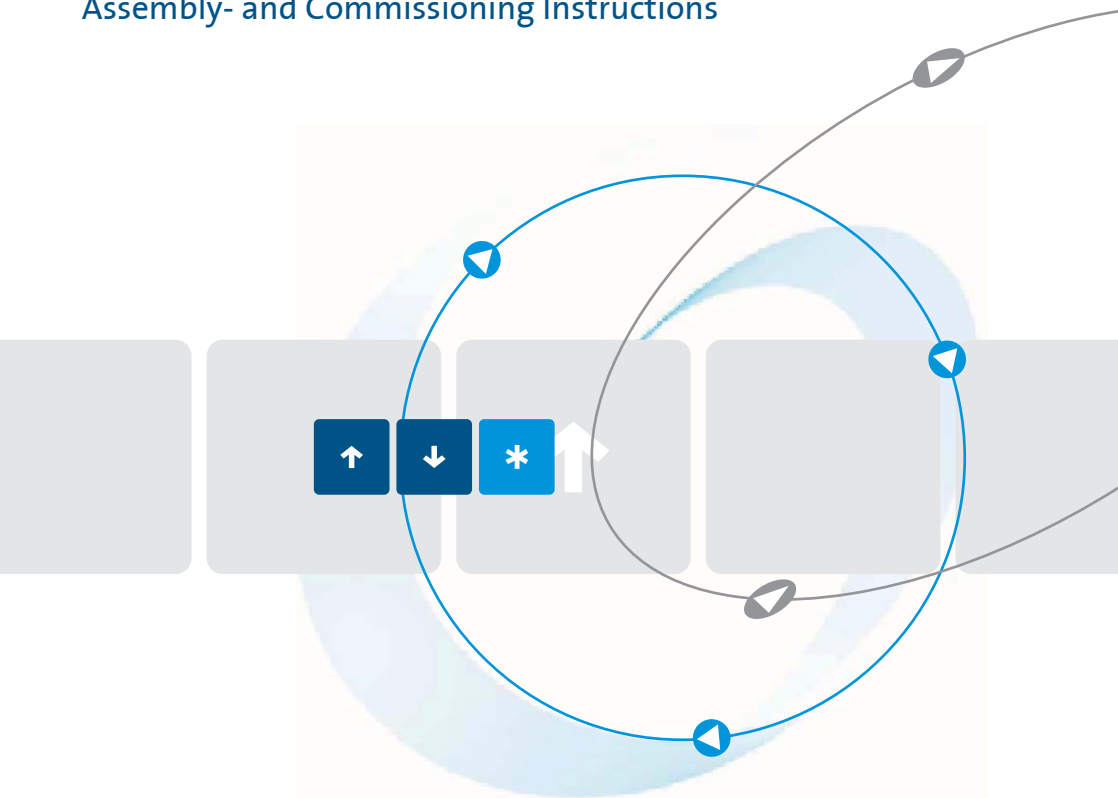

as per 04/10 1B000.10001

Table of Contents	Page
1. Safety notes	3
2. Conformity	3
3. General description	4
4. Usage to the intended purpose	4
5. EC Declaration of Conformity	5
6. Block diagram	6
7. Functional description (see connection diagram)	7
7.1 LED indicators	8
7.2 Fault signaling relay (only available with circuit-board version)	8
8. Control inputs and outputs	9
8.1 Control input	9
8.2 Control outputs	10
9. Potentiometers	11
10. Technical data	12
10.1 Environmental conditions	12
11. Commissioning	13
11.1 Mounting instructions	13
11.2 Connection	13
11.3 Parameter settings	14
11.4 Possible fault indications during commissioning	16
12. Dimensioning rules	17
12.1 Dimensioning of braking contactors	17
12.2 Dimensioning of pre-fuses	17
12.3 Permissible braking frequency	19
13. Dimensions	22
14. Typical connections	23
14.1 Connection diagram	23

These commissioning instructions were prepared with great care. Nevertheless, PETER electronic GmbH & Co. KG does not assume liability for damage resulting from mistakes possibly contained in this manual. Technical changes that serve to improve the product are subject to change without notice.

Notes and symbols used in these instructions

Note: Notes explain the advantages of certain adjustments or settings and help you to make use of the device in the best possible way.



Warning notices: Read them carefully and follow them strictly!

Warning notices are indicated in order to protect you against danger or to help you to prevent the device from being damaged.



Caution: Danger to life through electric shock!

When you see this sign, always make sure that the device is de-energized and secured against unintentional energizing.

1. Safety notes



The described devices are electrical equipment for use in industrial electrical power installations. An impermissible removal of the covers during operation can cause serious damage to your health, since these devices contain live parts with high voltages.

Adjustment work may only be performed by trained staff observing the safety regulations. Assembly and mounting work may only be carried out with the equipment deenergized.

Make sure that all drive components are properly earthed.

Please read these commissioning instructions carefully before putting the device into operation.

Besides, the user must ensure that the devices and associated components are fitted and connected in accordance with the applicable local, legal and technical regulations. The VDE-regulations VDE 0100, VDE 0110 (EN 60664), VDE 0160 (EN 50178) , VDE 0113 (EN 60204, EN 61310),VDE 0660 (EN 50274) plus the appropriate regulations of the TÜV (Technical Control Association) and the trade associations apply in Germany.

The user must ensure that the drive turns into a safe operating state following a device failure, in the event of maloperation, or if the control unit has failed etc..

Caution: Even if the motor is at rest, it is **not** physically separated from the mains.

2. Conformity

In industrial linguistic usage the electronic brakes of the type series VersBrake...-L (LP) are called „devices“, however, in the sense of the „law on the safety of equipment“, the „EMC-law“ or the „EC machinery directive“ they are not devices or machines ready for use or connection but they are components. It is only possible to define their final function, when these components are integrated into the design and construction of the user.

To be able to use the devices to their intended purpose, it requires power supply networks according to DIN EN 50160 (IEC38).

The user takes the responsibility that the user's design and construction comply with the applicable legal provision.

The commissioning is strictly forbidden as long as the conformity of the final product with the guidelines 2006/42/EC (Machinery directive) and 2006/95/EC (Low voltage directive) is not proved.

3. General description

The electronic braking devices of the VersiBrake-L-type are available both as a housing version and as a circuit-board version (LP). They enable non-wearing braking of three-phase asynchronous motors and mono-phase motors. The braking devices are used for drives that, due to safety and functional reasons, have to be reliably slowed down. Braking is initiated by measuring the motor voltage. It is not necessary to connect the motor contactor contact, but this is possible if double detection (redundant system) is required. An integrated standstill detection function switches the braking current off after the motor has come to a standstill. In the case of motor braking times larger than 3 s, this also functions without leading the third motor phase (6T3-terminal) back.

Various fault conditions are indicated via LEDs and, in the case of the circuit-board version, additionally via a fault signalling contact.

Special features

- controlled by microcontroller
- wear-resistant and maintenance-free
- for three-phase asynchronous motors
- for mono-phase motors
- retrofitting into existing plants possible
- no normally closed contact on motor contactor required
- integrated braking contactor
- printed circuit-board version with fault signalling contact
- automatic remanence time optimization
- integrated motor standstill detection
- integrated overload monitoring
- braking current control
- meets trade association requirements for category 2 according to EN 954-1 according to the test principles of woodworking machines GS-HO-01

4. Usage to the intended purpose

The devices of the VersiBrake...-L (LP)-series are electrical equipment that is used in industrial electrical power installations. They are designed for application in machines, in order to slow down rotating masses on drives with three-phase a.c. motors.

Typical applications

- sawing machines
 - centrifuges
 - wood working machines
 - conveying systems
 - textile machines
-

5. EC Declaration of Conformity

EC Declaration of Conformity 

The manufacturer / company placing the product on the market
(authorized representatives of the manufacturer / companies placing the product on the market
that are established within the Community)

Name / Address: Peter Electronic GmbH & Co.KG
Bruckäcker 9
92348 Berg
Germany

hereby declares that the following product (device, component, unit) in the version as supplied

Product designation: Braking Device
Serien / type designation: VB 230/400-6/25/30L (LP)
Article group: 2B0..., 2B1...
Year of manufacture: 2005

complies with the provisions of the following EC-directives:

2004/108/EG concerning Electromagnetic compatibility and **2006/95/EG** concerning Electrical equipment designed for use within certain voltage limits

The following harmonized standards have been applied:

EN 60947-1: 2008	Low-voltage switchgear and controlgear General rules	EN 60947-4-2: 2007	Low-voltage switchgear and controlgear Contactors and motor-starters - AC semiconductor motor controllers and starters
------------------	---	--------------------	--

This EC Declaration of Conformity is no longer valid, if the products is modified or changed without our agreement.

This declaration is issued under the sole responsibility of the signatory.

Berg, 05.08.2009
(place, date)

Dr. Thomas Stiller, Managing Director
(signatory and function of the signatory)

(signature)

6. Block diagram

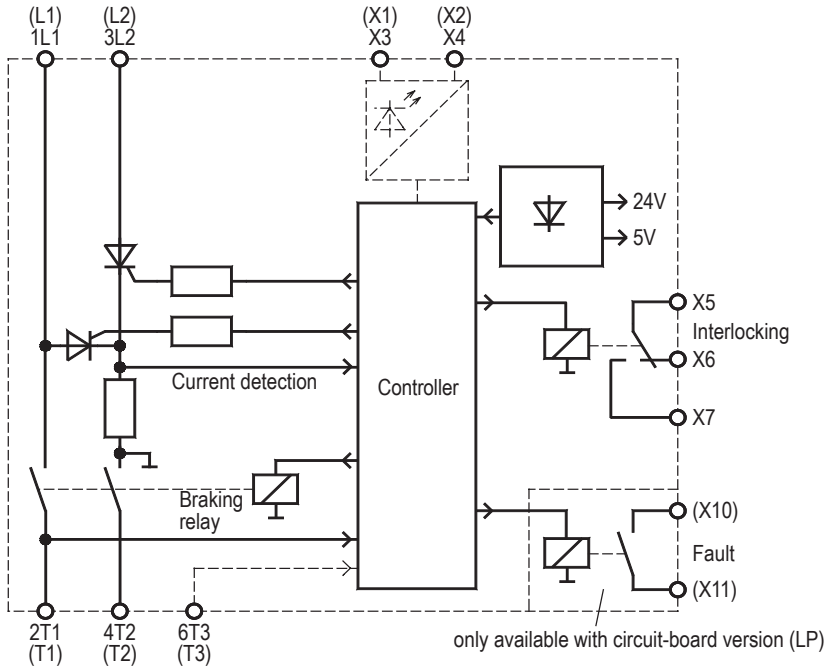

7. Functional description (see connection diagram)

Explanation: The designations for the housing variant are indicated without brackets, whereas those applicable for the circuit-board version are put into brackets.

After the operating voltage on 1L1 (L1) and 3L2 (L2) has been switched on, the main contactor interlock X5 (X5), X6 (X6) and, in the case of the circuit-board version, the fault signaling contact (X10), (X11) closes. The motor can be started.

A starting logic makes sure that, when switching the plant on with the master switch while the motor is still switched off, braking is not initiated.

The fully automatic run of the braking interval starts when a drop of the motor voltage is detected on the terminals 2T1 (T1), 4T2 (T2) and 6T3 (T3). During braking, the main contactor is interlocked via the contact X5 (X5), X6 (X6). After a delay time which, dependent on the amount of the remanent voltage of the motor, optimizes itself, the integrated braking relay pulls in. After the contact bounce time has been waited out, a controlled d.c. current is fed into the motor winding. The magnetic field resulting from this has a braking effect on the still rotating rotor. The d.c. current is generated by a thyristor phase control. Special suppressor circuits protect the power semiconductors against overvoltage. With the potentiometer I (P2), the braking current (and thus the braking torque) can be adjusted within a range of 10 ... 100% of the rated device current. The integrated motor standstill detection, which, if the 6T3 (T3)-terminal is connected, functions via the amount of the remanent voltage and, if the 6T3 (T3)-terminal is not connected, via the brake current waveform, switches the braking current off approx. 1.5s after a motor standstill has been detected. To be able to adapt the device to a variety of motors, it is possible to adjust the standstill threshold via the potentiometer n0 (P1).

Faults, that occur during braking, are indicated via a signaling light (LED), and, in the case of the circuit-board version, additionally via a fault signaling output (X10), (X11).

If more safety (redundant system) is required for initiating braking, it is possible to additionally connect a normally closed contact of the motor contactor to the terminals X3 (X1), X4 (X2). Then, braking will be initiated by two processes which are independent of each other.



Warning:

To ensure a reliable standstill detection function, it is necessary to comply with the following: The braking current must not exceed (3) three times the amount of the rated motor current. If the VB-L is operated without the 6T3 (T3)-terminal being connected, which always applies in the case of single-phase applications, it is to be ensured that braking current flows at least for a period of 1.5 s before the motor comes to a standstill, as no motor standstill is detected within this period of 1.5s and the braking current would then flow over the total maximum braking time. This could cause destruction of the motor and fault indications of the braking device.

Note: If the braking time at rated device current is too short, due to the fact that the centrifugal masses to be slowed down are too large, either a device with a longer braking time can be inquired of the producer or a device featuring a higher rated current has to be used.

7.1 LED indicators

LED – ready (V9) <ul style="list-style-type: none"> - Illuminated - Flashing 1x^a - Flashing 2x^a - Flashing 3x^a - Flashing 5x^a 	Operational status <ul style="list-style-type: none"> - Mains voltage is applied, braking device is ready - No motor standstill detected during max. braking time - Adjusted braking current was not reached - Braking frequency too high - 3x in succession no motor stillstand detected
---	---

a. ... repeated with a short pause

LED – I (V16) <ul style="list-style-type: none"> - Illuminated 	Operational status <ul style="list-style-type: none"> - Braking current is flowing
--	--

7.2 Fault signaling relay (only available with circuit-board version)

The following states on the fault signaling contact (X10), (X11) are possible:

No voltage applied to VB-L	Kontakt (X10), (X11) open
Voltage applied to VB-L, no fault	Kontakt (X10), (X11) closed
No standstill during the max.braking time	Kontakt (X10), (X11) open ^a
Adjusted braking current was not reached	Kontakt (X10), (X11) open ^a
Braking frequency too high	Kontakt (X10), (X11) open ^b
3x no standstill during monitoring time	Kontakt (X10), (X11) open ^b

a. Fault is reset when restarting the motor (voltage on T1, T2, T3).

b. Fault is reset by shortly disconnecting (5s) the mains voltage on L1, L2.

8. Control inputs and outputs

8.1 Control input

Control terminals	Designation	Description
X3 (X1), X4 (X2)	Starting contact	Connection of a normally closed contact of the motor contactor. In standard applications not required. Connection is only required, if more safety is required (redundant system) to initiate braking.

Information on operation without connected starting contact:

The braking delay time (remanence time) may prolong itself by up to 50%.

The interlocking relay does not open immediately after the motor contactor has dropped out, but only shortly before the braking relay closes. In contrast to an operation with connected starting contact this means that the motor can be restarted during the braking delay time (remanence time).



Caution: Danger to life through electric shock!

The terminals X3 (X1), X4 (X2) carry mains potential; when laying the connecting lines, be sure to provide protection against accidental contact.

8.2 Control outputs

Control terminals	Designation	Description
X5 (X5), X6 (X6), X7 (X7)	Interlock (potential-free changeover contact, common contact on X5)	During braking, the contact between X5 and X6 is open. This contact is to be looped into the control circuit of the motor contactor. Therefore, the motor cannot be started during braking. The contact between X5 and X7 is closed during braking. Thus, it is, e.g. in the case of star-delta-connections, possible during braking to control the star contactor in order to interconnect the motor winding. For more detailed information, please see connection diagram on page 20.
(X10), (X11)	Fault signal (potential-free relay contact)	In case of a fault this contact opens. For closer details on the tripping characteristics please see chapter 5.2., page 7. This contact is only available with the circuit-board version.

Behavior of the changeover contact on X5, X6, X7

Status	Interlocking contact X5 – X6	Star contactor contact X5 – X7	Reset by
Motor off	closed	open	
Motor is running	closed	open	
Motor is being decelerated	open	closed	
Braking correctly finished	closed	open	
Braking frequency too high	open S02, S05 closed	closed S02, S05 open	short disconnection from mains (5s)
3x no standstill during max. braking time	open S02, S04 closed	closed S02, S04 open	short disconnection from mains (5s)

9. Potentiometers

With the potentiometers it is possible to adjust the following parameters. The designations for the circuit-board version (LP) are indicated in brackets ().

„I“, „(P2)“

Adjusting the braking current.

The braking current can be adjusted in the range from approx. 10% - 100% of the rated device current. The adjustment is roughly linear.

„n0“, „(P1)“

Adapting the standstill threshold and braking behavior at motor standstill.

With this potentiometer it is possible to adapt the motor standstill threshold to various motor types and applications and to influence the behavior of the braking current at motor standstill.

In „left stop“ (full counter-clockwise) position, the standstill detection function is most sensitive, and the braking behavior, upon reaching the motor standstill, is most soft. Possibly, the braking current is switched off even before the motor has come to a standstill. The potentiometer has to be adjusted so that the braking current is switched off approx. 1-1.5s after the motor has come to a standstill.

Factory-setting: approx. 40%.

Note!

If the potentiometer is adjusted to a position too far in clockwise or counter-clockwise direction (e.g., end stop position), it may happen that no standstills are detected. In this case, braking current flows until the end of the max. braking time. The LED indicates „no standstill during the max. braking time“.

10. Technical data

Type designation	VB 230-6 L (LP)	VB 230-25 L (LP)	VB 230-30 L (LP)	VB 400-6 L (LP)	VB 400-25 L (LP)	VB 400-30 L (LP)
Mains voltage according to DIN EN 50160 (IEC 38)	220/240V \pm 10% 50/60Hz			380/415V \pm 10% 50/60Hz		
Power draw of electronics	3 VA					
Recommended for rated motor currents up to	0,3...3A	2...12.5A	2...15A	0,3...3A	2...12.5A	2...15A
Rated device current	6A	25A	30A	6A	25A	30A
c.d.f. at max. braking current	60%	8%	5%	60%	8%	5%
I ² t -value of power semiconductors	310 A ² s	1250 A ² s	1350 A ² s	310 A ² s	1250 A ² s	1350 A ² s
Braking voltage	0 ... 110VDC			0 ... 220VDC		
max. Braking time	12s					
Contact rating of output relays	3A/250V AC 3A/24VDC					
Delay time for reduction of residual e.m.f.	self-optimizing 0.2 ... 2s					
max. Cross-sectional area for connection - Enclosed version (w. housing): - Circuit-board version:	2 x 2.5mm ² per terminal FASTON connector 6.3 x 0.8mm					

10.1 Environmental conditions

Storage temperature	-25 ... 75°C
Operating temperature	0 ... 45°C
Degree of protection - Enclosed version (w. housing): - Circuit-board version:	IP 20 IP 00
Environment	Overvoltage category III, pollution degree 2
Weight - Enclosed version (w. housing): - Circuit-board version:	0.6kg 0.25kg

11. Commissioning

The device is to be put into operation in 3 steps:

1. Mounting
2. Connection and
3. Parameter setting

11.1 Mounting instructions



Caution: Danger to life through electric shock!

The following conditions are to be complied with in order to ensure a safe and reliable operation of the VersiBrake...-L (LP).

1. The device series VersiBrake...-L (LP) is to be used under overvoltage conditions of the category III.
2. Make sure that pollution degree 2 or better, in accordance with IEC664, is complied with.
3. The device is to be installed into a housing (min. degree of protection: IP54).
4. The device must be operated without being exposed to contamination by water, oil, carbon deposits, dust, etc..



Warning:

Make sure that a minimum distance to adjoining devices is kept. Above and underneath the housing a minimum distance of 50mm is to be kept.

11.2 Connection

The braking device is to be installed according to the attached connection diagram. For other connections please consult PETER electronic GmbH & Co. KG.

Note: Further connection proposals for special circuit arrangements are available via our homepage at www.peter-electronic.com.

Note: Prior to putting the motor brake into operation the wiring is to be checked.

To ensure reliable function is it necessary to comply with the interlocking conditions:

The interlocking contact of the braking device, terminal X5 (X5), X6 (X6), has to be looped into the control circuit of the motor contactor, in order to **prevent** the motor contactor from pulling in during braking.

11.3 Parameter settings

Sequence of steps during commissioning:

(the designations/details indicated in brackets refer to the circuit-board version)

1. Disconnect the plant/system from the supply mains.
2. Adjust the requested braking current with the potentiometer „I“, „(P2)“.
Since the potentiometer reacts roughly linear, it is possible to infer the braking current from the potentiometer setting.
Left stop (counter-clockwise direction) roughly equals 10% of the rated device current.
Mid-position roughly equals 50% of the rated device current.
Right stop (clockwise direction) equals 100% of the rated device current.
3. Adjust potentiometer „n0“, „(P1)“ to approx. 40%.
4. Switch on the plant.
5. Initiate braking by switching the motor ON/OFF.

Note: When putting the device into operation for the first time, the braking current can be checked with a true r.m.s. measuring instrument.

Adjusting the braking current

The braking current is to be adjusted to a value as small as possible, in order to avoid unnecessary heating of the power semiconductors and motor. This is especially important in the case of high switching frequencies. We recommend to limit the max. braking current to 2.5 times the rated motor current.

The requested braking torque can be adjusted with the potentiometer „I“, „(P2)“.

Adjusting the braking time

No adjustments are required, since the braking current is automatically switched off approx. 1.5s after a motor standstill has been detected.

If no standstill is detected during the max. braking time (10s in the case of standard devices), the braking current is switched off when this time is over. This case is indicated by the LED „ready“, „(V9)“ (flashing 1x).

Adjusting the standstill threshold

In most applications, the factory-setting (40%) produces good results.

If the braking current is switched off before the motor has come to a rest, or if the braking current is not switched off approx. 1.5s after the motor has come to a rest, it is possible to make an adjustment with this potentiometer. The optimum setting has to be found by carrying out several braking operations. The potentiometer should be changed only in little steps (10%). For a more detailed functional description please refer to page 9.

**Warning:**

If the 6T3-terminal is not connected, the motor has to be supplied with current for a period of at least 1.5s prior to the standstill. During this period of 1.5s no motor standstill is detected. The braking current then flows until the maximum braking time has elapsed. If this is the case, the braking current has to be adjusted to a slightly lower value.

11.4 Possible fault indications during commissioning

During commissioning, and in normal operation too, fault indications can occur. The following explanation is to give you assistance in the localization and correction of faults.

Fault indication on LED „Ready“, „(V9)“	Fault	Possible cause	Fault correction
Flashing 1x	No motor standstill during max. braking time	Braking current adjusted to a too small value.	Adjust braking current to a higher value.
		Too large centrifugal mass.	Use a braking device with longer max. braking time or higher rated device current.
		Terminal „6T3“ „(T3)“ is not connected and the motor is not supplied with current for a period of 1,5s prior to the standstill.	If possible, connect 6T3 (T3) or adjust the braking current to a slightly lower value.
		Standstill threshold is not adapted.	Adapt standstill threshold with „n0“.
Flashing 2x	Adjusted braking current was not reached.	Interruption in the braking circuit. Possibly the motor is started with star-delta connection.	Check circuit. Possibly the star contactor has to be closed during braking.
		The resistance of the motor winding is too high for the adjusted braking current.	Turn braking current back so that the fault does not occur any more.
Flashing 3x	Braking device is overloaded. Braking frequency is too high.	The specified max. braking frequency is exceeded.	Reduce braking current or braking frequency. During commissioning, 4 braking operations in succession can be initiated without an overload being indicated.
Flashing 5x	3x in succession no standstill detected	Braking current adjusted to a too small value.	Adjust braking current to higher value.
		Centrifugal mass is too large.	Use braking device with longer max. braking time or higher rated device current.
		Cable „6T3“ „(T3)“ is not connected.	Connect or check cable.
		Standstill threshold is not adapted.	Adapt standstill threshold with „n0“.

Note: All data sheets and commissioning instructions are available via our homepage at www.peter-electronic.com.

12. Dimensioning rules

Note! All data sheets and commissioning instructions are available on our homepage at www.peter-electronic.com.

12.1 Dimensioning of braking contactors

The braking contactor is switched on or off via a control contact of the braking device (no-load switching).

When selecting the braking contactor, it must be ensured that the contacts are able to carry the maximally occurring braking current (nominal/rated device current). Therefore, the value „conventional thermal current“ (I_{th}) is decisive when selecting the braking contactor.

If this value is not indicated, the rated operational current for AC1-operation may be used instead.

Tip: By connecting contacts in parallel it is often possible to use a lower-priced contactor of a smaller design.

12.2 Dimensioning of pre-fuses

Basically, two types of fuse protection are available for the user.

1. Fusing according to allocation type „1“, DIN EN 60947-4-2.
After a short circuit, the braking device is allowed to be inoperative.
2. Fusing according to allocation type „2“, DIN EN 60947-4-2.
After a short circuit, the braking device must be suitable for further use. However, there is the danger that the contacts of the braking relay (braking contactor) weld. Therefore, if possible, these contacts are to be checked prior to applying again mains voltage to the device. If this check cannot be carried out by the user, the device has to be returned to the producer in order to have it checked.

The following dimensioning information refers to the below operating conditions:

- Use of standard asynchronous motors
- Braking time not exceeding 20s
- Braking current not exceeding $2.5 \times I_{NOM}$ of the motor.
- Cyclic duration factor (c.d.f.) not exceeding the value indicated in the data sheet.

Fusing according to allocation type „1“:

As pre-fuses, we recommend to use line protection fuses (utilization category gL) or automatic circuit breakers with tripping characteristic B, C, D or K.

Taking into account the maximum braking currents that occur (normally the rated device current), we recommend fuses according to table 2, column 3.

Note: Wiring cross-sectional area according to DIN VDE 0100-430, DIN EN 57100-430.

Fusing according to allocation type „2“:

The power semiconductors are to be protected by fuses of the utilization category gR (semiconductor fuses, high-speed fuses). However, since these fuses do not ensure line protection, it is necessary to use additionally line protection fuses (utilization category gL).

As for the dimensioning of the line protection fuse (gL), please refer to table 2, column 3.

To protect the semiconductors it is necessary to select gR-fuses featuring cutoff- I^2t -values of the ranges indicated in table 2, column 4. In this connection, the fuse rating of the selected fuse should not be smaller than the braking current to be expected (rated device current).

Note 1: On the basis of the recommended I^2t -value, braking current, and possibly the c.d.f., the fuse supplier is able to select a suitable type. Due to the great variety of producers, sizes, and types, PETER electronic does not recommend any particular fuses.

Note 2: If the fuse or cutoff- I^2t -value is selected too small, it may happen that the semiconductor fuse reacts during braking.

Column 1	Column 2	Column 3	Column 4
max. Braking current / Rated device current	Device type	Fuse value in the case of allocation type 1	Recommended range for cutoff- I^2t -value of semiconductor protection fuses in the case of allocation type „2“
6A	VB ...-6L (LP)	6A	150... 250 A ² s
25A	VB ...-25L (LP)	20A	500... 900 A ² s
30A	VB ...-30L (LP)	25A	600... 900 A ² s

Table 2

12.3 Permissible braking frequency

The braking frequency depends on the adjusted braking current.

The braking devices of the VB ...-25 L (LP) type allow the following braking frequencies:

	Braking current	Braking time	Braking frequency
VB ...-6 L	6A	5s 10s	1 braking operation per 8s 1 braking operation per 16s
VB ...-6 L	3A	5s 10s	1 braking operation per 5s 1 braking operation per 10s
VB ...-30 L	30	5s 10s	1 braking operation per 90s 1 braking operation per 180s
VB ...-25,30 L	25A	5s 10s	1 braking operation per 60s 1 braking operation per 120s
VB ...-25,30 L	20A	5s 10s	1 braking operation per 40s 1 braking operation per 80s
VB ...-25,30 L	15A	5s 10s	1 braking operation per 25s 1 braking operation per 50s
VB ...-25,30 L	10A	5s 10s	1 braking operation per 17s 1 braking operation per 35s

For intermediate values please refer to table 3.



Warning:

When setting up a machine or during commissioning, it is possible to carry out 4 braking operations in succession, i.e., with rated device current and at a braking time of 10s. After such operating conditions, however, the device needs a recovery time of 15 minutes.

Table 3

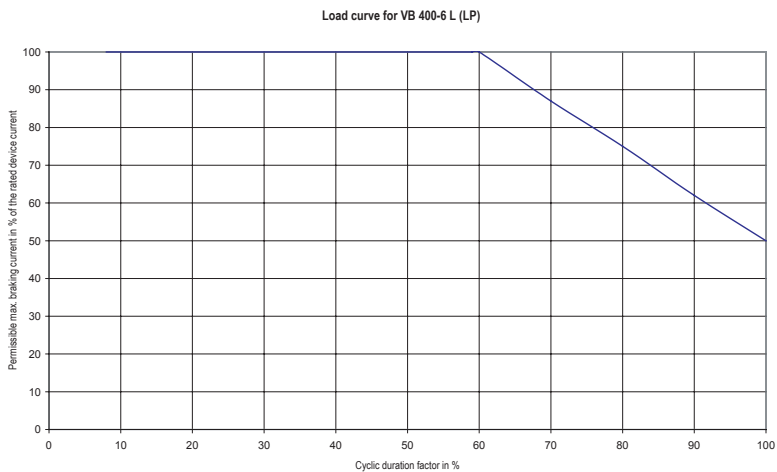

$$\text{Cyclic duration factor (r.c.d.f.)} = \frac{t_B}{\text{Cycle time}} \times 100$$

t_B = Braking time, Cycle time = Braking time + Non-braking time

Load curve for VB ...-25 L (LP)

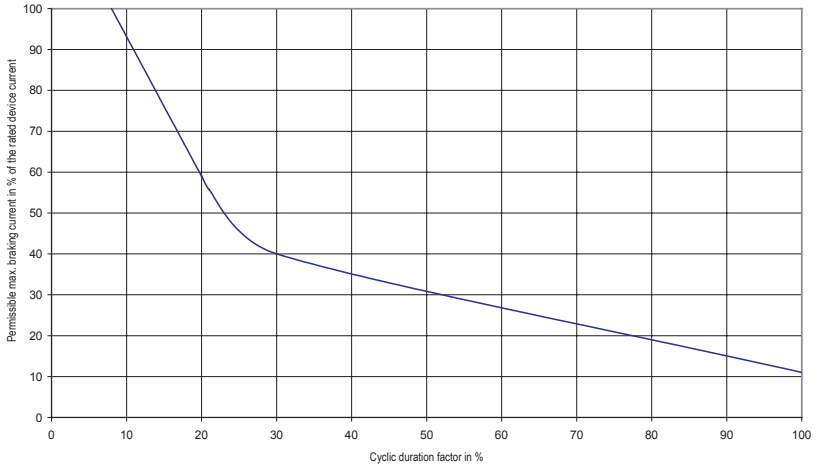

Load curve for BR 230/400-30L (LP)

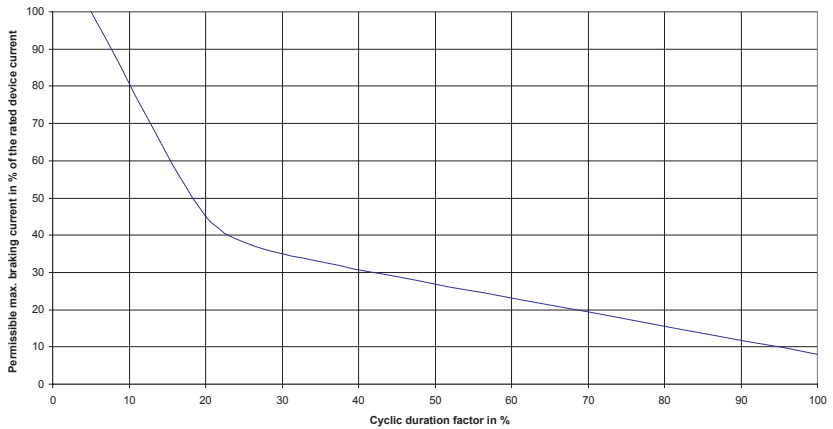

13. Dimensions

Enclosed version (with housing):

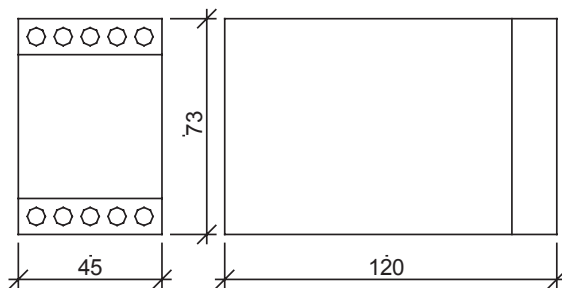

Printed circuit-board version:

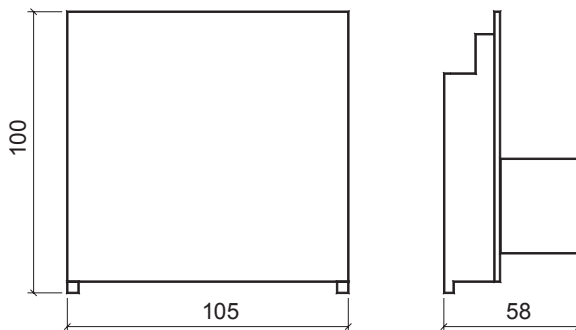

All dimensions indicated in mm.

14. Typical connections

14.1 Connection diagram

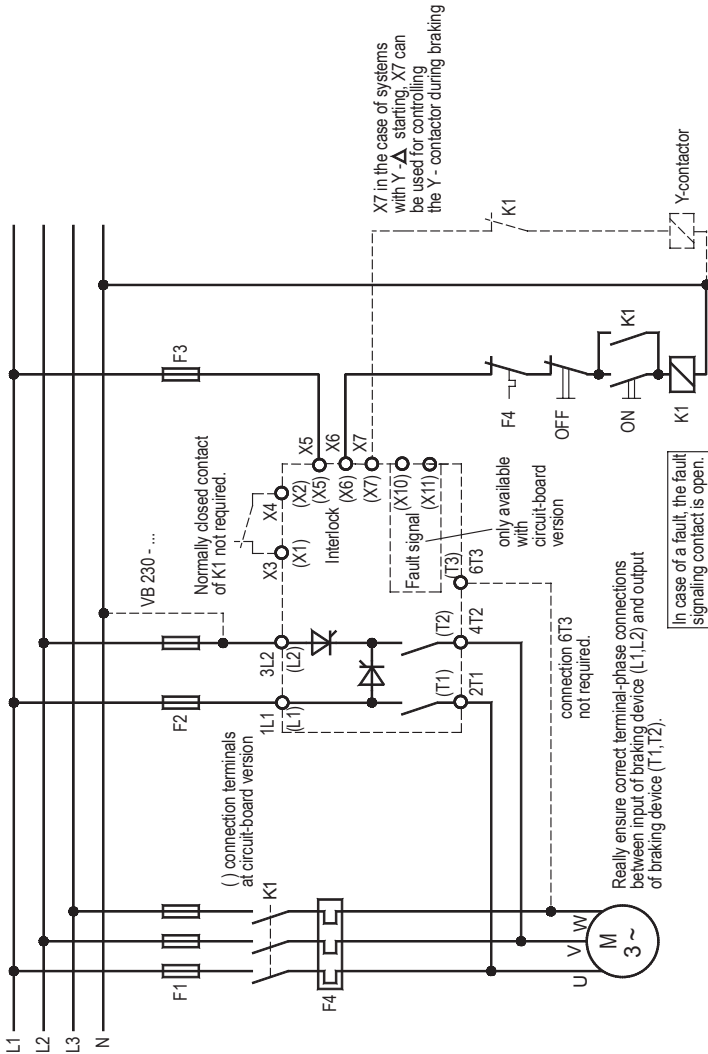

EMC

The limit values for emitted interference according to the applicable device standards do not rule out the possibility that receivers and susceptible electronic devices within a radius of 10m are subjected to interference. If such interference, which is definitely attributable to the operation of the braking devices "VB", occurs, the emitted interference can be reduced by taking appropriate measures.

Such measures are, e.g.:

To connect reactors (3mH) or a suitable mains filter in series before the braking device, or to connect X-capacitors (0.15µF) in parallel to the supply voltage terminals.



www.peter-electronic.com

