

Materials / Surfaces:

Input flange: Aluminum / untreated
 Angle housing: Aluminum / untreated
 Housing: Steel / heat-treated and post-oxidized (black)
 Output flange: Steel / untreated

Hints:

Please pay attention to the operating and mounting instructions.
 Subject to modifications.

Variables on the drawing are dependent upon the motor.
 The given dimensions are exemplary.

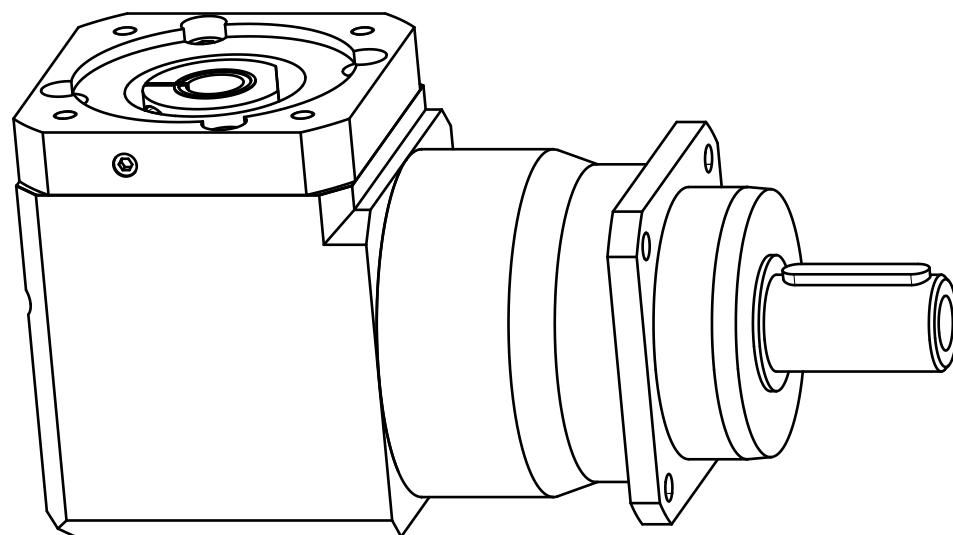
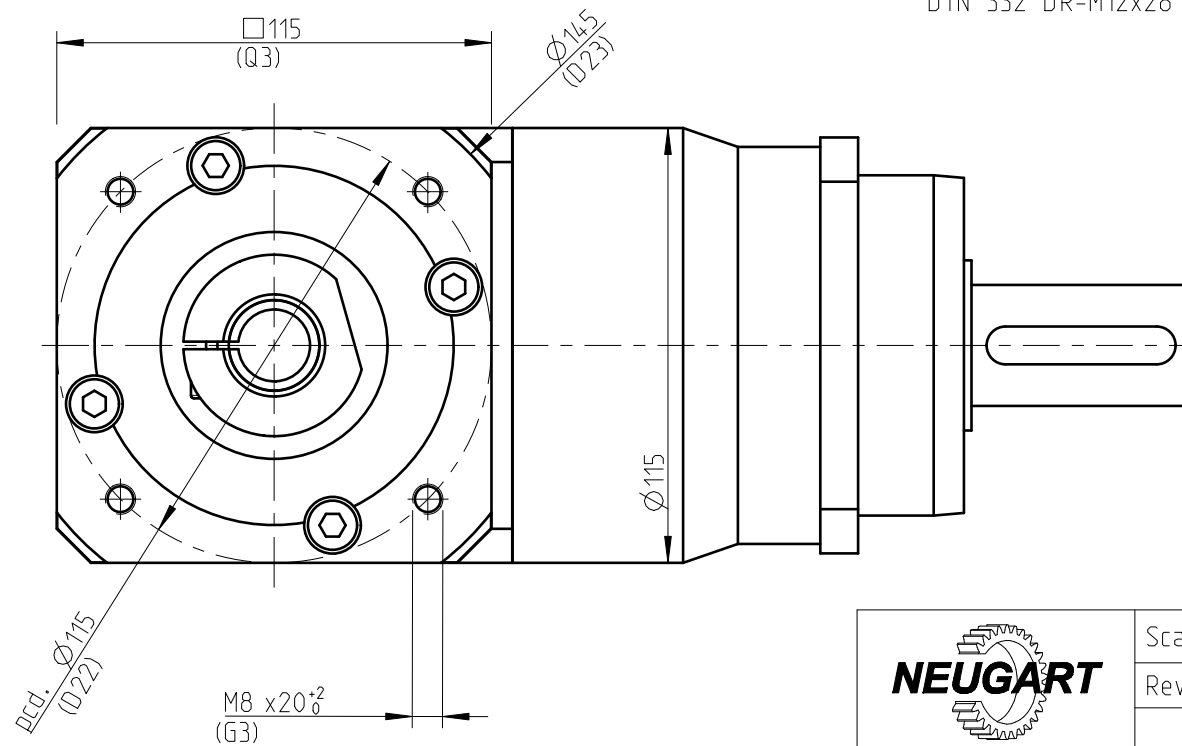

	Scale: 1:2	DIN A3	ISO
	Revision status: A from: 05/2022		
General tolerance DIN ISO 2768-cL	W PLHE120-bii-SSSA3AF-Y(D20) /(L20)/(D21)/(D22)/B5/(G3)		
Neugart GmbH Keltenstr. 16 D-77971 Kippenheim			Sheet 1/2

General gearbox data	Character	Unit	
Bevel gearbox - gearing type	-	-	Straight teeth
Rotation direction	-	-	Input and output in the same direction
Number of stages	p	-	2-stage
Output shaft bearing	-	-	Tapered roller bearing
Service Life (L10h)	t_L	h	20.000
Max. operating temperature	T_{min} / T_{max}	°C	-25 / +90
Protection class	-	-	IP 65
Right angle gearbox lubrication (lubricated for life)	-	-	Standard lubrication (Klüberplex BEM 34-132)
Planetary gearbox lubrication (lubricated for life)	-	-	Standard lubrication (Klübersynth GE 14-112)
Installation position	-	-	Any
Max. bending moment based on the gearbox input flange (for motor weight) (1)	M_b	Nm	26
Motor shaft concentricity / Coaxiality and axial runout Motor flange	-	mm	0,04 / 0,08 (Measuring methods according to DIN EN 50347)
Required motor shaft tolerance	-	-	j6; k6
Min. permissible motor shaft length	L_{20min}	mm	18
Reference operating mode	-	-	S1
Reference operating factor	K_A	-	1
Reference speed	n_2	rpm	100
Reference ambient temperature	T_{Amb}	°C	20
Radial force for output bearing based on shaft center after L10h=20,000h with Fa=0N	$F_{r 20.000h}$	N	6000
Axial force for output bearing based on gearbox axis after L10h=20,000h with Fr=0N	$F_{a 20.000h}$	N	8000
Radial force for output bearing based on shaft center after L10h=30,000h with Fa=0N	$F_{r 30.000h}$	N	5400
Axial force for output bearing based on gearbox axis after L10h=30,000h with Fr=0N	$F_{a 30.000h}$	N	7000
Maximum radial force based on shaft center and T2=0Nm	$F_{r Max}$	N	6000
Maximum axial force based on gearbox axis and T2=0Nm	$F_{a Max}$	N	8000

$$(1) \text{ Max. motor weight* in kg} = \frac{0,2 \times M_b}{\text{motor length in m}}$$

- * with symmetrically distributed motor weight
- * with horizontal and stationary mounting

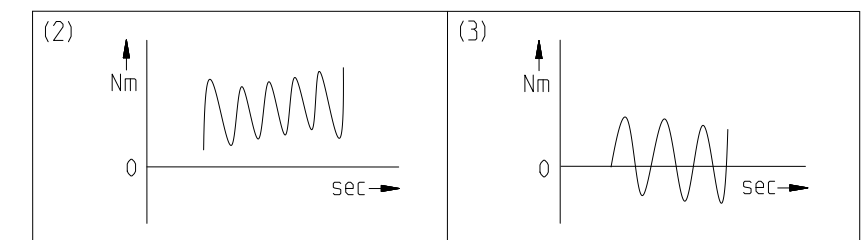

Ratio-dependent gearbox data	Character	Unit										
Ratio	bii	-	9	12	15	16	20	25	32	40	64	100
Nominal output torque No alternating torque (2)	T_{2N}	Nm	210 ⁽⁵⁾	260 ⁽⁵⁾	230	260	260	230	260	230	120	95
Nominal output torque Alternating torque permitted for 10,000,000 load changes (3)	$T_{2N 10Mio}$	Nm	210	239	230	239	239	230	239	230	120	95
Nominal output torque Alternating torque permitted for 100,000,000 load changes (3)	$T_{2N 100Mio}$	Nm	190	190	190	190	190	190	190	190	120	95
Max. output torque for 30,000 output shaft rotations (2)	T_{2max}	Nm	336	416	368	416	416	368	416	368	192	152
Emergency stop torque permitted 1000 times	T_{2Stop}	Nm	500	520	500	520	520	500	520	500	380	430
Average idle torque for n1=3,000 rpm and 20 °C gearbox temperature	T_0	Nm	1,4	1,35	1,3	1,3	1,15	1,1	0,95	0,95	0,9	0,9
Average thermal input speed at 50% T2N, S1, and T_Amb Operating temperature may not be exceeded!	$n_{1N 50\%}$	rpm	2500	2600	3000	3000	3400	3500	3500	3500	3500	3500
Average thermal input speed at 100% T2N, S1, and T_Amb Operating temperature may not be exceeded!	$n_{1N 100\%}$	rpm	1800	1900	2300	2250	2600	3050	3400	3500	3500	3500
Max. mechanical input speed Operating temperature may not be exceeded!	$n_{1 Limit}$	rpm	6500	6500	6500	6500	6500	6500	6500	6500	6500	6500
Torsional backlash based on output shaft	j_t	arcmin	< 13	< 13	< 13	< 13	< 13	< 13	< 13	< 13	< 13	< 13
Torsional stiffness based on output shaft	c_g	Nm/arcmin	21,5	24,5	24,5	25,5	25,5	25	26	25,5	21,5	16,7
Efficiency at T2N, gearbox temperature 70 °C and n1=1,000rpm	η	%	94	94	94	94	93	92	92	91	83	74
Running noise at n1=3,000 rpm without load at a distance of 1m	Q_g	dB(A)	75	75	75	75	75	75	75	75	75	75
Gearbox weight	m_G	kg	12,5	12,6	12,6	12,6	12,6	12,6	12,6	12,7	12,6	12,8
Mass moment of inertia based on clamping system diameter input	J	kgcm ²	3,611	3,541	3,517	3,017	2,842	2,833	2,687	2,683	2,679	2,643

(5) Different Lifetime: 10,000h at T2N



WPLHE120-bii-SSSA3AF-Y(D20)
/(L20)/(D21)/(D22)/B5/(G3)

Sheet 2/2

Subject to modifications.

Revision status: A from: 05/2022