

Materials / Surfaces:

Input flange: Aluminum / untreated
 Angle housing: Aluminum / untreated
 Housing: Steel / heat-treated and post-oxidized (black)
 Output flange: Steel / untreated

Hints:

Please pay attention to the operating and mounting instructions.
 Subject to modifications.

Variables on the drawing are dependent upon the motor.
 The given dimensions are exemplary.

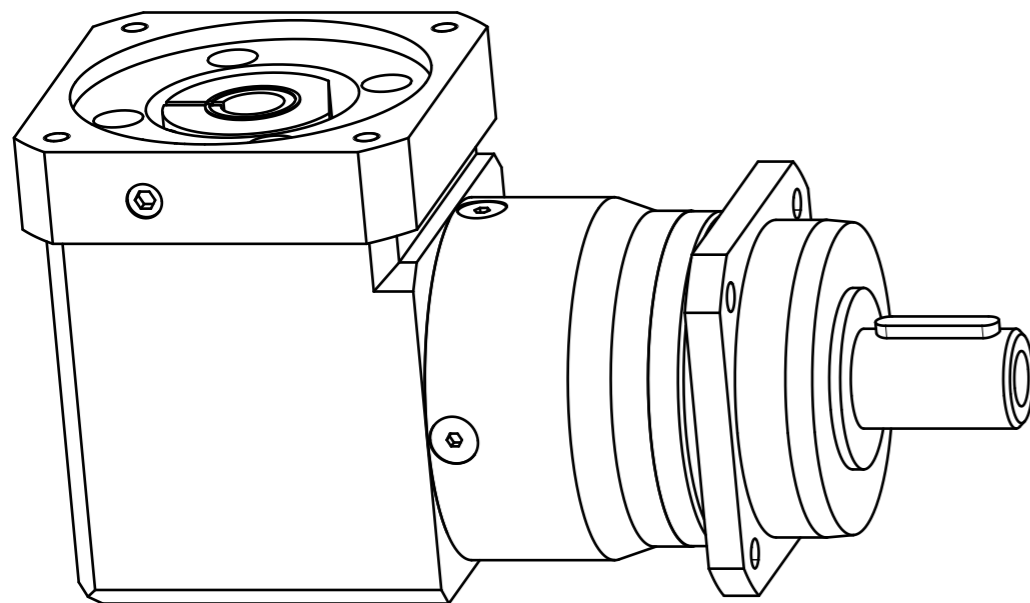

	Scale: 7:10	DIN A3	ISO
	Revision status: A from: 05/2022		
General tolerance DIN ISO 2768-cL	W PLHE080-aii-SSSA3AE-Y(D20) /(L20)/(D21)/(D22)/B5/(G3)		
Neugart GmbH Keltenstr. 16 D-77971 Kippenheim			Sheet 1/2

General gearbox data	Character	Unit	
Bevel gearbox - gearing type	-	-	Straight teeth
Rotation direction	-	-	Input and output in the same direction
Number of stages	p	-	1-stage
Output shaft bearing	-	-	Tapered roller bearing
Service Life (L10h)	t_L	h	20.000
Max. operating temperature	T_{min} / T_{max}	°C	-25 / +90
Protection class	-	-	IP 65
Right angle gearbox lubrication (lubricated for life)	-	-	Standard lubrication (Klüberplex BEM 34-132)
Planetary gearbox lubrication (lubricated for life)	-	-	Standard lubrication (Klübersynth GE 14-112)
Installation position	-	-	Any
Max. bending moment based on the gearbox input flange (for motor weight) (1)	M_b	Nm	10,5
Motor shaft concentricity / Coaxiality and axial runout Motor flange	-	mm	0,04 / 0,08 (Measuring methods according to DIN EN 50347)
Required motor shaft tolerance	-	-	j6; k6
Min. permissible motor shaft length	L_{20min}	mm	19
Reference operating mode	-	-	S1
Reference operating factor	K_A	-	1
Reference speed	n_2	rpm	100
Reference ambient temperature	T_{Amb}	°C	20
Radial force for output bearing based on shaft center after L10h=20,000h with Fa=0N	$F_r 20.000h$	N	5500
Axial force for output bearing based on gearbox axis after L10h=20,000h with Fr=0N	$F_a 20.000h$	N	6400
Radial force for output bearing based on shaft center after L10h=30,000h with Fa=0N	$F_r 30.000h$	N	4800
Axial force for output bearing based on gearbox axis after L10h=30,000h with Fr=0N	$F_a 30.000h$	N	5700
Maximum radial force based on shaft center and T2=0Nm	$F_r Max$	N	5500
Maximum axial force based on gearbox axis and T2=0Nm	$F_a Max$	N	6400

$$(1) \text{ Max. motor weight* in kg} = \frac{0,2 \times M_b}{\text{motor length in m}}$$

- * with symmetrically distributed motor weight
- * with horizontal and stationary mounting

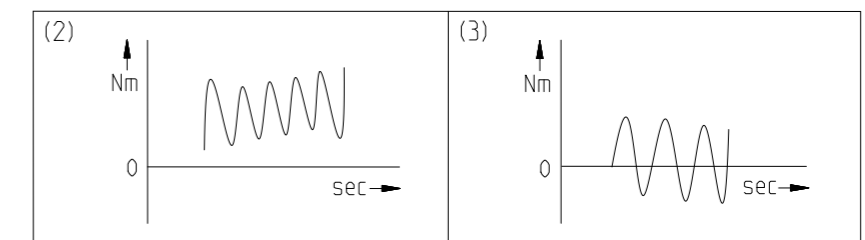

Ratio-dependent gearbox data	Character	Unit							
Ratio	aii	-	3	4	5	7	8	10	
Nominal output torque No alternating torque (2)	T_{2N}	Nm	40 ⁽⁵⁾	53 ⁽⁵⁾	67 ⁽⁵⁾	65	50	38	
Nominal output torque Alternating torque permitted for 10,000,000 load changes (3)	$T_{2N 10Mio}$	Nm	40	53	67	65	50	38	
Nominal output torque Alternating torque permitted for 100,000,000 load changes (3)	$T_{2N 100Mio}$	Nm	40	53	60	60	50	38	
Max. output torque for 30,000 output shaft rotations (2)	T_{2max}	Nm	64	85	107	104	80	61	
Emergency stop torque permitted 1000 times	T_{2Stop}	Nm	180	240	220	178	190	170	
Average idle torque for n1=3,000 rpm and 20 °C gearbox temperature	T_0	Nm	1,2	1	0,85	0,7	0,65	0,6	
Average thermal input speed at 50% T2N, S1, and T_Amb Operating temperature may not be exceeded!	$n_{1N 50\%}$	rpm	2050	2300	2450	3100	3550	4000	
Average thermal input speed at 100% T2N, S1, and T_Amb Operating temperature may not be exceeded!	$n_{1N 100\%}$	rpm	1650	1750	1850	2400	2900	3600	
Max. mechanical input speed Operating temperature may not be exceeded!	$n_1 Limit$	rpm	7000	7000	7000	7000	7000	7000	
Torsional backlash based on output shaft	j_t	arcmin	< 13	< 13	< 13	< 13	< 13	< 13	
Torsional stiffness based on output shaft	c_g	Nm/arcmin	4,3	6,5	7,7	8,3	8,4	8,7	
Efficiency at T2N, gearbox temperature 70 °C and n1=1,000rpm	η	%	93	93	94	93	92	90	
Running noise at n1=3,000 rpm without load at a distance of 1m	Q_g	dB(A)	73	73	73	73	73	73	
Gearbox weight	m_G	kg	4,6	4,6	4,6	4,6	4,6	4,6	
Mass moment of inertia based on clamping system diameter input	J	kgcm ²	1,346	1,041	0,968	0,903	0,89	0,873	

(5) Different Lifetime: 10,000h at T2N



W PLHE080-aii-SSSA3AE-Y(D20)
/(L20)/(D21)/(D22)/B5/(G3)

Sheet 2/2

Subject to modifications.

Revision status: A from: 05/2022