

Flange output shaft with dowel hole (ISO 9409-1)

Materials / Surfaces:

Input flange: Aluminum / untreated
 Angle housing: Aluminum / untreated
 Housing: Steel / heat-treated and post-oxidized (black)
 Output flange: Steel / untreated

Hints:

Please pay attention to the operating and mounting instructions.
 Subject to modifications.

Variables on the drawing are dependent upon the motor.
 The given dimensions are exemplary.

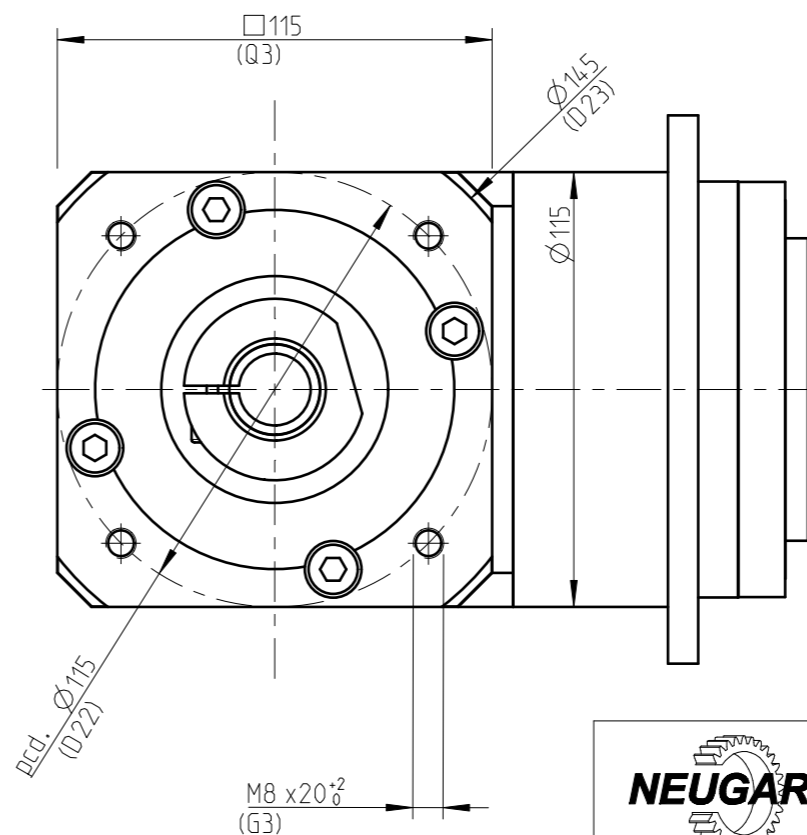
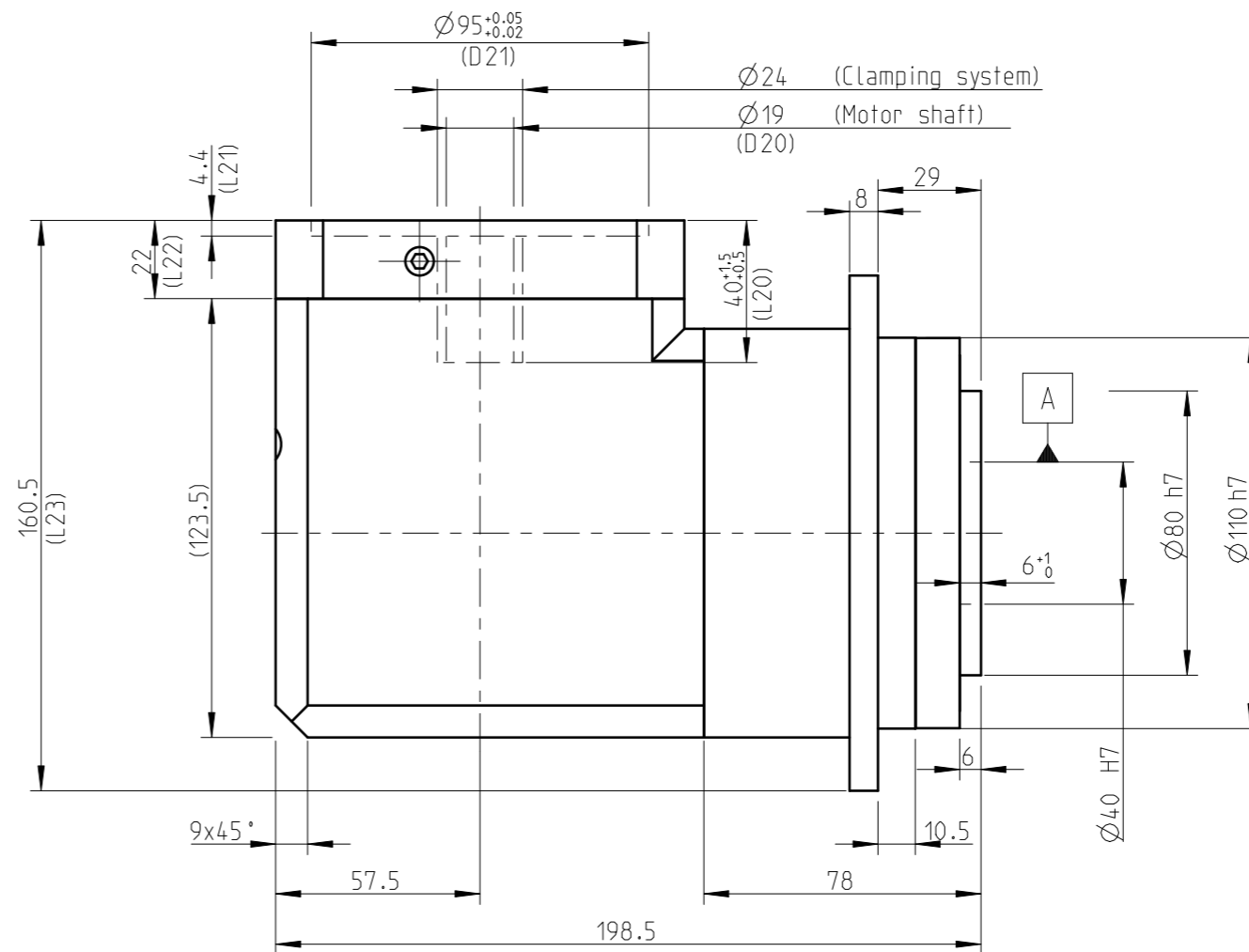
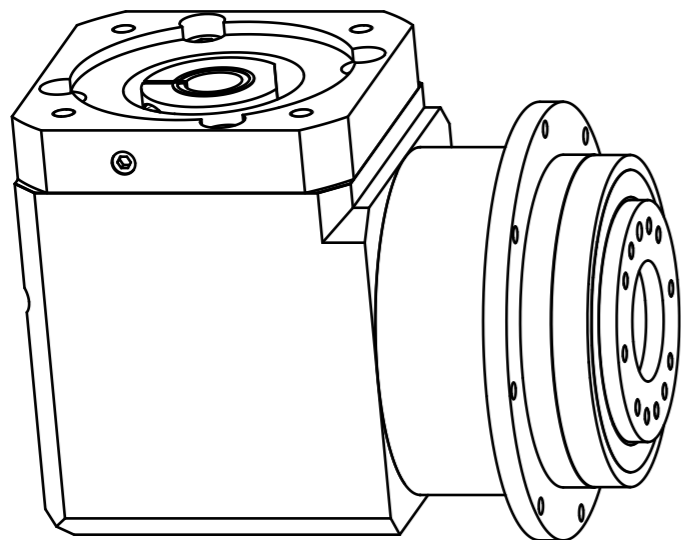

	Scale: 1:2	DIN A3	ISO
	Revision status: F from: 01/2023		
Changed revision status: E from: 09/2022			
General tolerance DIN ISO 2768-cl	WPLFE110-aii-SSSE3AF-Y(D20) /(L20)/(D21)/(D22)/B5/(G3)		
Neugart GmbH Keltenstr. 16 D-77971 Kippenheim			Sheet 1/2

General gearbox data	Character	Unit	
Bevel gearbox - gearing type	-	-	Straight teeth
Rotation direction	-	-	Input and output in the same direction
Number of stages	p	-	1-stage
Output shaft bearing	-	-	Deep groove ball bearing
Service life (L10h)	t _L	h	20.000
Max. operating temperature	T _{min} / T _{max}	°C	-25 / +90
Protection class	-	-	IP 54
Right angle gearbox lubrication (lubricated for life)	-	-	Standard lubrication (KLüberplex BEM 34-132)
Planetary gearbox lubrication (lubricated for life)	-	-	Standard lubrication (KLübersynth GE 14-112)
Installation position	-	-	Any
Max. bending moment based on the gearbox input flange (for motor weight) (1)	M _b	Nm	26
Motor shaft concentricity / Coaxiality and axial runout Motor flange	-	mm	0,04 / 0,08 (Measuring methods according to DIN EN 50347)
Required motor shaft tolerance	-	-	j6; k6
Min. permissible motor shaft length	L _{20 min}	mm	18
Reference operating mode	-	-	S1
Reference operating factor	K _A	-	1
Reference speed	n ₂	rpm	100
Reference ambient temperature	T _{Amb}	°C	20
Radial force for output bearing based on shaft end after L10h=20,000h with Fa=0N	F _{r 20.000h}	N	2400
Axial force for output bearing based on gearbox axis after L10h=20,000h with Fr=0N	F _{a 20.000h}	N	3300
Radial force for output bearing based on shaft end after L10h=30,000h with Fa=0N	F _{r 30.000h}	N	2100
Axial force for output bearing based on gearbox axis after L10h=30,000h with Fr=0N	F _{a 30.000h}	N	3300
Maximum radial force based on shaft end and T2=0Nm	F _{r Max}	N	3800
Maximum axial force based on gearbox axis and T2=0Nm	F _{a Max}	N	5200

$$(1) \text{ Max. motor weight* in kg} = \frac{0,2 \times M_b}{\text{motor length in m}}$$

- * with symmetrically distributed motor weight
- * with horizontal and stationary mounting

Ratio-dependent gearbox data	Character	Unit						
Ratio	aii	-	3	4	5	7	8	10
Nominal output torque	T _{2N}	Nm	80 ⁽⁵⁾	105 ⁽⁵⁾	130 ⁽⁵⁾	135	120	95
Max. output torque for 30.000 output shaft rotations	T _{2max}	Nm	128	168	208	216	192	152
Emergency stop torque permitted 1000 times	T _{2Stop}	Nm	360	474	500	340	380	430
Average idle torque for n1=3.000 rpm and 20 °C gearbox temperature	T ₀	Nm	2,3	1,8	1,55	1,25	1,2	1,1
Average thermal input speed at 50% T2N, S1, and T_Amb Operating temperature may not be exceeded!	n _{1N 50%}	rpm	2200	2400	2600	3000	3300	3500
Average thermal input speed at 100% T2N, S1, and T_Amb Operating temperature may not be exceeded!	n _{1N 100%}	rpm	1700	1800	1900	2200	2600	3200
Max. mechanical input speed Operating temperature may not be exceeded!	n _{1 Limit}	rpm	6500	6500	6500	6500	6500	6500
Torsional backlash based on output shaft	j _t	arcmin	< 11	< 11	< 11	< 11	< 11	< 11
Torsional stiffness based on output shaft	c _g	Nm/arcmin	15,9	26	34	40	40,5	36
Efficiency at T2N, gearbox temperature 70 °C and n1=1.000rpm	η	%	94	94	94	94	94	93
Running noise at n1=3.000 rpm without load at a distance of 1m	Q _g	dB(A)	75	75	75	75	75	75
Gearbox weight	m _G	kg	10,5	10,5	10,5	10,5	10,5	10,6
Mass moment of inertia based on clamping system diameter input	J	kgcm ²	4,739	3,694	3,282	2,926	2,847	2,751

(5) Different Lifetime: 10,000h at T2N

Subject to modifications.



WPLFE110-aii-SSSE3AF-Y(D20)
/(L20)/(D21)/(D22)/B5/(G3)

Sheet 2/2

Revision status: F from: 01/2023