

Materials / Surfaces:

Input flange: Aluminum / untreated
 Angle housing: Aluminum / untreated
 Housing: Steel / heat-treated and post-oxidized (black)
 Output flange: Aluminum / untreated

Hints:

Please pay attention to the operating and mounting instructions.
 Subject to modifications.

Variables on the drawing are dependent upon the motor.
 The given dimensions are exemplary.

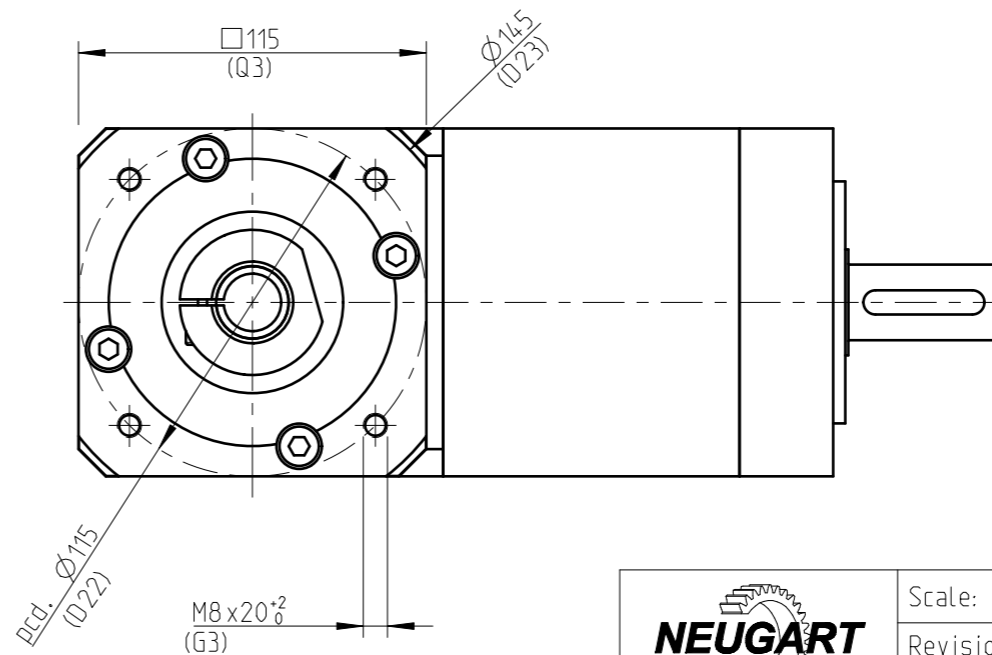
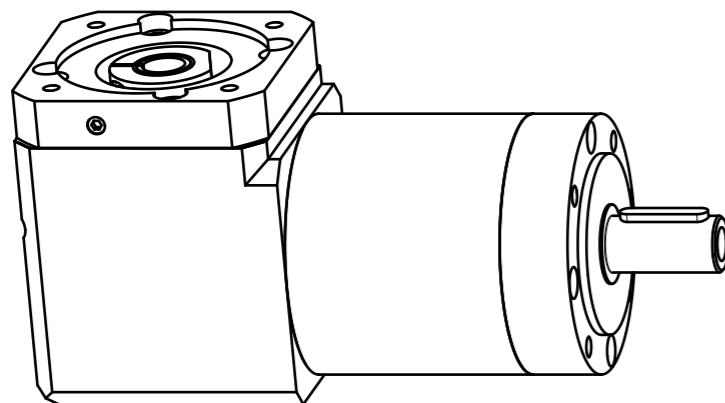

	Scale: 2:5	DIN A3	ISO
	Revision status: H from: 08/2022		
Changed revision status: G from: 01/2022			
General tolerance DIN ISO 2768-cL	WPLE120-cii-SSSA3AF-Y(D20) /(L20)/(D21)/(D22)/B5/(G3)		
Neugart GmbH Keltenstr. 16 D-77971 Kippenheim			Sheet 1/2

General gearbox data	Character	Unit	
Bevel gearbox - gearing type	-	-	Straight teeth
Rotation direction	-	-	Input and output in the same direction
Number of stages	p	-	3-stage
Output shaft bearing	-	-	Deep groove ball bearing
Service life (L10h)	t _L	h	20.000
Max. operating temperature	T _{min} / T _{max}	°C	-25 / +90
Protection class	-	-	IP 54
Right angle gearbox lubrication (lubricated for life)	-	-	Standard lubrication (KLüberplex BEM 34-132)
Planetary gearbox lubrication (lubricated for life)	-	-	Standard lubrication (KLübersynth GE 14-112)
Installation position	-	-	Any
Max. bending moment based on the gearbox input flange (for motor weight) (1)	M _b	Nm	26
Motor shaft concentricity / Coaxiality and axial runout Motor flange	-	mm	0,04 / 0,08 (Measuring methods according to DIN EN 50347)
Required motor shaft tolerance	-	-	j6; k6
Min. permissible motor shaft length	L _{20 min}	mm	18
Reference operating mode	-	-	S1
Reference operating factor	K _A	-	1
Reference speed	n ₂	rpm	100
Reference ambient temperature	T _{Amb}	°C	20
Radial force for output bearing based on shaft center after L10h=20,000h with Fa=0N	F _{r 20.000h}	N	1750
Axial force for output bearing based on gearbox axis after L10h=20,000h with Fr=0N	F _{a 20.000h}	N	2500
Radial force for output bearing based on shaft center after L10h=30,000h with Fa=0N	F _{r 30.000h}	N	1500
Axial force for output bearing based on gearbox axis after L10h=30,000h with Fr=0N	F _{a 30.000h}	N	2100
Maximum radial force based on shaft center and T2=0Nm	F _{r Max}	N	2000
Maximum axial force based on gearbox axis and T2=0Nm	F _{a Max}	N	3800

Ratio-dependent gearbox data	Character	Unit									
Ratio	cii	-	60	80	100	120	160	200	256	320	512
Nominal output torque No alternating torque (2)	T _{2N}	Nm	260	260	260	230	260	230	260	230	120
Nominal output torque Alternating torque permitted for 10,000,000 load changes (3)	T _{2N 10Mio}	Nm	132	132	132	132	132	132	132	132	120
Nominal output torque Alternating torque permitted for 100,000,000 load changes (3)	T _{2N 100Mio}	Nm	105	105	105	105	105	105	105	105	105
Max. output torque for 30,000 output shaft rotations (2)	T _{2max}	Nm	416	416	416	368	416	368	416	368	192
Emergency stop torque permitted 1000 times	T _{2Stop}	Nm	520	520	520	500	520	500	520	500	380
Average idle torque for n1=3,000 rpm and 20 °C gearbox temperature	T ₀	Nm	1,05	1	1	0,85	0,85	0,85	0,85	0,85	0,85
Average thermal input speed at 50% T2N, S1, and T_Amb Operating temperature may not be exceeded!	n _{1N 50%}	rpm	3500	3500	3500	3500	3500	3500	3500	3500	3500
Average thermal input speed at 100% T2N, S1, and T_Amb Operating temperature may not be exceeded!	n _{1N 100%}	rpm	3500	3500	3500	3500	3500	3500	3500	3500	3500
Max. mechanical input speed Operating temperature may not be exceeded!	n _{1 Limit}	rpm	6500	6500	6500	6500	6500	6500	6500	6500	6500
Torsional backlash based on output shaft	j _t	arcmin	< 15	< 15	< 15	< 15	< 15	< 15	< 15	< 15	< 15
Torsional stiffness based on output shaft	c _g	Nm/arcmin	20,5	20,5	20,5	20	20,5	20	20,5	20	17,5
Efficiency at T2N, gearbox temperature 70 °C and n1=1,000rpm	η	%	88	87	85	82	81	77	75	70	46
Running noise at n1=3,000 rpm without load at a distance of 1m	Q _g	dB(A)	75	75	75	75	75	75	75	75	75
Gearbox weight	m _G	kg	13,2	13,2	13,2	13,3	13,3	13,4	13,3	13,4	13,4
Mass moment of inertia based on clamping system diameter input	J	kgcm ²	3,506	2,836	2,83	3,488	2,682	2,682	2,679	2,679	2,679

$$(1) \text{ Max. motor weight* in kg} = \frac{0,2 \times M_b}{\text{motor length in m}}$$

- * with symmetrically distributed motor weight
- * with horizontal and stationary mounting

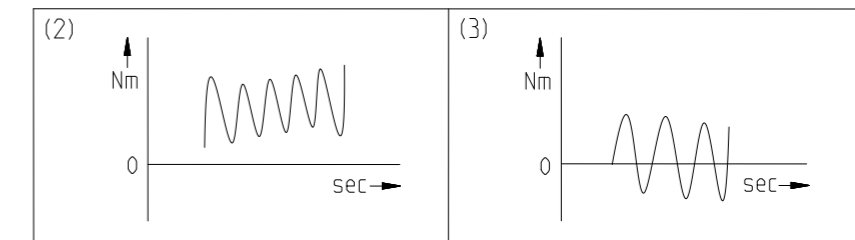

Subject to modifications.



WPLE120-cii-SSSA3AF-Y(D20)
/(L20)/(D21)/(D22)/B5/(G3)

Sheet 2/2

Revision status: H from: 08/2022