

**Materials / Surfaces:**

Input flange: Aluminum / untreated  
 Angle housing: Aluminum / untreated  
 Housing: Steel / heat-treated and post-oxidized (black)  
 Output flange: Aluminum / untreated

**Hints:**

Please pay attention to the operating and mounting instructions.  
 Subject to modifications.

Variables on the drawing are dependent upon the motor.  
 The given dimensions are exemplary.

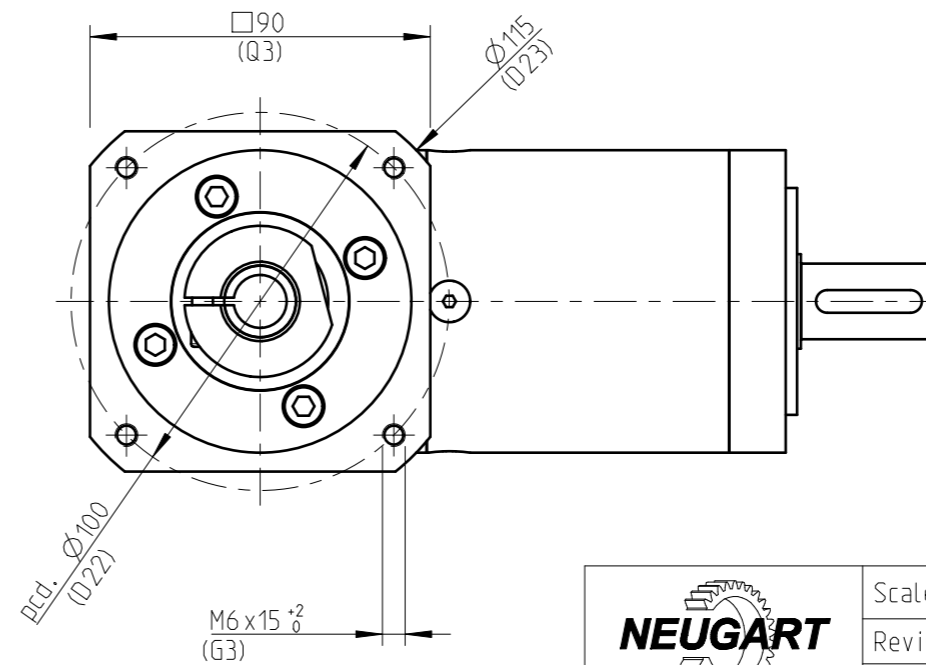
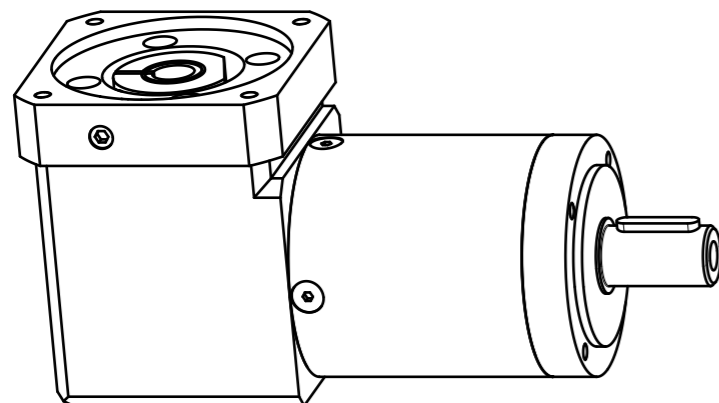

	Scale: 1:2	DIN A3	ISO
	Revision status: H from: 08/2022		
Changed revision status: G from: 01/2022			
General tolerance DIN ISO 2768-cL	WPLE080-cii-SSSA3AE-Y(D20) /(L20)/(D21)/(D22)/B5/(G3)		
Neugart GmbH Keltenstr. 16 D-77971 Kippenheim			Sheet 1/2

General gearbox data	Character	Unit	
Bevel gearbox - gearing type	-	-	Straight teeth
Rotation direction	-	-	Input and output in the same direction
Number of stages	p	-	3-stage
Output shaft bearing	-	-	Deep groove ball bearing
Service life (L10h)	$t_L$	h	20.000
Max. operating temperature	$T_{min} / T_{max}$	°C	-25 / +90
Protection class	-	-	IP 54
Right angle gearbox lubrication (lubricated for life)	-	-	Standard lubrication (KLüberplex BEM 34-132)
Planetary gearbox lubrication (lubricated for life)	-	-	Standard lubrication (KLübersynth GE 14-112)
Installation position	-	-	Any
Max. bending moment based on the gearbox input flange (for motor weight) (1)	$M_b$	Nm	10,5
Motor shaft concentricity / Coaxiality and axial runout Motor flange	-	mm	0,04 / 0,08 (Measuring methods according to DIN EN 50347)
Required motor shaft tolerance	-	-	j6; k6
Min. permissible motor shaft length	$L_{20 min}$	mm	19
Reference operating mode	-	-	S1
Reference operating factor	$K_A$	-	1
Reference speed	$n_2$	rpm	100
Reference ambient temperature	$T_{Amb}$	°C	20
Radial force for output bearing based on shaft center after L10h=20,000h with Fa=0N	$F_r 20.000h$	N	750
Axial force for output bearing based on gearbox axis after L10h=20,000h with Fr=0N	$F_a 20.000h$	N	1000
Radial force for output bearing based on shaft center after L10h=30,000h with Fa=0N	$F_r 30.000h$	N	650
Axial force for output bearing based on gearbox axis after L10h=30,000h with Fr=0N	$F_a 30.000h$	N	900
Maximum radial force based on shaft center and T2=0Nm	$F_r Max$	N	1250
Maximum axial force based on gearbox axis and T2=0Nm	$F_a Max$	N	1600

Ratio-dependent gearbox data	Character	Unit									
Ratio	cii	-	60	80	100	120	160	200	256	320	512
Nominal output torque No alternating torque (2)	$T_{2N}$	Nm	110	120	120	110	120	110	120	110	50
Nominal output torque Alternating torque permitted for 10,000,000 load changes (3)	$T_{2N 10Mio}$	Nm	68	68	68	68	68	68	68	68	50
Nominal output torque Alternating torque permitted for 100,000,000 load changes (3)	$T_{2N 100Mio}$	Nm	54	54	54	54	54	54	54	54	50
Max. output torque for 30,000 output shaft rotations (2)	$T_{2max}$	Nm	176	192	192	176	192	176	192	176	80
Emergency stop torque permitted 1000 times	$T_{2stop}$	Nm	220	240	240	220	240	220	240	220	190
Average idle torque for $n_1=3,000$ rpm and 20 °C gearbox temperature	$T_0$	Nm	0,35	0,35	0,35	0,35	0,25	0,25	0,25	0,25	0,25
Average thermal input speed at 50% T2N, S1, and T_Amb Operating temperature may not be exceeded!	$n_{1N 50\%}$	rpm	4000	4000	4000	4000	4000	4000	4000	4000	4000
Average thermal input speed at 100% T2N, S1, and T_Amb Operating temperature may not be exceeded!	$n_{1N 100\%}$	rpm	4000	4000	4000	4000	4000	4000	4000	4000	4000
Max. mechanical input speed Operating temperature may not be exceeded!	$n_{1 Limit}$	rpm	7000	7000	7000	7000	7000	7000	7000	7000	7000
Torsional backlash based on output shaft	$j_t$	arcmin	< 17	< 17	< 17	< 17	< 17	< 17	< 17	< 17	< 17
Torsional stiffness based on output shaft	$c_g$	Nm/arcmin	9,7	9,8	9,8	9,6	9,8	9,7	9,7	9,6	7,9
Efficiency at T2N, gearbox temperature 70 °C and $n_1=1,000$ rpm	$\eta$	%	87	86	84	81	79	74	72	66	38
Running noise at $n_1=3,000$ rpm without load at a distance of 1m	$Q_g$	dB(A)	73	73	73	73	73	73	73	73	73
Gearbox weight	$m_G$	kg	4,6	4,6	4,7	4,7	4,7	4,7	4,7	4,7	4,7
Mass moment of inertia based on clamping system diameter input	J	kgcm <sup>2</sup>	1,156	0,907	0,906	1,162	0,868	0,868	0,869	0,869	0,869

$$(1) \text{ Max. motor weight* in kg} = \frac{0,2 \times M_b}{\text{motor length in m}}$$

- \* with symmetrically distributed motor weight
- \* with horizontal and stationary mounting

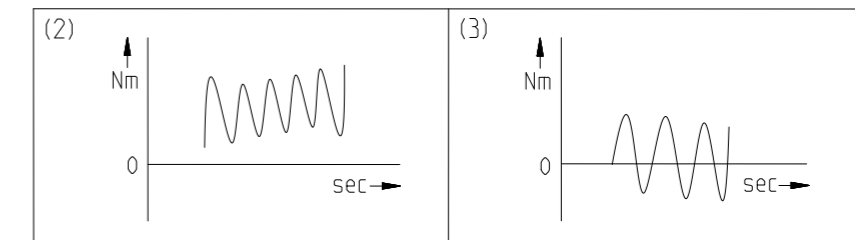

Subject to modifications.



WPLE080-cii-SSSA3AE-Y(D20)  
/(L20)/(D21)/(D22)/B5/(G3)

Sheet 2/2

Revision status: H from: 08/2022