

Materials / Surfaces:

Input flange: Aluminum / untreated
 Angle housing: Aluminum / untreated
 Housing: Steel / heat-treated and post-oxidized (black)
 Output flange: Aluminum / untreated

Hints:

Please pay attention to the operating and mounting instructions.
 Subject to modifications.

Variables on the drawing are dependent upon the motor.
 The given dimensions are exemplary.

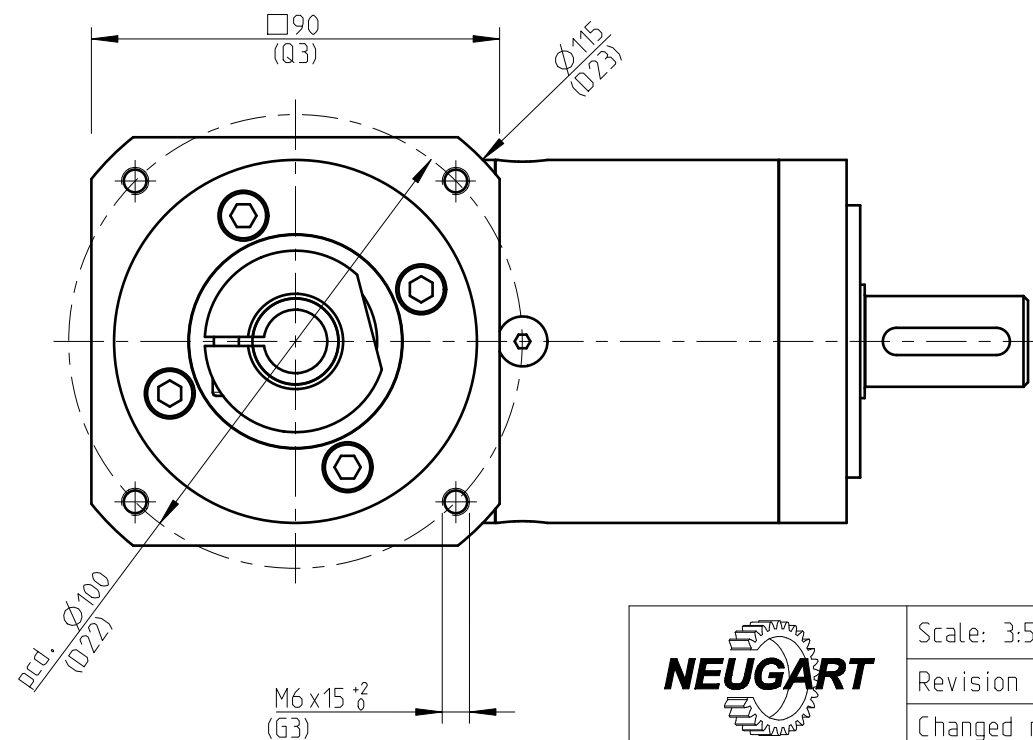
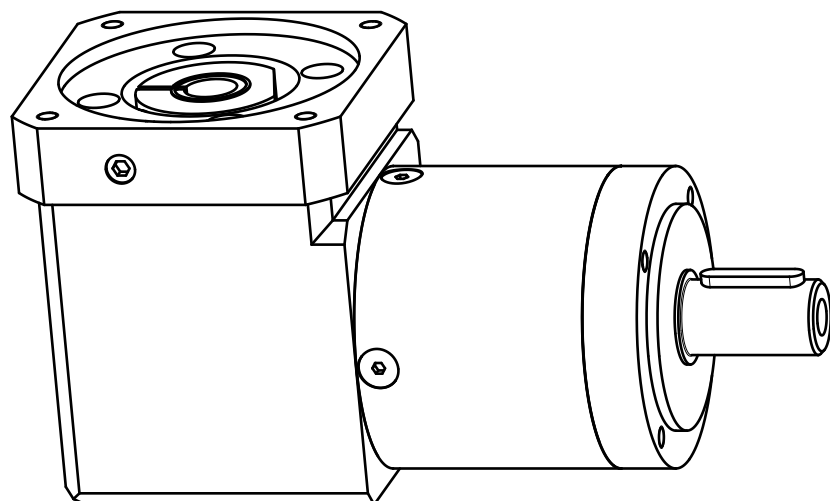

| | | | |
|---|---|--------|-----------|
|  | Scale: 3:5 | DIN A3 | ISO |
| | Revision status: H from: 08/2022 | | |
| Changed revision status: G from: 01/2022 | | | |
| General tolerance DIN ISO 2768-cL | W PLE080-bii-SSSA3AE-Y(D20) /(L20)/(D21)/(D22)/B5/(G3) | | |
| Neugart GmbH Keltenstr. 16 D-77971 Kippenheim | | | Sheet 1/2 |

| General gearbox data | Character | Unit | |
|---|---------------------|------|---|
| Bevel gearbox - gearing type | - | - | Straight teeth |
| Rotation direction | - | - | Input and output in the same direction |
| Number of stages | p | - | 2-stage |
| Output shaft bearing | - | - | Deep groove ball bearing |
| Service life (L10h) | t_L | h | 20.000 |
| Max. operating temperature | T_{min} / T_{max} | °C | -25 / +90 |
| Protection class | - | - | IP 54 |
| Right angle gearbox lubrication (lubricated for life) | - | - | Standard lubrication (KLüberplex BEM 34-132) |
| Planetary gearbox lubrication (lubricated for life) | - | - | Standard lubrication (KLübersynth GE 14-112) |
| Installation position | - | - | Any |
| Max. bending moment based on the gearbox input flange (for motor weight) (1) | M_b | Nm | 10,5 |
| Motor shaft concentricity / Coaxiality and axial runout Motor flange | - | mm | 0,04 / 0,08 (Measuring methods according to DIN EN 50347) |
| Required motor shaft tolerance | - | - | j6; k6 |
| Min. permissible motor shaft length | $L_{20 min}$ | mm | 19 |
| Reference operating mode | - | - | S1 |
| Reference operating factor | K_A | - | 1 |
| Reference speed | n_2 | rpm | 100 |
| Reference ambient temperature | T_{Amb} | °C | 20 |
| Radial force for output bearing based on shaft center after L10h=20,000h with Fa=0N | $F_r 20.000h$ | N | 750 |
| Axial force for output bearing based on gearbox axis after L10h=20,000h with Fr=0N | $F_a 20.000h$ | N | 1000 |
| Radial force for output bearing based on shaft center after L10h=30,000h with Fa=0N | $F_r 30.000h$ | N | 650 |
| Axial force for output bearing based on gearbox axis after L10h=30,000h with Fr=0N | $F_a 30.000h$ | N | 900 |
| Maximum radial force based on shaft center and T2=0Nm | $F_r Max$ | N | 1250 |
| Maximum axial force based on gearbox axis and T2=0Nm | $F_a Max$ | N | 1600 |

| Ratio-dependent gearbox data | Character | Unit | | | | | | | | | |
|--|-----------------|-------------------|--------------------|--------------------|-------|-------|-------|-------|-------|-------|-------|
| Ratio | bii | - | 9 | 12 | 15 | 16 | 20 | 25 | 32 | 40 | 64 |
| Nominal output torque No alternating torque (2) | T_{2N} | Nm | 130 ⁽⁵⁾ | 120 ⁽⁵⁾ | 110 | 120 | 120 | 110 | 120 | 110 | 50 |
| Nominal output torque Alternating torque permitted for 10,000,000 load changes (3) | $T_{2N 10Mio}$ | Nm | 68 | 68 | 68 | 68 | 68 | 68 | 68 | 68 | 50 |
| Nominal output torque Alternating torque permitted for 100,000,000 load changes (3) | $T_{2N 100Mio}$ | Nm | 54 | 54 | 54 | 54 | 54 | 54 | 54 | 54 | 50 |
| Max. output torque for 30,000 output shaft rotations (2) | T_{2max} | Nm | 208 | 192 | 176 | 192 | 192 | 176 | 192 | 176 | 80 |
| Emergency stop torque permitted 1000 times | T_{2stop} | Nm | 260 | 240 | 220 | 240 | 240 | 220 | 240 | 220 | 190 |
| Average idle torque for n1=3,000 rpm and 20 °C gearbox temperature | T_0 | Nm | 0,6 | 0,55 | 0,35 | 0,45 | 0,35 | 0,35 | 0,25 | 0,25 | 0,25 |
| Average thermal input speed at 50% T2N, S1, and T_Amb Operating temperature may not be exceeded! | $n_{1N 50\%}$ | rpm | 3250 | 3850 | 4000 | 4000 | 4000 | 4000 | 4000 | 4000 | 4000 |
| Average thermal input speed at 100% T2N, S1, and T_Amb Operating temperature may not be exceeded! | $n_{1N 100\%}$ | rpm | 2100 | 2650 | 3150 | 3100 | 3550 | 4000 | 4000 | 4000 | 4000 |
| Max. mechanical input speed Operating temperature may not be exceeded! | $n_{1 Limit}$ | rpm | 7000 | 7000 | 7000 | 7000 | 7000 | 7000 | 7000 | 7000 | 7000 |
| Torsional backlash based on output shaft | j_t | arcmin | < 15 | < 15 | < 15 | < 15 | < 15 | < 15 | < 15 | < 15 | < 15 |
| Torsional stiffness based on output shaft | c_g | Nm/arcmin | 7,2 | 9 | 9,2 | 9,4 | 9,5 | 9,5 | 9,6 | 9,6 | 7,9 |
| Efficiency at T2N, gearbox temperature 70 °C and n1=1,000rpm | η | % | 95 | 94 | 93 | 93 | 93 | 92 | 92 | 90 | 80 |
| Running noise at n1=3,000 rpm without load at a distance of 1m | Q_g | dB(A) | 73 | 73 | 73 | 73 | 73 | 73 | 73 | 73 | 73 |
| Gearbox weight | m_G | kg | 4,2 | 4,2 | 4,2 | 4,1 | 4,2 | 4,2 | 4,2 | 4,2 | 4,2 |
| Mass moment of inertia based on clamping system diameter input | J | kgcm ² | 1,184 | 1,161 | 1,157 | 0,948 | 0,908 | 0,906 | 0,869 | 0,868 | 0,869 |

$$(1) \text{ Max. motor weight* in kg} = \frac{0,2 \times M_b}{\text{motor length in m}}$$

- * with symmetrically distributed motor weight
- * with horizontal and stationary mounting

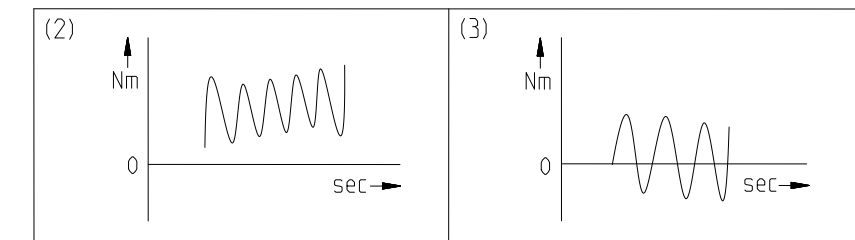

(5) Different lifetime: 10,000h at T2N

Subject to modifications.



WPLE080-bii-SSSA3AE-Y(D20)
/(L20)/(D21)/(D22)/B5/(G3)

Sheet 2/2

Revision status: H from: 08/2022