

Materials / Surfaces:

Input flange: Aluminum / untreated
 Angle housing: Aluminum / untreated
 Housing: Steel / heat-treated and post-oxidized (black)
 Output flange: Aluminum / untreated

Hints:

Please pay attention to the operating and mounting instructions.
 Subject to modifications.

Variables on the drawing are dependent upon the motor.
 The given dimensions are exemplary.

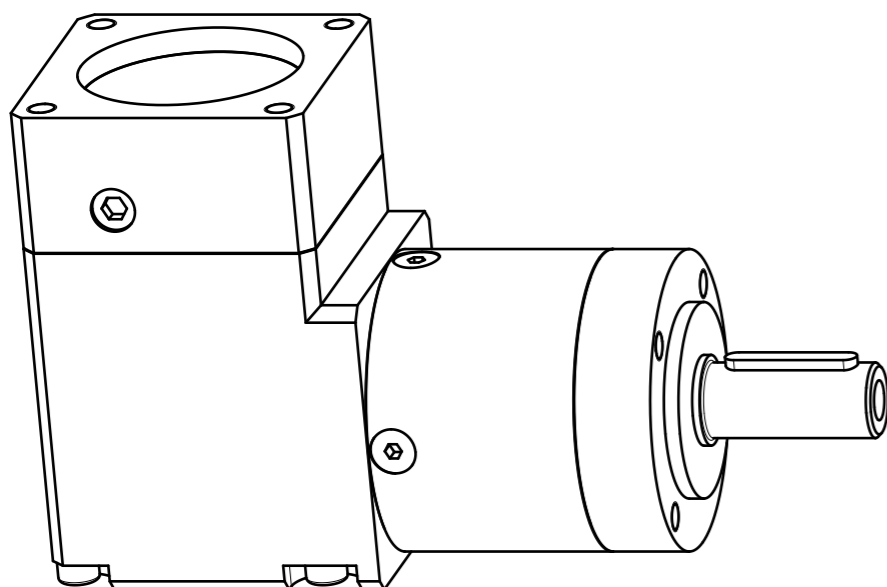
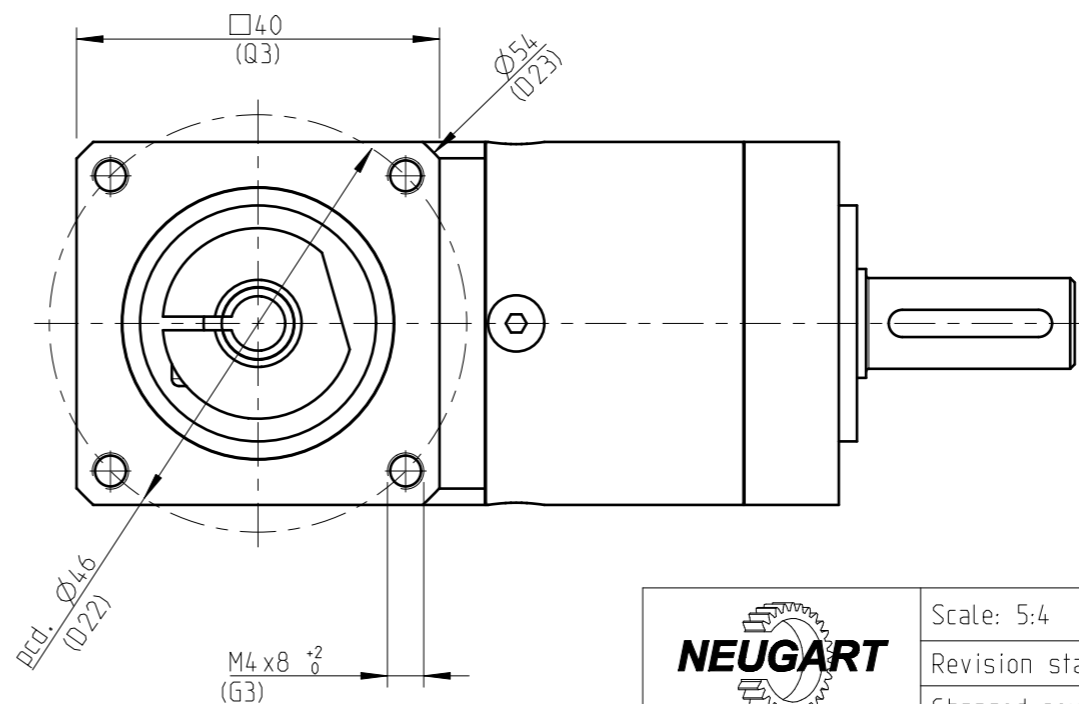

	Scale: 5:4	DIN A3	ISO
	Revision status: H from: 08/2022		
Changed revision status: G from: 01/2022			
General tolerance DIN ISO 2768-cL	WPLE040-aii-SSSA3AA-Y(D20) /(L20)/(D21)/(D22)/B5/(G3)		
Neugart GmbH Keltenstr. 16 D-77971 Kippenheim			Sheet 1/2

General gearbox data	Character	Unit	
Bevel gearbox - gearing type	-	-	Straight teeth
Rotation direction	-	-	Input and output in the same direction
Number of stages	p	-	1-stage
Output shaft bearing	-	-	Deep groove ball bearing
Service life (L10h)	t_L	h	20.000
Max. operating temperature	T_{min} / T_{max}	°C	-25 / +90
Protection class	-	-	IP 54
Right angle gearbox lubrication (lubricated for life)	-	-	Standard lubrication (KLüberplex BEM 34-132)
Planetary gearbox lubrication (lubricated for life)	-	-	Standard lubrication (KLübersynth GE 14-112)
Installation position	-	-	Any
Max. bending moment based on the gearbox input flange (for motor weight) (1)	M_b	Nm	2
Motor shaft concentricity / Coaxiality and axial runout Motor flange	-	mm	0,03 / 0,06 (Measuring methods according to DIN EN 50347)
Required motor shaft tolerance	-	-	j6; k6
Min. permissible motor shaft length	$L_{20 min}$	mm	17
Reference operating mode	-	-	S1
Reference operating factor	K_A	-	1
Reference speed	n_2	rpm	100
Reference ambient temperature	T_{Amb}	°C	20
Radial force for output bearing based on shaft center after L10h=20,000h with Fa=0N	$F_r 20.000h$	N	200
Axial force for output bearing based on gearbox axis after L10h=20,000h with Fr=0N	$F_a 20.000h$	N	200
Radial force for output bearing based on shaft center after L10h=30,000h with Fa=0N	$F_r 30.000h$	N	160
Axial force for output bearing based on gearbox axis after L10h=30,000h with Fr=0N	$F_a 30.000h$	N	160
Maximum radial force based on shaft center and T2=0Nm	$F_r Max$	N	200
Maximum axial force based on gearbox axis and T2=0Nm	$F_a Max$	N	240

Ratio-dependent gearbox data	Character	Unit							
Ratio	aii	-	3	4	5	7	8	10	
Nominal output torque No alternating torque (2)	T_{2N}	Nm	4,5	6	7,5	8,5	6	5	
Nominal output torque Alternating torque permitted for 10,000,000 load changes (3)	$T_{2N 10Mio}$	Nm	4,5	6	7,5	8,5	6	5	
Nominal output torque Alternating torque permitted for 100,000,000 load changes (3)	$T_{2N 100Mio}$	Nm	4,5	6	7	7	6	5	
Max. output torque for 30,000 output shaft rotations (2)	T_{2max}	Nm	7	10	12	13,5	10	8	
Emergency stop torque permitted 1000 times	T_{2Stop}	Nm	22,5	28	35	26	27	25	
Average idle torque for $n_1=3,000$ rpm and 20 °C gearbox temperature	T_0	Nm	0,05	0,05	0,05	0,05	0,05	0,05	
Average thermal input speed at 50% T2N, S1, and T_Amb Operating temperature may not be exceeded!	$n_{1N 50\%}$	rpm	5000	5000	5000	5000	5000	5000	
Average thermal input speed at 100% T2N, S1, and T_Amb Operating temperature may not be exceeded!	$n_{1N 100\%}$	rpm	5000	5000	5000	5000	5000	5000	
Max. mechanical input speed Operating temperature may not be exceeded!	$n_{1 Limit}$	rpm	18000	18000	18000	18000	18000	18000	
Torsional backlash based on output shaft	j_t	arcmin	< 21	< 21	< 21	< 21	< 21	< 21	
Torsional stiffness based on output shaft	c_g	Nm/arcmin	0,45	0,6	0,7	0,75	0,75	0,7	
Efficiency at T2N, gearbox temperature 70 °C and $n_1=1,000$ rpm	η	%	94	94	94	94	92	90	
Running noise at $n_1=3,000$ rpm without load at a distance of 1m	Q_g	dB(A)	68	68	68	68	68	68	
Gearbox weight	m_G	kg	0,55	0,55	0,55	0,55	0,55	0,55	
Mass moment of inertia based on clamping system diameter input	J	kgcm ²	0,049	0,041	0,035	0,033	0,032	0,032	

$$(1) \text{ Max. motor weight* in kg} = \frac{0,2 \times M_b}{\text{motor length in m}}$$

- * with symmetrically distributed motor weight
- * with horizontal and stationary mounting

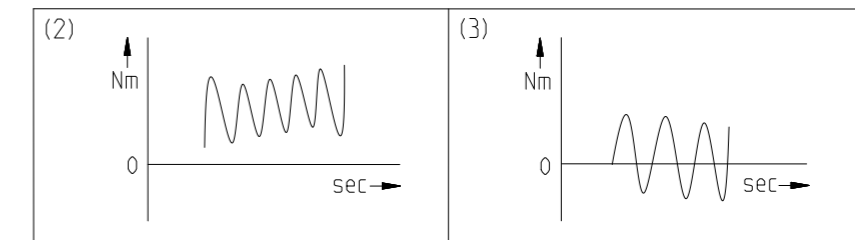

Subject to modifications.



WPLE040-aii-SSSA3AA-Y(D20)
/(L20)/(D21)/(D22)/B5/(G3)

Sheet 2/2

Revision status: H from: 08/2022