

Materials / Surfaces:

Input flange: Aluminum / untreated
 Housing: Steel / heat-treated and post-oxidized (black)
 Output flange: Steel / heat-treated and post-oxidized (black)

Hints:

Please pay attention to the operating and mounting instructions.
 Subject to modifications.

Variables on the drawing are dependent upon the motor.
 The given dimensions are exemplary.

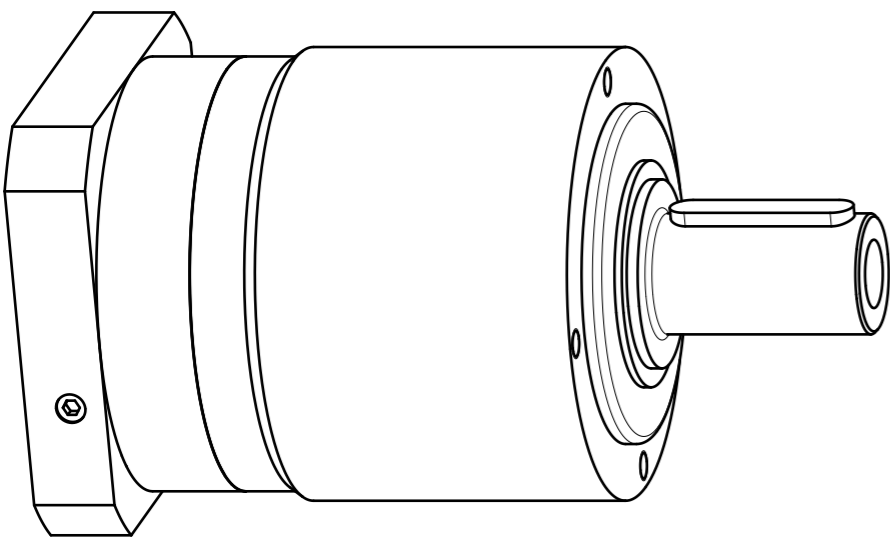

	Scale: 3:5	DIN A3	ISO
	Revision status: H from: 07/2022		
	Changed revision status: G from: 12/2021		
General tolerance DIN ISO 2768-cL	PLPE120-bii-SSSA3AF-Z(D20) /(L20)/(D21)/(D22)/B5/(G3)		
Neugart GmbH Keltenstr. 16 D-77971 Kippenheim			Sheet 1/2

General gearbox data	Character	Unit	
Planetary gearbox - gearing type	-	-	Straight teeth
Rotation direction	-	-	Input and output in the same direction
Number of stages	p	-	2-stage
Output shaft bearing	-	-	Deep groove ball bearing
Service life (L10h)	t_L	h	30.000
Max. operating temperature	T_{min} / T_{max}	°C	-25 / +90
Protection class	-	-	IP 54
Lubrication (lifetime lubrication)	-	-	Standard lubrication (Klübersynth GE 14-112)
Installation position	-	-	Any
Max. bending moment based on the gearbox input flange (for motor weight) (1)	M_b	Nm	40
Motor shaft concentricity / Coaxiality and axial runout Motor flange	-	mm	0,04 / 0,08 (Measuring methods according to DIN EN 50347)
Required motor shaft tolerance	-	-	j6; k6
Min. permissible motor shaft length	$L_{20 min}$	mm	19
Reference operating mode	-	-	S1
Reference operating factor	K_A	-	1
Reference speed	n_2	rpm	100
Reference ambient temperature	T_{Amb}	°C	20
Radial force for output bearing based on shaft center after L10h=20,000h with Fa=0N	$F_r 20.000h$	N	2500
Axial force for output bearing based on gearbox axis after L10h=20,000h with Fr=0N	$F_a 20.000h$	N	4000
Radial force for output bearing based on shaft center after L10h=30,000h with Fa=0N	$F_r 30.000h$	N	2150
Axial force for output bearing based on gearbox axis after L10h=30,000h with Fr=0N	$F_a 30.000h$	N	3000
Maximum radial force based on shaft center and T2=0Nm	$F_r Max$	N	4000
Maximum axial force based on gearbox axis and T2=0Nm	$F_a Max$	N	5900

$$(1) \text{ Max. motor weight* in kg} = \frac{0,2 \times M_b}{\text{motor length in m}}$$

- * with symmetrically distributed motor weight
- * with horizontal and stationary mounting

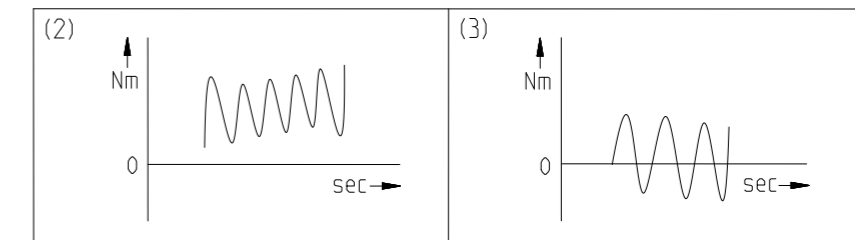

Ratio-dependent gearbox data	Character	Unit										
Ratio	bii	-	9	12	15	16	20	25	32	40	64	100
Nominal output torque No alternating torque (2)	T_{2N}	Nm	157	195	172	195	195	172	195	172	120	95
Nominal output torque Alternating torque permitted for 10,000,000 load changes (3)	$T_{2N 10Mio}$	Nm	157	195	172	195	195	172	195	172	120	95
Nominal output torque Alternating torque permitted for 100,000,000 load changes (3)	$T_{2N 100Mio}$	Nm	157	190	172	190	190	172	190	172	120	95
Max. output torque for 30,000 output shaft rotations (2)	T_{2max}	Nm	251	312	275	312	312	275	312	275	192	152
Emergency stop torque permitted 1000 times	T_{2stop}	Nm	500	520	500	520	520	500	520	500	380	480
Average idle torque for $n_1=3,000$ rpm and 20 °C gearbox temperature	T_0	Nm	0,85	0,8	0,75	0,75	0,65	0,6	0,5	0,5	0,45	0,45
Average thermal input speed at 50% T2N, S1, and T_Amb Operating temperature may not be exceeded!	$n_{1N 50\%}$	rpm	3500	3500	3500	3500	3500	3500	3500	3500	3500	3500
Average thermal input speed at 100% T2N, S1, and T_Amb Operating temperature may not be exceeded!	$n_{1N 100\%}$	rpm	2700	2750	3250	3200	3500	3500	3500	3500	3500	3500
Max. mechanical input speed Operating temperature may not be exceeded!	$n_{1 Limit}$	rpm	6500	6500	6500	6500	6500	6500	6500	6500	6500	6500
Torsional backlash based on output shaft	j_t	arcmin	< 9	< 9	< 9	< 9	< 9	< 9	< 9	< 9	< 9	< 9
Torsional stiffness based on output shaft	c_g	Nm/arcmin	34	39,5	37,5	40	40	37,5	39,5	37,5	30	21
Efficiency at T2N, gearbox temperature 70 °C and $n_1=1,000$ rpm	η	%	96	96	96	96	95	95	94	93	89	83
Running noise at $n_1=3,000$ rpm without load at a distance of 1m	Q_g	dB(A)	65	65	65	65	65	65	65	65	65	65
Gearbox weight	m_G	kg	9,3	9,3	9,4	9,3	9,4	9,4	9,4	9,5	9,5	9,6
Mass moment of inertia based on clamping system diameter input	J	kgcm ²	2,334	2,248	2,218	1,76	1,582	1,571	1,423	1,419	1,415	1,376

Subject to modifications.



PLPE120-bii-SSSA3AF-Z(D20)
/(L20)/(D21)/(D22)/B5/(G3)

Sheet 2/2

Revision status: H from: 07/2022