

Flange output shaft (similar EN ISO 9409-1)

Materials / Surfaces:

Input flange: Aluminum / untreated
 Housing: Steel / heat-treated and post-oxidized (black)
 Output flange: Steel / untreated

Hints:

Please pay attention to the operating and mounting instructions.
 Subject to modifications.

Variables on the drawing are dependent upon the motor.
 The given dimensions are exemplary.

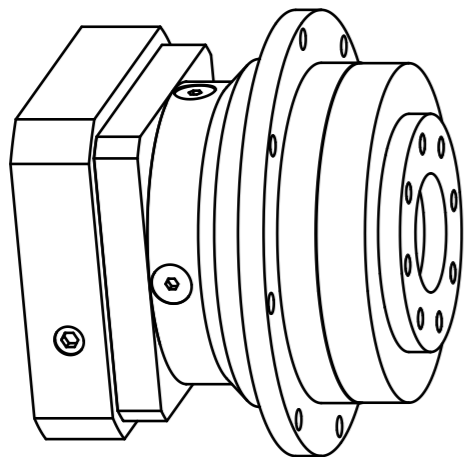

	Scale: 7:10	DIN A3	ISO
	Revision status: C from: 02/2022		
	Changed revision status: B from: 09/2020		
General tolerance DIN ISO 2768-cl	PFHE090-aii-SSSD3AE-Y(D20) /(L20)/(D21)/(D22)/B5/(G3)		
Neugart GmbH Keltenstr. 16 D-77971 Kippenheim			Sheet 1/2

General gearbox data	Character	Unit	
Planetary gearbox - gearing type	-	-	Straight teeth
Rotation direction	-	-	Input and output in the same direction
Number of stages	p	-	1-stage
Output shaft bearing	-	-	Inclined roller bearings
Service Life (L10h)	t_L	h	30.000
Max. operating temperature	T_{min} / T_{max}	°C	-25 / +90
Protection class	-	-	IP 65
Lubrication (Lifetime Lubrication)	-	-	Standard Lubrication (Klübersynth GE 14-112)
Installation position	-	-	Any
Max. bending moment based on the gearbox input flange (for motor weight) (1)	M_b	Nm	16
Motor shaft concentricity / Coaxiality and axial runout Motor flange	-	mm	0,04 / 0,08 (Measuring methods according to DIN EN 50347)
Required motor shaft tolerance	-	-	j6; k6
Min. permissible motor shaft length	$L_{20 min}$	mm	19
Reference operating mode	-	-	S1
Reference operating factor	K_A	-	1
Reference speed	n_2	rpm	100
Reference ambient temperature	T_{Amb}	°C	20
Radial force for output bearing based on shaft end after L10h=20,000h with Fa=0N	$F_r 20.000h$	N	4100
Axial force for output bearing based on gearbox axis after L10h=20,000h with Fr=0N	$F_a 20.000h$	N	5450
Radial force for output bearing based on shaft end after L10h=30,000h with Fa=0N	$F_r 30.000h$	N	3650
Axial force for output bearing based on gearbox axis after L10h=30,000h with Fr=0N	$F_a 30.000h$	N	4800
Maximum radial force based on shaft end and T2=0Nm	$F_r Max$	N	4100
Maximum axial force based on gearbox axis and T2=0Nm	$F_a Max$	N	5450

$$(1) \text{ Max. motor weight* in kg} = \frac{0,2 \times M_b}{\text{motor length in m}}$$

- * with symmetrically distributed motor weight
- * with horizontal and stationary mounting

Ratio-dependent gearbox data	Character	Unit							
Ratio	aii	-	3	4	5	7	8	10	
Nominal output torque	T_{2N}	Nm	85	115	110	65	50	38	
Max. output torque for 30,000 output shaft rotations	T_{2max}	Nm	136	184	176	104	80	61	
Emergency stop torque permitted 1000 times	T_{2Stop}	Nm	180	240	220	178	190	200	
Average idle torque for n1=3,000 rpm and 20 °C gearbox temperature	T_0	Nm	1,75	1,2	0,9	0,6	0,55	0,45	
Average thermal input speed at 50% T2N, S1, and T_Amb Operating temperature may not be exceeded!	$n_{1N 50\%}$	rpm	1900	2200	2750	4000	4000	4000	
Average thermal input speed at 100% T2N, S1, and T_Amb Operating temperature may not be exceeded!	$n_{1N 100\%}$	rpm	1550	1700	2100	3550	4000	4000	
Max. mechanical input speed Operating temperature may not be exceeded!	$n_{1 Limit}$	rpm	7000	7000	7000	7000	7000	7000	
Torsional backlash based on output shaft	j_f	arcmin	< 7	< 7	< 7	< 7	< 7	< 7	
Torsional stiffness based on output shaft	c_g	Nm/arcmin	16,1	31	32,5	21	20	16,8	
Efficiency at T2N, gearbox temperature 70 °C and n1=1,000rpm	η	%	97	97	97	96	96	95	
Running noise at n1=3,000 rpm without load at a distance of 1m	Q_g	dB(A)	62	62	62	62	62	62	
Gearbox weight	m_G	kg	3,1	3,1	3,1	3,1	3,1	3,1	
Mass moment of inertia based on clamping system diameter input	J	kgcm ²	1,17	0,767	0,612	0,475	0,444	0,407	



PFHE090-aii-SSSD3AE-Y(D20)
/(L20)/(D21)/(D22)/B5/(G3)

Sheet 2/2

Subject to modifications.

Revision status: C from: 02/2022