

Flange output shaft (similar EN ISO 9409-1)

Materials / Surfaces:

Input flange: Aluminum / untreated
 Housing: Steel / heat-treated and post-oxidized (black)
 Output flange: Steel / untreated

Hints:

Please pay attention to the operating and mounting instructions.
 Subject to modifications.

Variables on the drawing are dependent upon the motor.
 The given dimensions are exemplary.

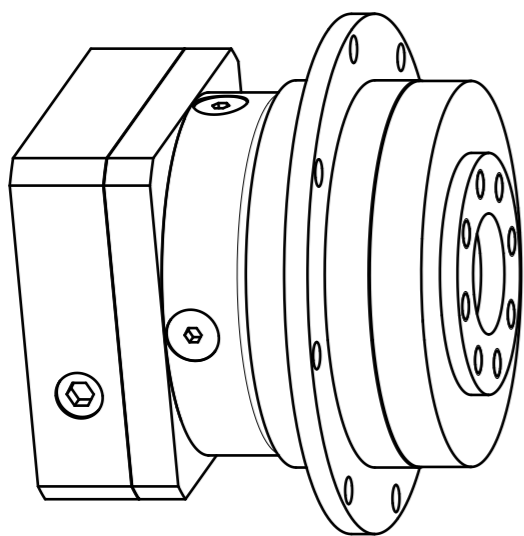

	Scale: 1:1	DIN A3	ISO
	Revision status: C from: 02/2022		
	Changed revision status: B from: 09/2020		
General tolerance DIN ISO 2768-cL	PFHE064-aii-SSSD3AD-Y(D20) /(L20)/(D21)/(D22)/B5/(G3)		
Neugart GmbH Keltenstr. 16 D-77971 Kippenheim			Sheet 1/2

General gearbox data	Character	Unit	
Planetary gearbox - gearing type	-	-	Straight teeth
Rotation direction	-	-	Input and output in the same direction
Number of stages	p	-	1-stage
Output shaft bearing	-	-	Inclined roller bearings
Service Life (L10h)	t_L	h	30.000
Max. operating temperature	T_{min} / T_{max}	°C	-25 / +90
Protection class	-	-	IP 65
Lubrication (Lifetime Lubrication)	-	-	Standard lubrication (Klübersynth GE 14-112)
Installation position	-	-	Any
Max. bending moment based on the gearbox input flange (for motor weight) (1)	M_b	Nm	8
Motor shaft concentricity / Coaxiality and axial runout Motor flange	-	mm	0,03 / 0,06 (Measuring methods according to DIN EN 50347)
Required motor shaft tolerance	-	-	j6; k6
Min. permissible motor shaft length	$L_{20 min}$	mm	14,5
Reference operating mode	-	-	S1
Reference operating factor	K_A	-	1
Reference speed	n_2	rpm	100
Reference ambient temperature	T_{Amb}	°C	20
Radial force for output bearing based on shaft end after L10h=20,000h with Fa=0N	$F_r 20.000h$	N	2300
Axial force for output bearing based on gearbox axis after L10h=20,000h with Fr=0N	$F_a 20.000h$	N	2850
Radial force for output bearing based on shaft end after L10h=30,000h with Fa=0N	$F_r 30.000h$	N	2000
Axial force for output bearing based on gearbox axis after L10h=30,000h with Fr=0N	$F_a 30.000h$	N	2500
Maximum radial force based on shaft end and T2=0Nm	$F_r Max$	N	2300
Maximum axial force based on gearbox axis and T2=0Nm	$F_a Max$	N	2850

$$(1) \text{ Max. motor weight* in kg} = \frac{0,2 \times M_b}{\text{motor length in m}}$$

- * with symmetrically distributed motor weight
- * with horizontal and stationary mounting

Ratio-dependent gearbox data	Character	Unit						
Ratio	aii	-	3	4	5	7	8	10
Nominal output torque	T_{2N}	Nm	28	38	40	25	18	15
Max. output torque for 30,000 output shaft rotations	T_{2max}	Nm	45	61	64	40	29	24
Emergency stop torque permitted 1000 times	T_{2Stop}	Nm	66	88	80	80	80	80
Average idle torque for n1=3,000 rpm and 20 °C gearbox temperature	T_0	Nm	0,85	0,6	0,45	0,35	0,3	0,25
Average thermal input speed at 50% T2N, S1, and T_Amb Operating temperature may not be exceeded!	$n_{1N 50\%}$	rpm	2350	2950	3550	4500	4500	4500
Average thermal input speed at 100% T2N, S1, and T_Amb Operating temperature may not be exceeded!	$n_{1N 100\%}$	rpm	2100	2450	2950	4500	4500	4500
Max. mechanical input speed Operating temperature may not be exceeded!	$n_1 Limit$	rpm	7500	7500	7500	7500	7500	7500
Torsional backlash based on output shaft	j_f	arcmin	< 10	< 10	< 10	< 10	< 10	< 10
Torsional stiffness based on output shaft	c_g	Nm/arcmin	6,9	9,2	10,3	7,2	6,9	5,4
Efficiency at T2N, gearbox temperature 70 °C and n1=1,000rpm	η	%	96	96	96	95	94	93
Running noise at n1=3,000 rpm without load at a distance of 1m	Q_g	dB(A)	60	60	60	60	60	60
Gearbox weight	m_G	kg	1,15	1,15	1,15	1,15	1,15	1,15
Mass moment of inertia based on clamping system diameter input	J	kgcm ²	0,245	0,166	0,135	0,107	0,101	0,094



PFHE064-aii-SSSD3AD-Y(D20)
/(L20)/(D21)/(D22)/B5/(G3)

Sheet 2/2

Subject to modifications.

Revision status: C from: 02/2022