

**Materials / Surfaces:**

Input flange: Aluminum / untreated  
 Housing: Steel / heat treated and post-oxidized (black)  
 Output flange: Aluminum / untreated

**Hints:**

Please pay attention to the operating and mounting instructions.  
 Subject to modifications.

Variables on the drawing are dependent upon the motor.  
 The given dimensions are exemplary.

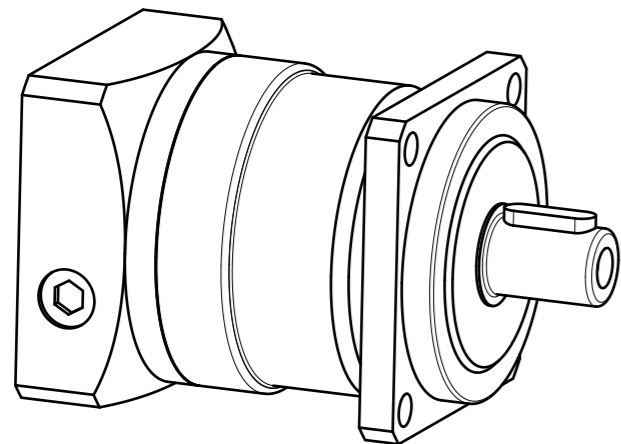

	Scale: 1:1	DIN A3	ISO
	Revision status: D from: 11/2024		
General tolerance DIN ISO 2768-cL	PSBN055-aii-SSSA3AC-Z(D20) /(L20)/(D21)/(D22)/B5/(G3)		
Neugart GmbH Keltenstr. 16 D-77971 Kippenheim			Sheet 1/2

General gearbox data		Unit	
Planetary gearbox - gearing type	-	-	Helical teeth
Rotation direction	-	-	Input and output in the same direction
Number of stages	p	-	1-stage
Output shaft bearing	-	-	Deep groove ball bearing
Service life (L10h)	-	h	20.000
Max. operating temperature	T <sub>min</sub> / T <sub>max</sub>	°C	-25 / +90
Protection class	-	-	IP 65
Lubrication (lifetime lubrication)	-	-	Standard lubrication (Castrol Optigear Synthetic 800/220)
Installation position	-	-	Any
Max. bending moment based on the gearbox input flange (for motor weight) (1)	M <sub>b</sub>	Nm	10
Motor shaft concentricity / Coaxiality and axial runout Motor flange	-	mm	0,015 / 0,03 (Measuring methods according to operating manual)
Required motor shaft tolerance	-	-	j6; k6
Min. permissible motor shaft length	L <sub>20 min</sub>	mm	15
Reference operating mode	-	-	S1
Reference operating factor	K <sub>A</sub>	-	1
Reference speed	n <sub>2</sub>	rpm	100
Reference ambient temperature	T <sub>Amb</sub>	°C	20
Radial force for output bearing based on shaft center after L10h=20,000h with Fa=0N	F <sub>r 20.000h</sub>	N	640
Axial force for output bearing based on gearbox axis after L10h=20,000h with Fr=0N	F <sub>a 20.000h</sub>	N	800
Radial force for output bearing based on shaft center after L10h=30,000h with Fa=0N	F <sub>r 30.000h</sub>	N	560
Axial force for output bearing based on gearbox axis after L10h=30,000h with Fr=0N	F <sub>a 30.000h</sub>	N	800
Maximum radial force based on shaft center and T2=0Nm	F <sub>r Max</sub>	N	830
Maximum axial force based on gearbox axis and T2=0Nm	F <sub>a Max</sub>	N	800

$$(1) \text{ Max. motor weight* in kg} = \frac{0,2 \times M_b}{\text{motor length in m}}$$

- \* with symmetrically distributed motor weight
- \* with horizontal and stationary mounting

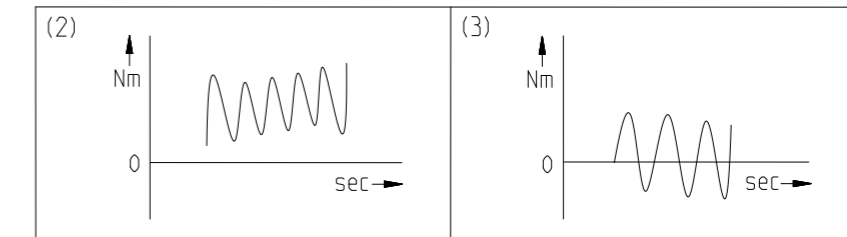

Ratio-dependent gearbox data		Character	Unit						
Ratio	iii	-		3	4	5	7	8	10
Nominal output torque No alternating torque (2)	T <sub>2N</sub>	Nm		11	18	18	18	18	13,5
Nominal output torque Alternating torque permitted for 10,000,000 load changes (3)	T <sub>2N 10Mio</sub>	Nm		11	18	18	18	18	13,5
Nominal output torque Alternating torque permitted for 100,000,000 load changes (3)	T <sub>2N 100Mio</sub>	Nm		11	15	15	15	15	13,5
Max. output torque for 30,000 output shaft rotations (2)	T <sub>2max</sub>	Nm		18	29	29	29	29	22
Emergency stop torque permitted 1000 times	T <sub>2Stop</sub>	Nm		48	48	48	48	48	24
Average idle torque for n1=3,000 rpm and 20 °C gearbox temperature	T <sub>0</sub>	Nm		0,25	0,25	0,2	0,15	0,15	0,15
Average thermal input speed at 50% T2N, S1, and T_Amb Operating temperature may not be exceeded!	n <sub>1N 50%</sub>	rpm		4950	5000	5000	5000	5000	5000
Average thermal input speed at 100% T2N, S1, and T_Amb Operating temperature may not be exceeded!	n <sub>1N 100%</sub>	rpm		4250	4300	4750	5000	5000	5000
Max. mechanical input speed Operating temperature may not be exceeded!	n <sub>1 Limit</sub>	rpm		10000	10000	10000	10000	10000	10000
Torsional backlash based on output shaft	j <sub>t</sub>	arcmin		< 6	< 6	< 6	< 6	< 6	< 6
Torsional stiffness based on output shaft	c <sub>g</sub>	Nm/arcmin		1,7	2	2	1,7	1,7	1,4
Efficiency at T2N, gearbox temperature 70 °C and n1=1,000rpm	η	%		96	97	96	95	95	93
Running noise at n1=3,000 rpm without load at a distance of 1m	Q <sub>g</sub>	dB(A)		62	56	56	56	56	56
Gearbox weight	m <sub>G</sub>	kg		0,85	0,8	0,8	0,8	0,8	0,8
Mass moment of inertia based on clamping system diameter input	J	kgcm <sup>2</sup>		0,133	0,113	0,105	0,099	0,098	0,096

Subject to modifications.



PSBN055-aii-SSSA3AC-Z(D20)  
/(L20)/(D21)/(D22)/B5/(G3)

Sheet 2/2

Revision status: D from: 11/2024