

Design Data	
Commutation	Brushed
Direction of rotation	Bi-directional
Bearing type	A:Ball - B:Sleeve

Performance data		
Rated voltage [V]	U_N	24
Nominal torque [Nm]	M_N	4.00
No-load speed [min^{-1}]	n_0	90.0
Nominal power [W]	P_N	35.9
Nominal current [A]	I_N	5.0
Nominal force [kN]	F_N	0.00
Duty cycle	s1	

Sensor data	
Pulses	69
Output channels	1

Other data	
Gear ratio	69/1
Gear wheel material	plastic
Suppression components	$6\mu\text{H}$, 1nF
Enclosure class	IP 30
Weight [kg]	1.210

Remarks: d=for thread forming screws M6 DIN-ISO 965-2

Characteristic curves

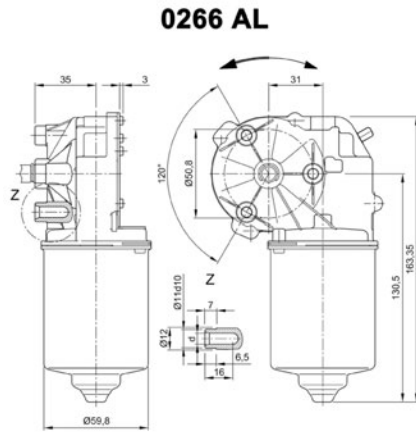

Motor picture

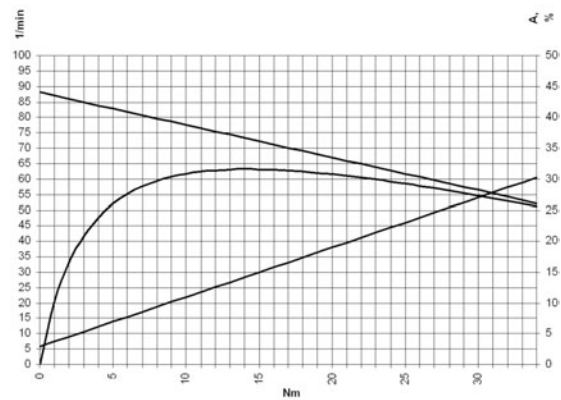

Output shaft drawing (W), Wiring diagrams (S) and Connector layout (K)

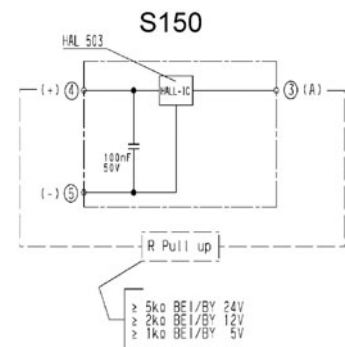
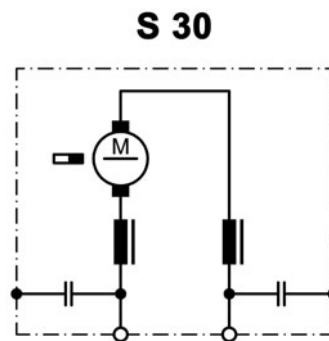
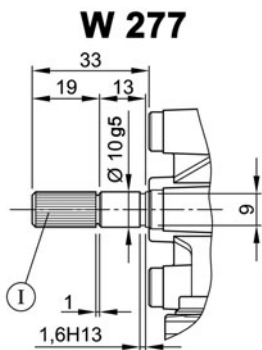

I serration (rolled)
 no of teeth 28, pitch circle dia 9 mm, tip circle dia 9.6 mm, root circle dia 8.26 mm space width angle 60°
 goes with go/no go gauge Frenco 33906
 www.frenco.de

