

Design Data	
Commutation	Brushed
Direction of rotation	Bi-directional
Bearing type	A:Ball- B:Sleeve

Performance data		
Rated voltage [V]	U_N	24
Nominal torque [Nm]	M_N	1.00
No-load speed [min^{-1}]	n_0	270.0
Nominal power [W]	P_N	24.5
Nominal current [A]	I_N	3.0
Nominal force [kN]	F_N	0.00
Duty cycle	s1	

Sensor data	
Pulses	10.25
Output channels	1

Other data	
Gear ratio	41/4
Gear wheel material	plastic
Suppression components	$6\mu\text{H}$, 1nF
Enclosure class	IP 30
Weight [kg]	1.250

Remarks: d = for thread-forming screw M6 DIN ISO 965-2

Characteristic curves

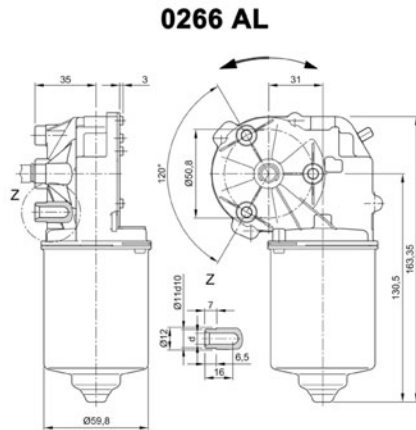

Motor picture

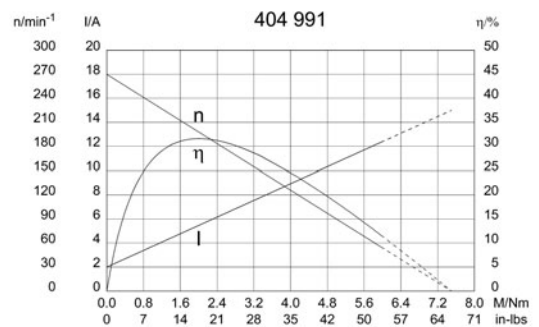

Output shaft drawing (W), Wiring diagrams (S) and Connector layout (K)

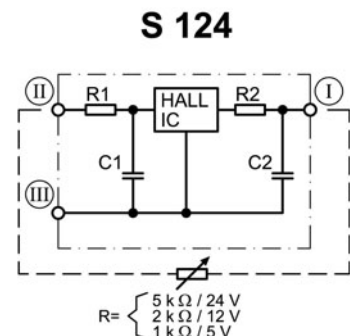
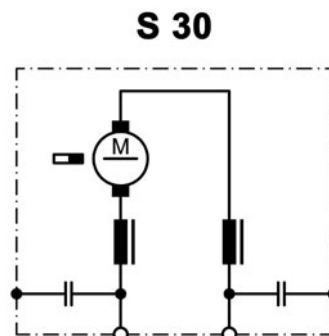
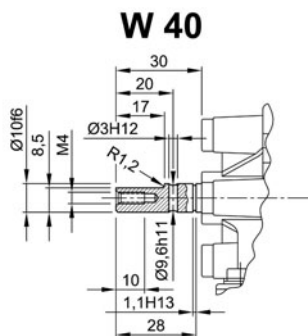

- I Terminal 3, A
- II Terminal 4, +
- III Terminal 5, -

