

Design Data	
Commutation	Brushed
Direction of rotation	Bi-directional
Bearing type	A: ball - B: sleeve

Performance data		
Rated voltage [V]	$U_N$	24
Nominal torque [Nm]	$M_N$	4.00
No-load speed [ $\text{min}^{-1}$ ]	$n_0$	36.0
Nominal power [W]	$P_N$	12.9
Nominal current [A]	$I_N$	3.0
Nominal force [kN]	$F_N$	0.00
Duty cycle	s1	

Sensor data	
Pulses	207
Output channels	1

Other data	
Gear ratio	69/1
Gear wheel material	plastic
Suppression components	$6\mu\text{H}$ , $1\text{nF}$
Enclosure class	IP 30
Weight [kg]	1.210

Remarks: d = for thread-forming screw M6 DIN ISO 965-2

#### Characteristic curves

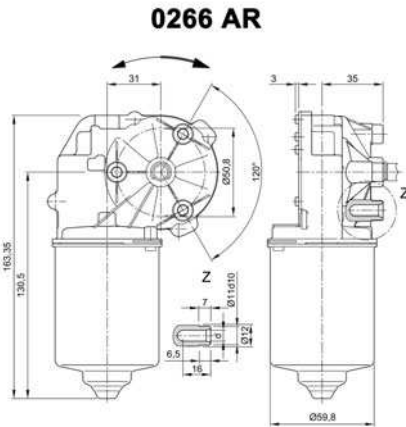

#### Motor picture

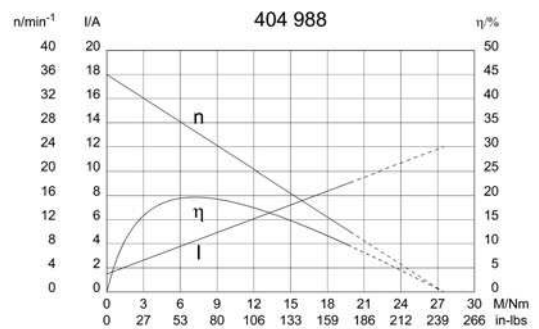

#### Output shaft drawing (W), Wiring diagrams (S) and Connector layout (K)

