

**BAR-SETTING
WORLD-CLASS
PERFORMANCE**

*Up to 100% Duty Cycle and
600 km of Maintenance-Free Life*



Electrak[®] LL

Long Life, High Duty Cycle Actuator
with Superior Environmental Protection

THOMSON[®]

Linear Motion. Optimized.™

A REGAL REXNORD BRAND



Electrak[®] LL – Long Life, High Duty Cycle Linear Actuator

Finding an affordable electric linear actuator with long life, high duty cycle and the ability to work in the harshest environments has been difficult for design engineers. With the new Electrak LL, the search is over, and new markets and applications have been opened for electric actuators.

Long Maintenance-Free Life

In order to make long life and no maintenance the top priorities for Electrak LL, Thomson's engineering team closely examined every function and component to develop the necessary improvements upon its predecessors.

- **NEW!** Efficient long-life brushless motor
- **NEW!** Built-in brushless motor drive system
- **NEW!** Specially designed onboard control, meeting railway safety standards*
- **NEW!** Long-life ball screw and nut assembly
- **NEW!** Long-life load-bearing design
- **NEW!** Long-life manual override design
- **NEW!** UV-resistant surface treatment
- Thomson's full Electronic Monitoring Package functionality
- All stainless steel external hardware

High Duty Cycle

The full load duty cycle for Electrak LL is 35%, and up to 100% at reduced load, which is significantly higher than comparable actuators. The combination of higher duty cycle and longer life makes Electrak LL well suited for many applications - most notably mobile battery powered ones - that previously have had to employ more expensive and complex solutions. Examples include:

- Pantograph control
- Lifting and positioning in mobile equipment
- Door, hatch and valve control
- Picking, placing and sorting
- Material handling
- Conveyor control

* Electrak LL complies to the railway standards EN 50155, EN 60077 and EN 4554.



Superior Environmental Protection

Electrak LL takes environmental protection to the next level, offering outstanding protection against dirt, chemicals and elements of nature.

- IP69K (static) and IP66 (static and dynamic) ratings prove Electrak LL can withstand the harshest environments
- Capable of operating in a wide temperature range from -40°C to +85°C (-40°F to +185°F)
- Salt spray tested for 500 hours
- CE, RoHS and REACH (EU) compliant
- Rated for IP-X6 (dynamic) during water splash at +10°C (+50°F) and an equalized actuator temperature of +85°C (+185°F)
- Solar radiation (UV) tested for 300 hours according to IEC 60068-2-5

Replacing Pneumatic or Fluid Power

Electrak LL's bevy of capabilities opens up new application opportunities where electric linear actuators can replace pneumatic and hydraulic cylinders. This results in benefits such as:

- Better controllability
- Space-saving designs
- Simplified engineering and installation
- Less energy usage leading to improved efficiency
- Cleaner and more environment friendly
- Little to no maintenance required





Thrives in Places Where Most Actuators Give Up

Electrak[®] LL was specially designed to ensure long and trouble-free operation in the toughest applications. Even by Thomson standards, Electrak LL stands out in this respect, and it will keep working where most other electric linear actuators bow out.

Thomson engineers have labored and scrutinized over the smallest of details to ensure that all Electrak LL parts meets the strictest environmental demands. The

result is a heavy duty actuator that can ensure up to 600 km (375 miles) of trouble-free duty in some of the worst conditions imaginable.

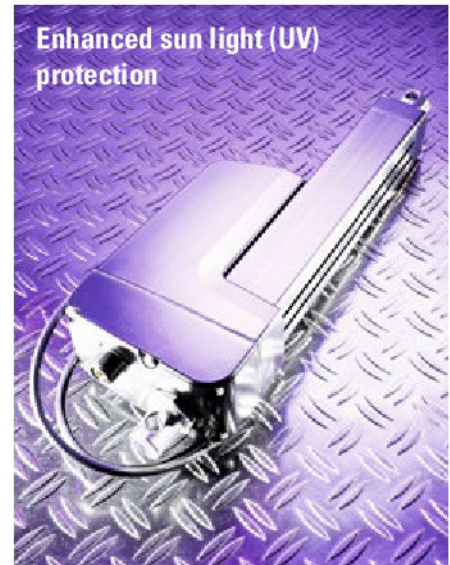
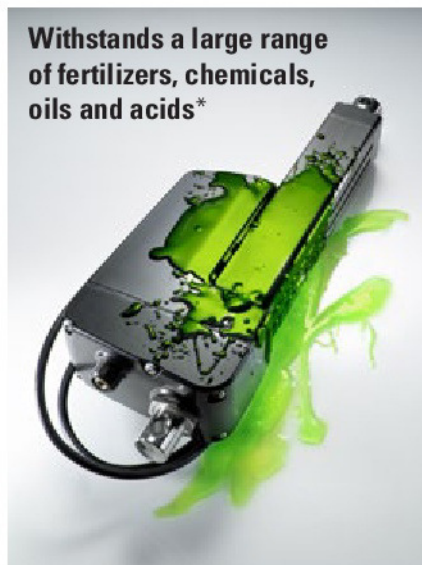
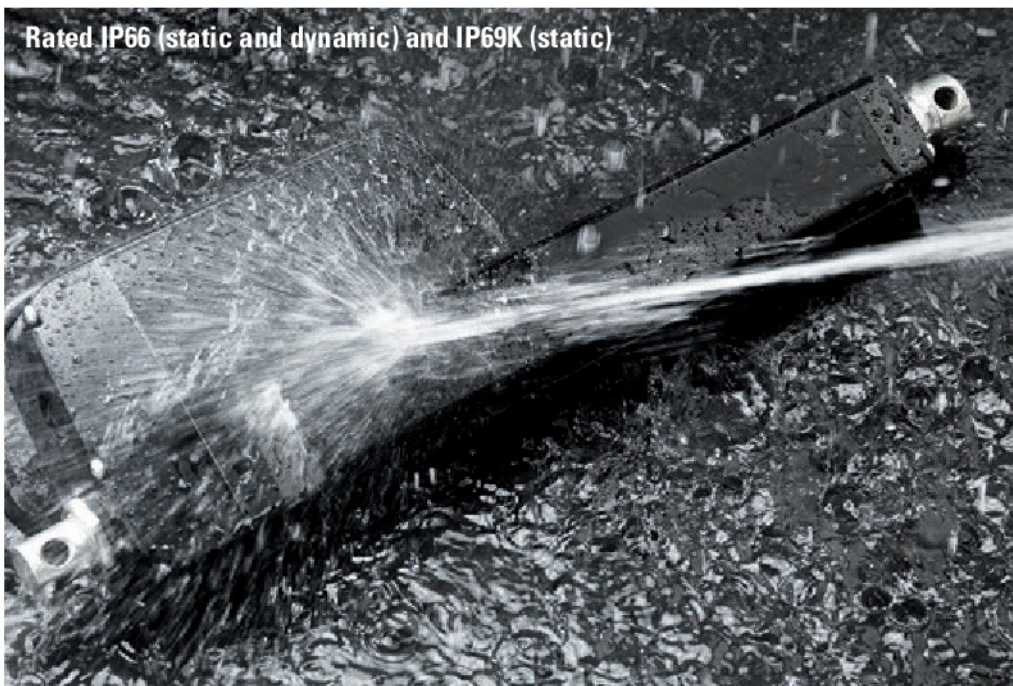

* Contact customer support for information on the resistance for specific substances

Travels Further at a Faster Pace

Not only is Electrak LL tough, but it is tenacious as well. With a life of up to 600 km and a duty cycle of up to 100%, these actuators can work longer and at a higher frequency than previous generations of actuators. This makes them ideal in applications where, if you were previously using a traditional electric actuator, you had to settle for shorter life and more maintenance, or turn to a more complex, expensive and bulkier pneumatic or hydraulic system.

Electrak linear actuators deliver many benefits, but they also carry some inherent limitations. Often these are related to the life and/or duty cycle of the actuators, which force engineers to opt for a pneumatic or hydraulic solution despite their many drawbacks. Now with its improved life and duty cycle, Electrak LL offers the full gamut of benefits and is equipped to tackle applications once thought impossible for electric actuators.

Longer Life

The theoretical maximum travel life of an Electrak LL actuator is 600 km (375 miles), which is more than 10 times longer than comparable actuators capable of the same load and speed. In order to calculate an exact as possible life expectancy for an actuator in a specific application, many more variables must be taken into account. Please contact Thomson customer support for assistance with these calculations.

Higher Duty Cycle

The Electrak LL full load duty cycle is 35%, which is 10 – 20% higher than for other comparable electric linear actuators, and at reduced load it can go up to 100%. That translates into more work done in a given timeframe without having to use forced cooling or a stronger and bigger actuator than the load requires just to avoid overheating.

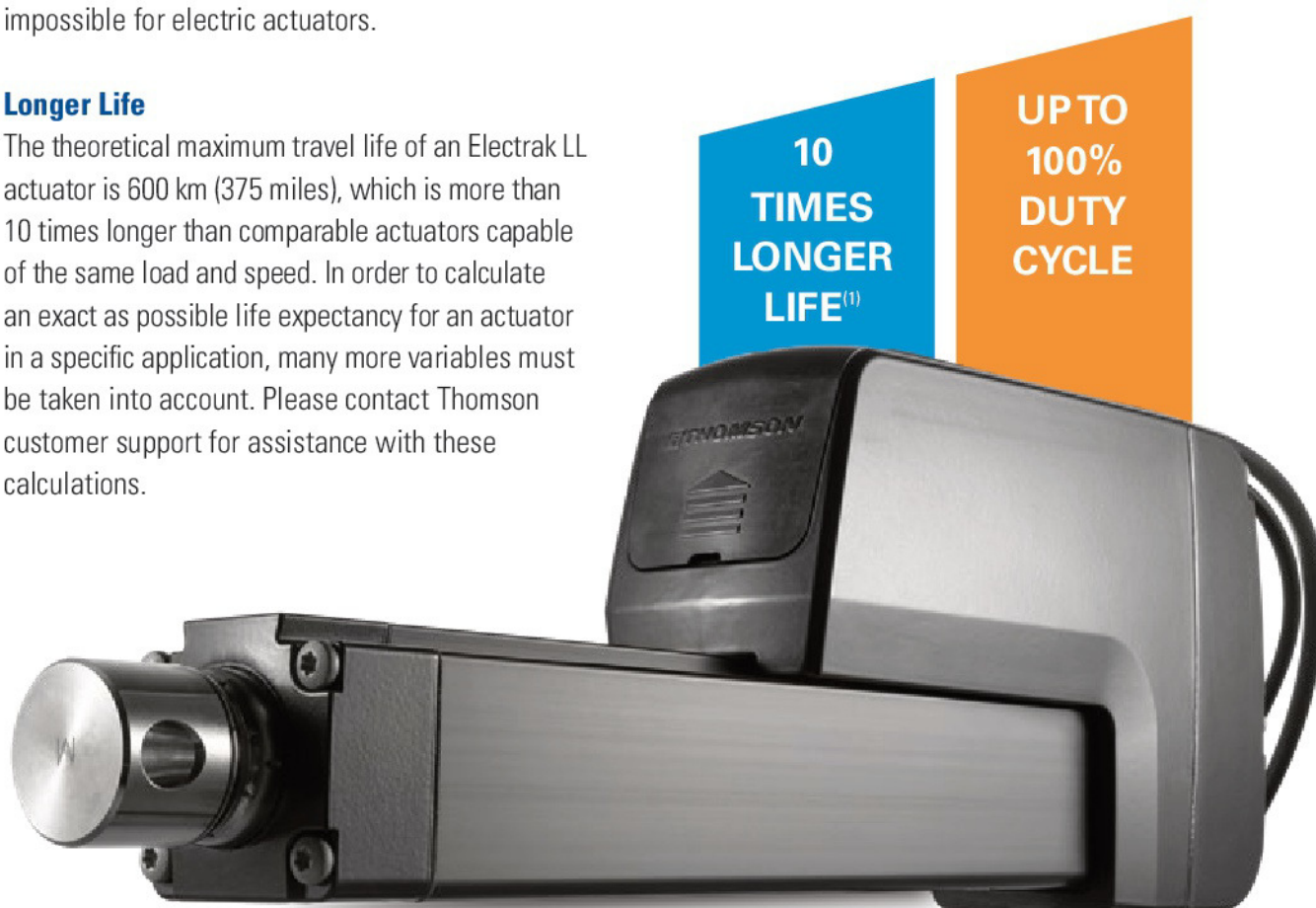



A Look Inside the Thomson Electrak® LL

What makes Electrak LL tick? In short, it is decades of accumulated electric actuator knowledge combined with state-of-the-art technologies, high-quality components and thorough testing done both in the lab and in the field.

LONGER LIFE

The best materials and the use of cutting-edge technologies deliver long and trouble-free life.

- 1 **Brushless DC motor with electromagnetic brake**
- 2 **New control board with tougher components**
- 3 **Longer life screw and nut assembly**
- 4 **New long-life, load-bearing design**
- 5 **New more robust manual override design**

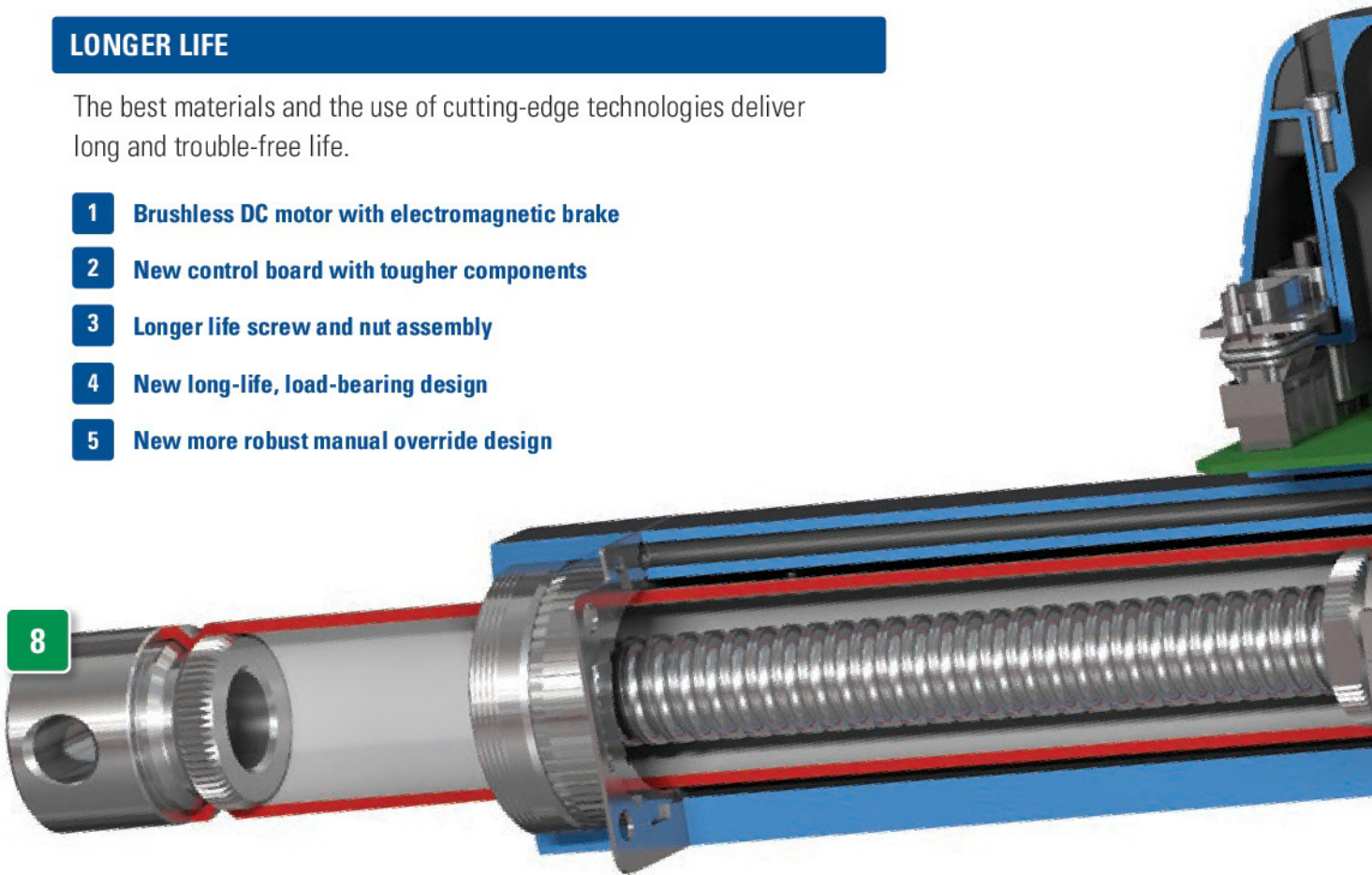

HIGHER DUTY CYCLE

Lower-friction components and a more efficient motor results in smoother operation and a higher duty cycle.

- 6 **More efficient motor and control**
- 7 **Higher quality screw and nut**

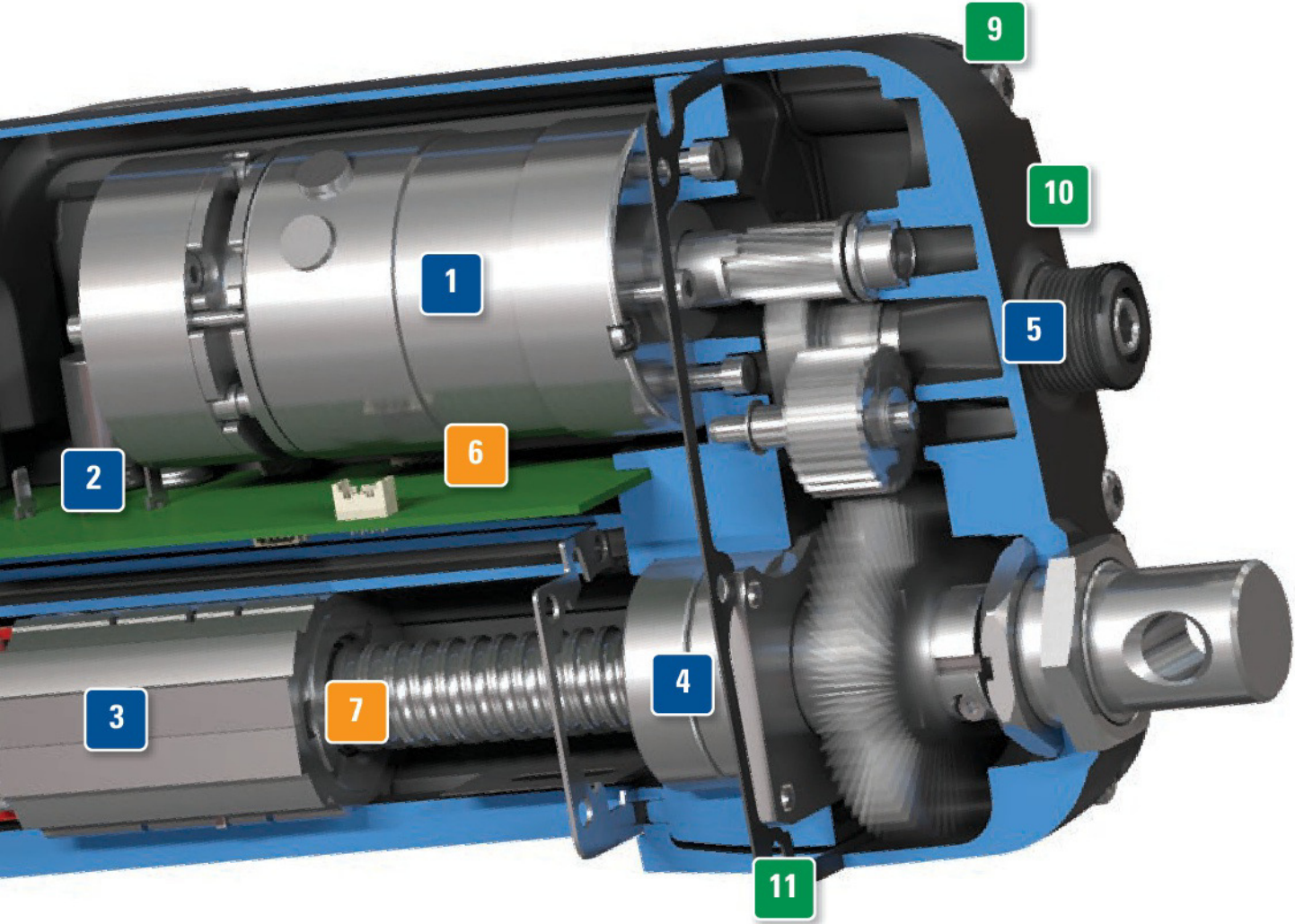

UPGRADED ENVIRONMENTAL PROTECTION

Tougher exterior hardware and improved surface treatment reduce the impact of the elements.

- 8 **Stainless steel adapters**
- 9 **Stainless steel hardware**
- 10 **Better UV-resistant surface treatment**
- 11 **Flame-retardant, halogen-free cables**



Ready for the Railway

Electrak® LL was designed with the railway market in mind. The standards and safety regulations for railway equipment can be very demanding and require rigorous testing to ensure compliance.

Railroad equipment is exposed to some of the toughest conditions. The Electrak LL actuator performs effectively despite harsh weather, heavy vibrations or high-pressure washing, making it ideal for opening and closing gravity bins or controlling a pantograph.

Railway Standards

The railway industry has its own safety standards and regulations for components and equipment used for critical operations. Electrak LL complies to the following railway standards:

- EN 50155
- EN 60077
- EN 45545

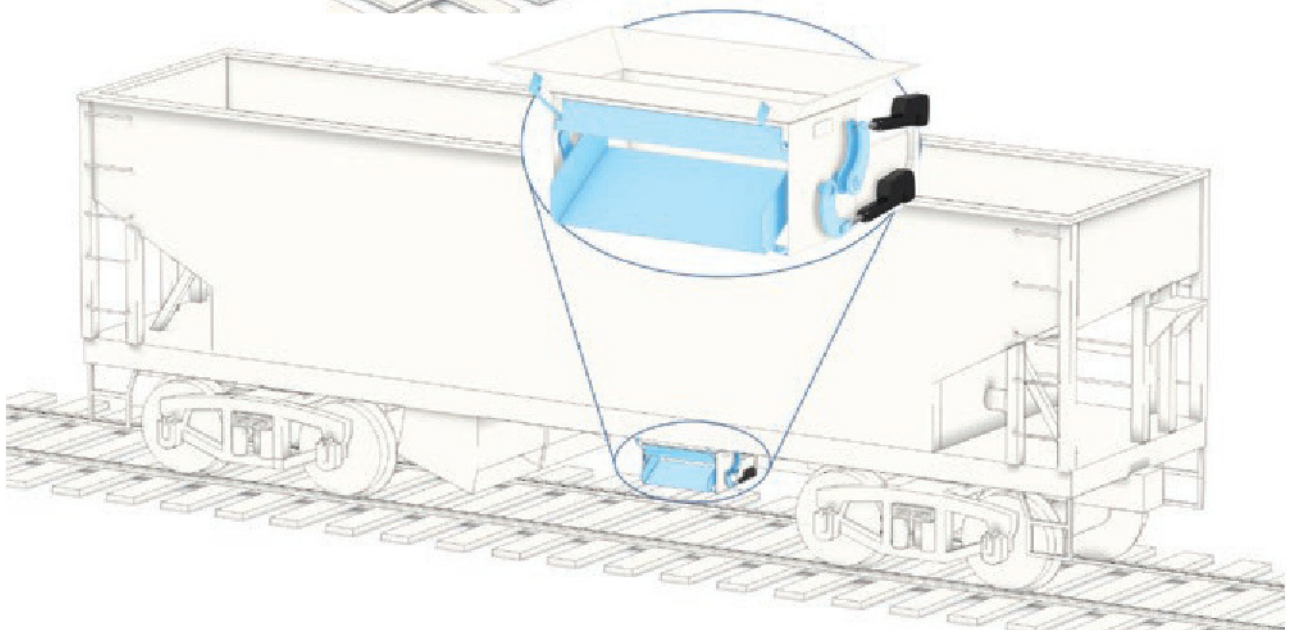
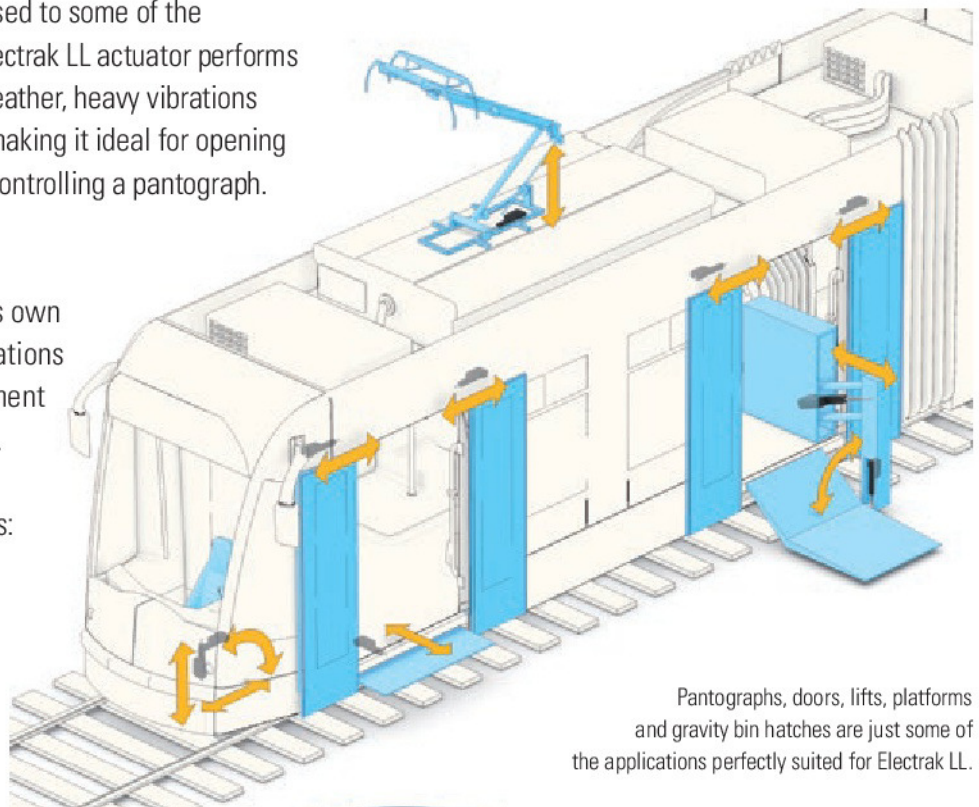

The Long Life Advantage

The long life of Electrak LL enables it to take on applications where before it may have been difficult or impossible to use electric linear actuators due to life expectancy constraints. This advantage is especially true for industrial applications where equipment is often put to work around the clock without any breaks.

Typical electric linear actuator applications have traditionally been those for low-frequency setup and adjustment operations since, in many cases, life may have been the limiting factor. Therefore, the only solution has been to upgrade to more expensive actuators that deliver higher overall performance. With life being the only improvement really needed though, the unfortunate result has been an over-performing and over-priced solution. Electrak LL now closes that gap, giving you the opportunity to realize long, reliable life at a reasonable cost for medium-frequency tasks.

Logistics and Material Handling

There are many industrial applications for which Electrak LL provides an ideal solution, but where it really excels are in applications in which medium-frequency work is done on a daily basis. Examples

are lifting, tilting and grabbing operations in AGVs, logistic trains and lift trucks, or in material handling machines operating a valve, hatch or cutter back and forth during a production cycle. Often these types of operations also require multiple actuators sharing the load, which can be a challenge due to uneven loads and resulting binding effects. With Electrak LL, it is an easier task since its speed is load independent and therefore constant.

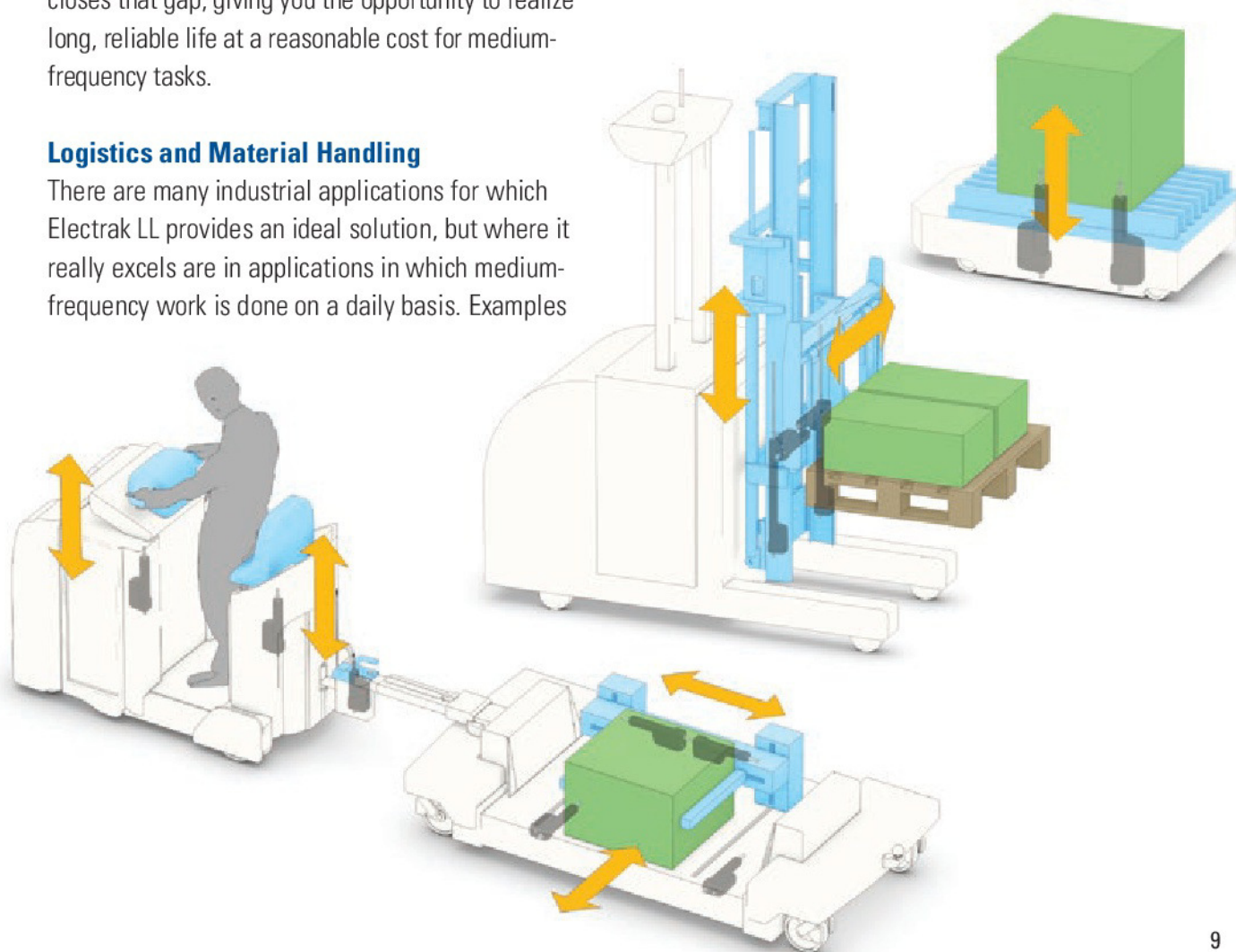



Electrak® LL Technical Features



Electrak LL - The New Long Life Actuator

- Long life expectancy
- High duty cycle
- Constant speed regardless of the load
- Designed and tested to meet the toughest environmental demands
- Complies to railway standards EN 50155, EN 60077 and EN 45545
- Onboard electronics eliminate the need for standalone controls
- Suitable for pneumatic and hydraulic-to-electric application conversions

General Specifications	
Parameter	Electrak LL
Screw type	ball
Nut type	load lock ball nut
Manual override	yes
Anti-rotation	yes
Controlled braking	yes ⁽¹⁾
Static load holding brake	yes
End-of-stroke protection	internal end-of-stroke limit switches
Overload protection	yes
Temperature monitoring	yes
Temperature compensation	yes
Voltage monitoring	yes
Electrical connections ⁽²⁾	cable(s) with flying leads
Compliances	CE, RoHS, EN 50155, EN 60077, EN 45545

(1) The actuator is stopped in a controlled manner using a preset deceleration rate.

(2) There are two cables. The cable(s) enters the actuator via a connector. The replacement of an actuator can be completed by unplugging the old actuator and plugging in the new one.

Optional Features	
Parameter	Electrak LL
Mechanical options	Variety of front and rear adapters
	Alternative adapter orientation

Accessories	
Parameter	Electrak LL
Mechanical	Rod end front adapter
Electrical	External slot-mounted limit switches

Electrak LL Technical Specifications

Mechanical Specifications		
Parameter		Electrak LL
Max. static load ⁽¹⁾	[kN (lbs)]	18 (4050)
Max. dynamic load (Fx)	[kN (lbs)]	4 (899) 6 (1349)
LLxx-B040		
LLxx-B060		
Speed ⁽²⁾	[mm/s (in/s)]	30 (1.18) 15 (0.59)
LLxx-B040		
LLxx-B060		
Min. ordering stroke (S) length	[mm]	100
Max. ordering stroke (S) length	[mm]	500
Ordering stroke length increments	[mm]	50
Operating temperature limits	[°C (F)]	-40 – 85 (-40 – 185)
Full load duty cycle @ 25 °C (77 °F)	[%]	35
End play, maximum	[mm (in)]	1.2 (0.047)
Restraining torque	[Nm (lbs)]	0
Protection class - static		IP66 / IP69K
Protection class - dynamic		IP66
Salt spray resistance	[h]	500

1) Max. static load at fully retracted stroke

2) Speeds are constant regardless of the load

3) Do not use PWM voltage for speed control to avoid damaging the onboard electronics

Weight [kg]

Ordering Stroke (S) [mm]								
100	150	200	250	300	350	400	450	500
6.8	7.2	7.5	7.9	8.2	8.6	8.9	9.3	9.6

Conversion Factors:

Millimeter to inch: 1 mm = 0.03937 in

Kilogram to pound: 1 kg = 2.204623 lbs

Electrical Specifications		
Parameter		Electrak LL
Available input voltage ⁽³⁾	[Vdc]	24
Input voltage tolerance	[Vdc]	16.8 - 32
Current draw @ no load/max. load	[A]	2/10.5 2/8.5
LL24-B040		
LL24-B060		
Motor cable leads cross section	[mm ² (AWG)]	2 (14)
Signal cable leads cross section	[mm ² (AWG)]	0.5 (20)
Standard cable length (Ca1)	[m (in)]	0.3 (11.8)
Cable diameter (Ca2)	[mm (in)]	7.3 (0.29) 6.6 (0.26)
motor cable		
signal cable		
Flying lead length (Ca3)	[mm (in)]	74 (2.9)
Stripped lead length (Ca4)	[mm (in)]	6 (0.25)

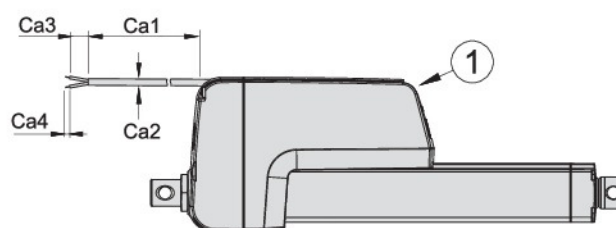

The drawing shows the cables exiting the cable slots at the end of the actuator housing, which is the shipping position. The user can adjust the exit point to be anywhere between the connector (1) in the front of the housing and the end of the cable slots.



How to Order the Electrak® LL

This ordering key provides a quick overview of the product versions available. It is important to consider many application details when selecting a product, including the loads, speeds and control options required, as well as the product environment and necessary accessories.

Ordering Key								
1	2	3	4	5	6	7	8	9
LL24	B040-	0200	LEX	A	S	S	S	D
<p>1. Model and input voltage LL24 = Electrak LL, 24 Vdc</p> <p>2. Screw type, dynamic load capacity B040- = ball screw, 4 kN (899 lbs) B060- = ball screw, 6 kN (1348 lbs)</p> <p>3. Ordering stroke length ⁽¹⁾ 0100 = 100 mm 0150 = 150 mm 0200 = 200 mm 0250 = 250 mm 0300 = 300 mm 0350 = 350 mm 0400 = 400 mm 0450 = 450 mm 0500 = 500 mm</p> <p>4. Electrak Modular Control System version LEX = Electrak Monitoring Package + low-level signal motor switching + external end-off-stroke limit switch inputs</p> <p>5. Harness option A = 0.3 m long cables with flying leads</p>					<p>6. Rear adapter option M = cross hole for 12 mm pin E = cross hole for ½ inch pin N = forked cross hole for 12 mm pin F = forked cross hole for ½ inch pin S = stainless cross hole for 12 mm pin T = stainless forked cross hole for 12 mm pin</p> <p>7. Front adapter option M = cross hole for 12 mm pin E = cross hole for ½ inch pin N = forked cross hole for 12 mm pin F = forked cross hole for ½ inch pin P = metric female thread M12 × 1.75 G = inch female thread 1/2-20 UNF-2B S = stainless cross hole for 12 mm pin Q = stainless metric male thread M16 × 2 R = stainless metric female thread M16 × 2 T = stainless forked cross hole for 12 mm pin</p> <p>8. Adapter orientation S = standard M = 90° turned</p> <p>9. Connector option D = flying leads</p>			
<p>(1) Other stroke lengths available upon request. Please contact customer support.</p>								

Performance Diagrams

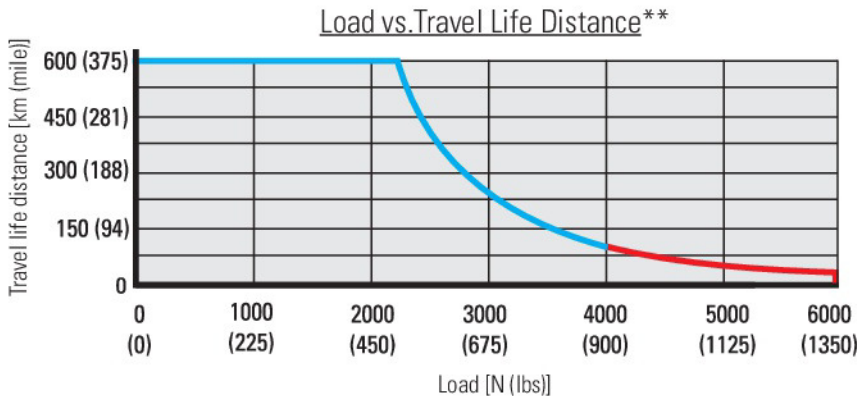
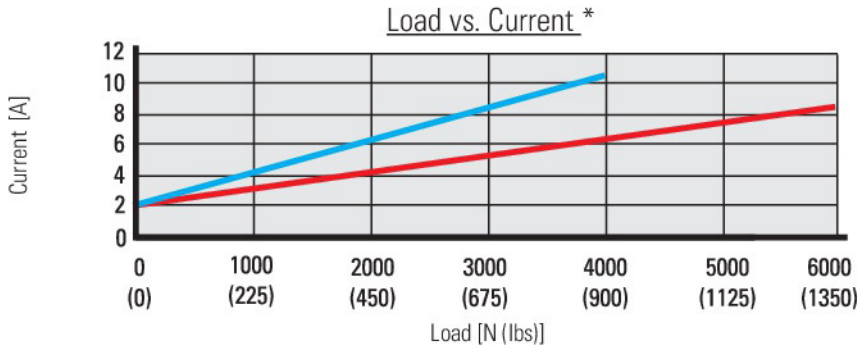
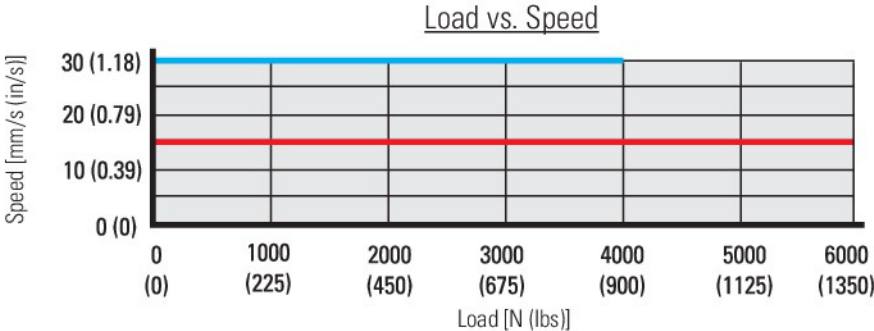

Screw Type and Dynamic Load Capacity

■ ball screw, 4 kN (899 lbs)
 ■ ball screw, 6 kN (1348 lbs)

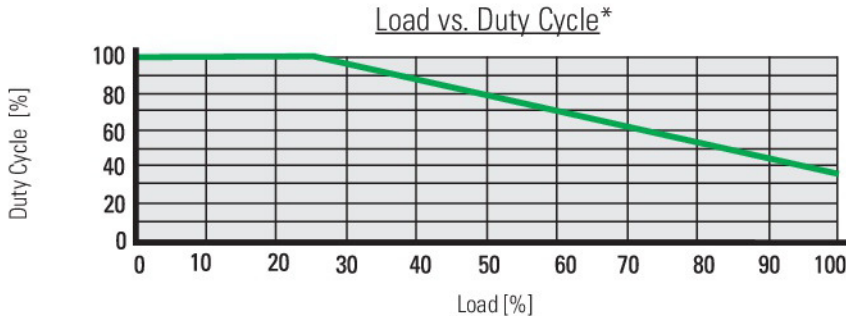

* Curves were generated at an ambient temperature of 25°C (77°F).

** The exact travel life also depends on temperature and other environmental factors. Contact customer support for more information.



Dimensions

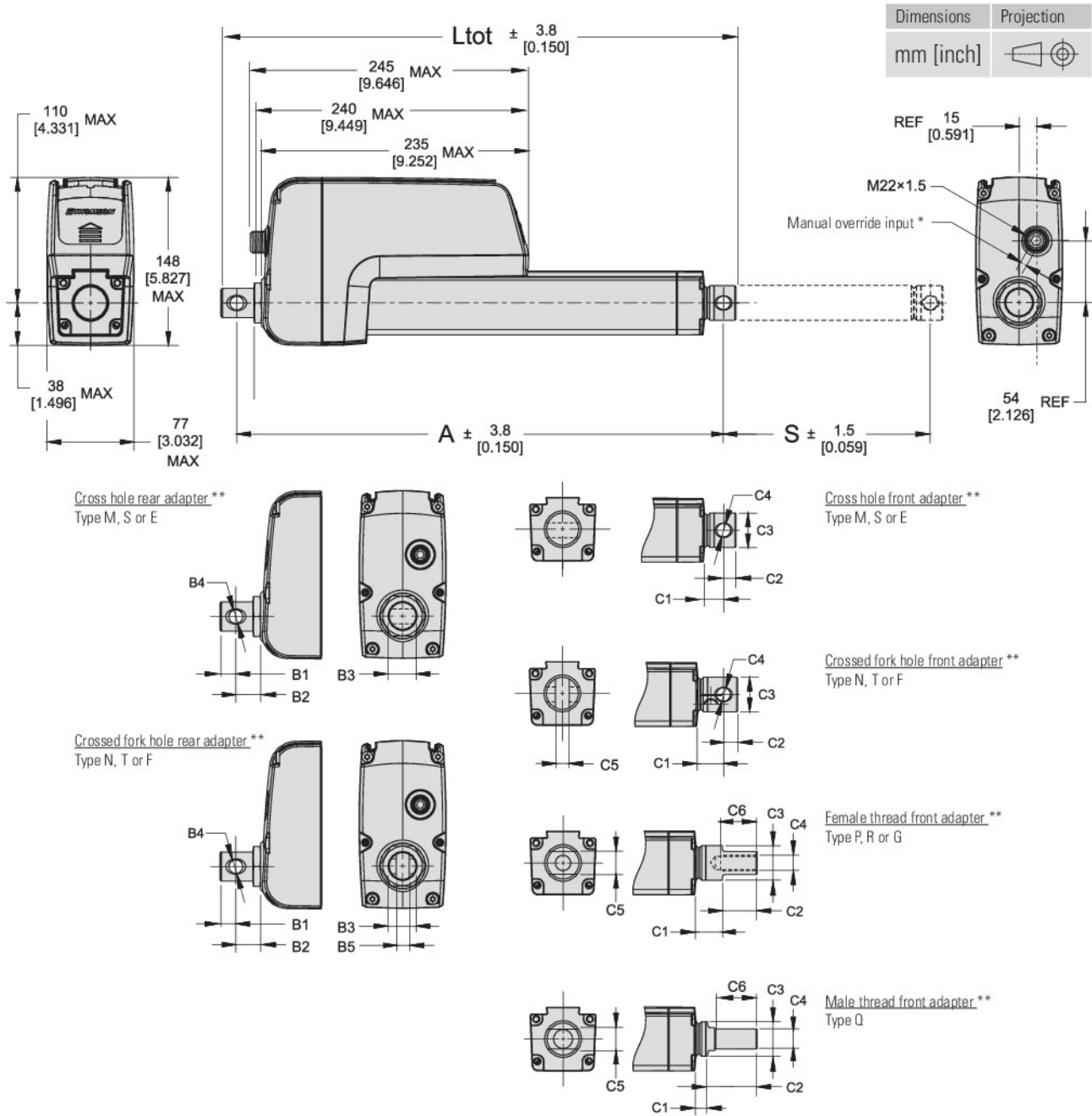

* Manual override input. The input hole is covered with a plastic plug. When removed, a 6 mm female hexagon key can be inserted and used as a crank.
 ** All adapters shown in the standard orientation.

Dimensions

Ordering Stroke, Retracted Length and Total Length Relationships [mm (in)]

Ordering Stroke (S)	Retracted Length (A)	Total Length (Ltot)
100 - 500 (3.937 - 19.685)	$S + 182 (7.165) + B2 + C1$	$A + B1 + C2$

Rear Adapter Dimensions [mm (in)]

	Adapter Type			
	M, S	E	N, T	F
B1	13.4 (0.53)			
B2	21.6 (0.85)			
B3	25.4 (1.0)			
B4	12.2 E9 (0.48)	12.8 (0.506)	12.2 E9 (0.48)	12.8 (0.506)
B5	-	-	8.2 (0.323)	

Front Adapter Dimensions [mm (in)]

	Adapter Type						
	M, S	E	N, T	F	P, R	G	Q
C1	24.0 (0.945)	27.0 (1.063)		24.9 (0.980)		13.2 (0.519)	
C2	10.9 (0.429)	12.9 (0.508)		30 (1.18)		42 (1.654)	
C3	34.93 (1.375)						
C4	12.2 E9 (0.48)	12.8 (0.506)	12.2 E9 (0.48)	12.8 (0.506)	M12 × 1.75	1/2-20 NF-2B	M16 × 2
C5	-	-	8.2 (0.323)		19 (0.748)		
C6	-	-	-	-	35 (1.38)		



Wiring Diagrams and Control Functions

The onboard control used in Electrak® LL is a version of the proven Electrak Modular Control System (EMCS) called LEX. The LEX version is designed to meet the electrical demands in the railway standards.

EMCS Control Version LEX		
Actuator supply voltage	[Vdc]	16.8 - 32
Actuator current draw	[A]	see page 19

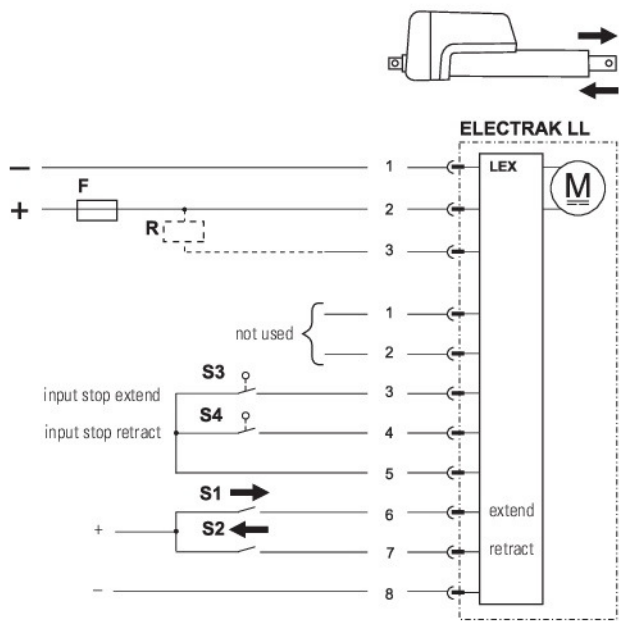

- F Fuse
- R Brake resistor
- S1 Switch extend
- S2 Switch retract
- S3 Limit switch stop extend
- S4 Limit switch stop retract

The actuator movement is controlled by connecting a positive (16.8 – 32 Vdc) to the extend or retract input, and the negative to the common input. There are also external limit switch inputs that stop the actuator from extending or retracting when activated (we recommend using Thomson reed sensors part number 840-9132). In addition, there is a brake resistor output that must be used if there is too much brake energy generated in the

Electronic Monitoring Package Features

Current Monitoring

A critical safety feature that shuts down the actuator on overload and eliminates the need for the traditional mechanical clutch.

Voltage and Temperature Monitoring

Continuous monitoring protects the actuator by preventing motion if outside normal ranges.

Temperature Compensation

Enabling normal operation at lower temperatures without nuisance tripping.

Load Trip Point Calibration

Each Electrak LL actuator is individually calibrated at assembly to ensure a repeatable overload trip point.

Internal End-of-Stroke Limit Switches

Built into each Electrak LL actuator, these switches ensure smooth, repeatable operation and protect both connected equipment and the actuator.

End-of-Stroke Controlled Braking

Enables quick, end-of-stroke stops for more repeatable movements when loads would traditionally cause coasting.

motor due to large helping loads (above 50% of the rated maximum load). The resistor must have a resistance between 2.3 - 3.3 ohms and be able to handle at least 100 W. The power supply and wiring that supply the actuator must be able to handle the motor current for the actuator model and load being used, as well as the inrush current (up to one and a half times the max. continuous current for the max. load being used for up to 150 milliseconds).

Accessories

Limit Switches for Cover Tube Mounting		
Sensor type	solid state	reed switch
Contact type	normally open (N.O.)	
Output type	PNP	contact
Voltage [Vdc/Vac]	10 - 30 / -	5 - 120 / 5 - 120
Max. current [mA]	100	
Hysteresis [mm]	1.5	1.0
Operating temperature [°C]	- 20 to + 70	- 20 to + 70
Lead cross section [mm ²]	3 × 0.14	2 × 0.14
Length (L) [mm]	25.3	30.5
Height (H) [mm]	5.1	5.7
Protection class	IP69K	IP67
LED indicator	yes	
Connection	2 m cable with flying leads	
p/n	840-9131	840-9132

Mounting positions

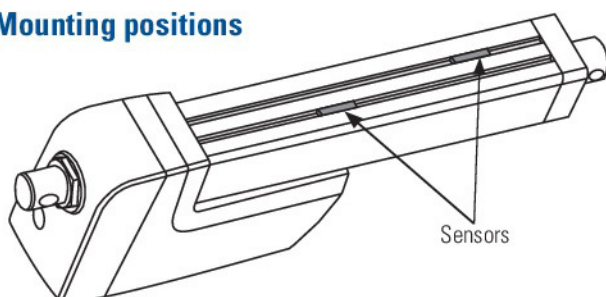

Dimensions [mm]

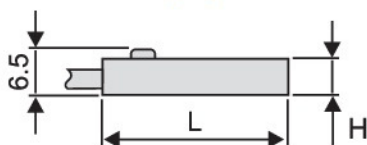

Connection

Solid state

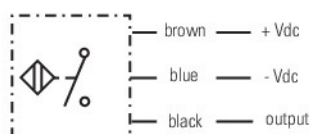

Reed switch

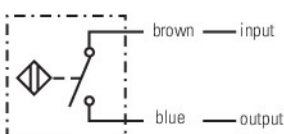

The limit switches are mounted in the cover tube slots and will be switched by a magnet mounted inside of the actuator on the extension tube.

Rod End Front Adapter

Type	metric	inch
Material	Cadmium-plated steel	
Dimensions		
A	12.0 ± 0.1 mm	0.5 in
B	14.3 ± 0.1 mm	0.625 in
C	M12	1/2-20 UNF
p/n	756-9021	756-9007

Dimensions [mm (in)]

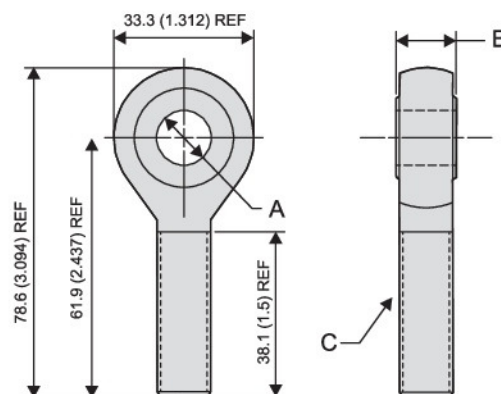

The rod end front adapter comes in a metric or inch version. The metric adapter can be mounted to the front of the extension tube if the actuator is equipped with the metric female thread front adapter option (type P), while the inch adapter requires the inch female thread option (type G).



Frequently Asked Questions

Here are answers to common questions we receive.

What is the typical life of an actuator?

Life is a function of load and stroke length. Please contact customer support for more information.

What are the most common reasons for premature actuator failure?

Side load due to incorrect mounting, shock loading, exceeding the duty cycle and incorrect wiring are the most prominent causes for premature failure.

What are IP ratings?

International Protection Marking (IP) ratings are commonly referenced standards that classify electrical equipment using standard tests to determine resistance to ingress of solid objects (first digit) and liquids (second digit). See the IP Ratings table below.

Is Electrak® LL suitable for tough environments such as washdown or extreme temperatures?

Yes. Electrak LL actuators are designed for washdown and have passed 500 hours of salt spray tests. They can operate in temperatures ranging from -40 to +85°C (-40 to +185°F).

How is the duty cycle determined?

The duty cycle = on time / on time + off time. For example, if Electrak LL is powered for 15 seconds and then off for 45 seconds, the duty cycle for that minute would be 25%. All models are rated to 25% at full load, and an ambient temperature of 25°C (77°F). If load and/or ambient temperature are lower, then the duty cycle can exceed 25%. At higher temperatures, the duty cycle will be lower.

IP Rating (EN60529)		
Code	First Digit Definition	Second Digit Definition
0	No protection.	No protection.
1	Protected against solid objects over 50 mm.	Protected against vertically falling drops of water.
2	Protected against solid objects over 12.5 mm.	Protected against vertically falling drops of water, if the case is disposed up to 15° from vertical.
3	Protected against solid objects over 2.5 mm.	Protected against vertically falling drops of water, if the case is disposed up to 60° from vertical.
4	Protected against solid objects over 1 mm.	Protected against splash water from any direction.
5	Limited protection against dust ingress (no harmful deposits).	Protected against low-pressure water jets from any direction. Limited ingress permitted.
6	Totally dust protected.	Protected against high-pressure water jets from any direction. Limited ingress permitted.
7	–	Protected against short periods of immersion in water.
8	–	Protected against long, durable periods of immersion in water.
9K	–	Protected against close-range, high-pressure and high-temperature spray downs.

Frequently Asked Questions

Is Electrak LL maintenance free?

Yes. Electrak LL never requires lubrication, maintenance or adjustment for wear.

Is it possible for a load to back-drive the extension tube?

No. The ball screw models incorporate a static load holding brake.

What is the difference between a tension and a compression load?

A tension load tries to stretch the actuator, while a compression load tries to compress it. With bi-directional loads, the end play of the actuator extension tube may need to be taken into consideration when using the actuator for positioning tasks.

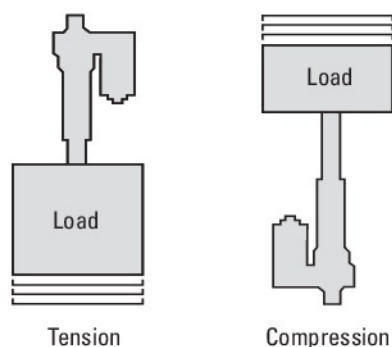

Can Electrak LL be side loaded?

No. A proper design of the application should eliminate any side loads.

What is the range of input voltage an Electrak LL can operate with?

The nominal input voltage is 24 Vdc, but it will accept 16.8 – 32 Vdc. Outside of these limits, the Electronic Monitoring Package will prevent the actuator from operating.

Can the speed of an Electrak LL be adjusted by changing the input voltage?

No. When using direct current from a battery or full wave rectifier that are within the acceptable voltage limits, the Electronic Monitoring Package will keep the actuator at the rated speed. Outside of the limits, the actuator will be switched off. If utilizing Pulse Width Modulation (PWM) controls or drives, the actuator PCB can be damaged and is therefore not recommended.

What is the inrush current?

The inrush current is a short current peak that appears at the start of an actuator as the motor tries to get the load moving. Typically, the inrush current will last between 75 – 150 milliseconds and can be up to three times higher (on a low-level switched actuator 1.5 times higher) than the current for the actuator and load. Batteries have no problem delivering the inrush current, but if using an AC powered power supply, it is important to size it to handle the inrush current.

What special mounting considerations does the Electrak LL require?

There is no restraining torque that needs to be considered as Electrak LL is internally restrained. However, the actuator must be mounted so that there are no side loads acting on the extension tube. It is also important that the manual override input is accessible after the actuator is mounted and that connectors and cables are placed so that they are not damaged during operation.

What is the maximum travel speed?

The speed of an Electrak LL actuator is constant (and therefore always at its "maximum") irrespective of the load as long as it is within the rated load range. If the actuator is overloaded, it will stop.

Aratron

KOMPONENTER I BEVEGELSE

Aratron AS

Bjørnerudveien 17

1266 Oslo

Telefon: 23 19 16 60

E-post: firmapost@aratron.no