

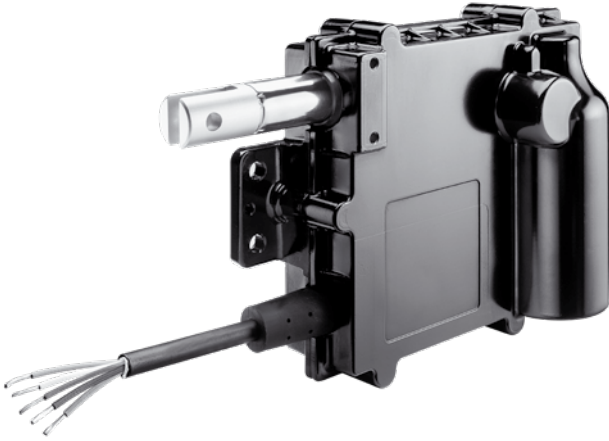

Electrak[®] Throttle – Technical Features



Standard Features

- Designed for industrial applications
- Rugged aluminium housing with IP69K/IP67 ingress protection
- E-coated housing for corrosion resistance
- Minimal maintenance
- Integrated electronic options
- High end features at a low cost
- Integrated mounting holes

General Specifications

Screw type	worm
Nut type	worm
Manual override	no
Anti-rotation	yes
Static load holding brake	no (self-locking)
Safety features	end-of-stroke overload protection mid stroke overload protection motor auto reset thermal switch ⁽¹⁾
Electrical connections	cable with flying leads or Deutsch connector
Compliances	CE

(1) no thermal switch on units with temperature rating E.

Optional Mechanical Features

- Adapter orientation
- Right angle cable exit
- Extended operating temperature range

Optional Electrical Features

- Analog position feedback
- Internal end-of-stroke limit switches
- SAE J1939 CAN bus

Electrak[®] Throttle – Technical Specifications

Mechanical Specifications		
Max. static load ⁽¹⁾ ETxx-084 ⁽²⁾ ETxx-174	[N (lbf)]	90 (20) 260 (60)
Max. dynamic load (Fx) ETxx-084 ⁽²⁾ ETxx-174	[N (lbf)]	45 (10) 130 (30)
Speed @ no load/max. load ETxx-084 ⁽²⁾ ETxx-174	[mm/s (in/s)]	96/83 (3.7/3.3) 48/37(1.9/1.45)
Ordering stroke (S) length	[mm(in)]	50.8 (2)
Retracted length	[mm(in)]	184.7 (7.27)
Operational life	[cycles]	500 000
Operating temperature limits ETxx-xxx-xS ETxx-xxx-xE	[°C (F)]	- 40 – 85 (- 40 – 185) - 40 – 125 (- 40 – 257)
Full load duty cycle @ 25 °C (77 °F)	[%]	50
End play, maximum	[mm (in)]	1.5 (0.06)
Restraining torque	[Nm (lbf-in)]	0
Protection class - static		IP69K, IP65
Weight	[kg (lbf)]	1.11 (2.5)
Salt spray resistance	[h]	500

(1) Max. static load at fully retracted stroke.

(2) The ETxx-084 (high speed version) can only be ordered in combination with operating temperature rating E.

Electrical Specifications		
Available input voltages	[Vdc]	12, 24
Input voltage tolerance	[%]	± 10
Current draw @ no load/max. load ⁽¹⁾ ET12 (12 Vdc input voltage) ET24 (24 Vdc input voltage)	[A]	1.5/4 0.75/2
Motor cable length	[m (in)]	165 (6.5)
Motor cable diameter	[mm (in)]	11.5 (0.45)
Motor cable leads cross section	[mm ² (AWG)]	1 (18)

(1) Max. current draw ratings do not include motor inrush current. Typical inrush current values are 12 A at 12 VDC and 6 A at 24 VDC.



Electrak[®] Throttle – Dimensions

Dimensions	Projection
mm [inch]	

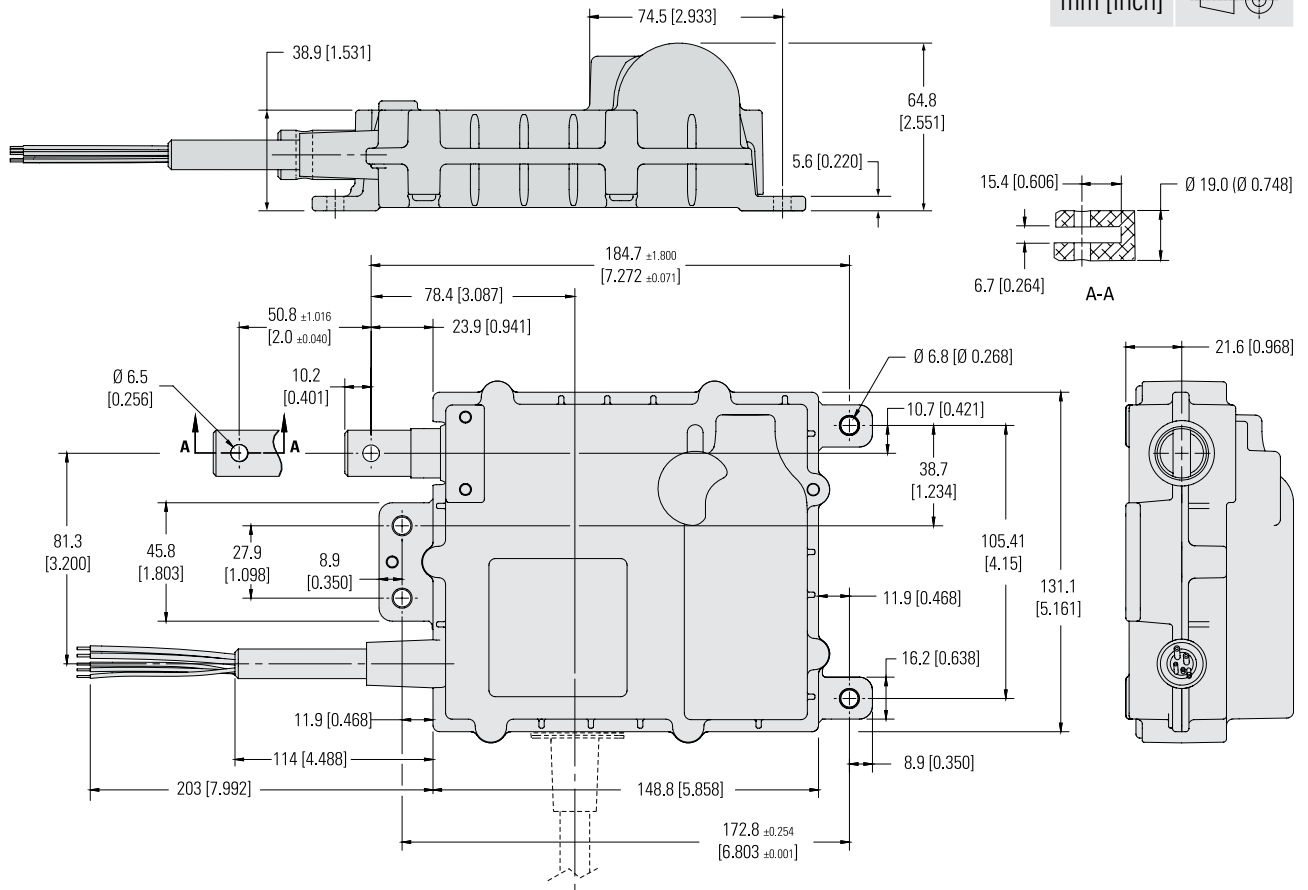

Electrak[®] Throttle – Performance Diagrams

Speed and Current vs. Load

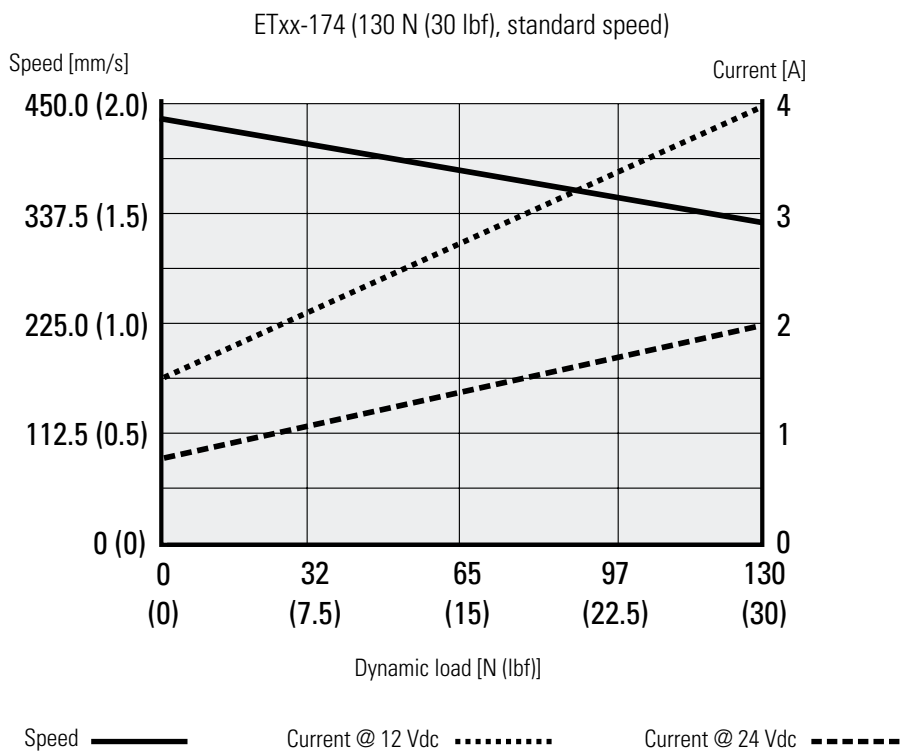
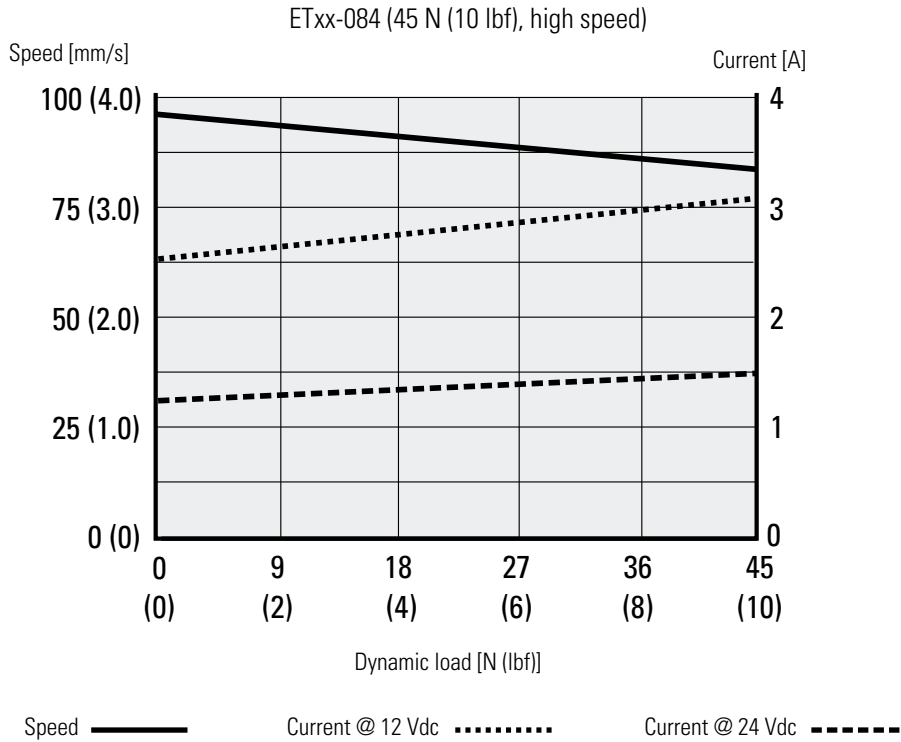

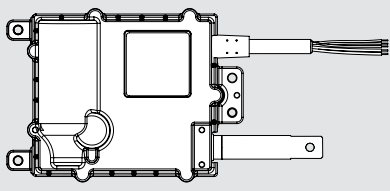
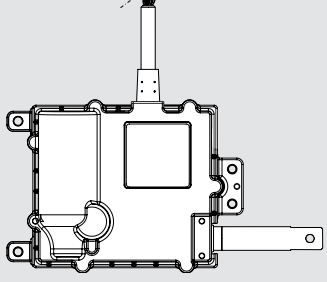
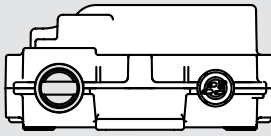
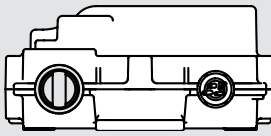

Electrak® Throttle – Ordering Key

Ordering Key						
1	2	3	4	5	6	7
ET12-	174-	S	S	NP	1	S
<p>1. Model and input voltage ET12 - = Electrak® Throttle, 12 Vdc ET24 - = Electrak® Throttle, 24 Vdc</p> <p>2. Max. dynamic load and speed version 084 - = 45 N (10 lbf), high speed ⁽¹⁾ 174 - = 130 N (30 lbf), standard speed</p> <p>3. Harness orientation S = parallel to adapter R = rotated 90° in housing</p> <div style="display: flex; align-items: center;"> <div style="margin-right: 10px;">S</div>  </div> <div style="display: flex; align-items: center; margin-top: 10px;"> <div style="margin-right: 10px;">R</div>  </div>	<p>4. Temperature rating S = standard: -40 (-40) to +85 (+185) °C (F) E = high temperature: -40 (-40) to +125 (+257) °C (F)</p> <p>5. Control option NP = analog position feedback sensor FN = end-of-stroke limit switches FP = analog position feedback and end-of-stroke limit switches CN = SAE J1939 CAN bus</p> <p>6. Connector option 1 = flying leads 2 = Deutsch DTM04-6P connector</p> <p>7. Adapter option S = standard adapter orientation M = adapter rotated 90°</p> <div style="display: flex; align-items: center;"> <div style="margin-right: 10px;">S</div>  </div> <div style="display: flex; align-items: center; margin-top: 10px;"> <div style="margin-right: 10px;">M</div>  </div>					
<p>(1) Can only be ordered with high temperature rating (code E in position 4). Note that there is no thermal switch to protect the motor on the high temperature rated models.</p>						

Electrak[®] Throttle – Electrical Connections

Option End-of-Stroke Limit Switches		
Actuator supply voltage	[Vdc]	
ET12		12
ET24		24

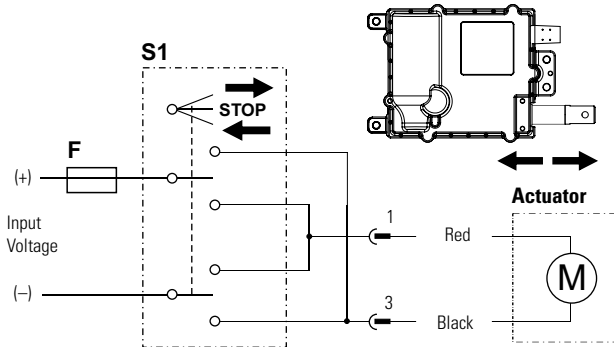

- M Actuator motor
- S1 Double pole double throw (DPDT) switch
- F Fuse

Connect black lead (connector pin 3) to positive and red lead (pin 1) to negative to extend the actuator. Change polarity to retract the actuator. When reaching the ends of stroke, the internal limit switches automatically will stop motion. A clutch is included as a safety feature to stop the motion in case of mid stroke overload.

Option Analog Feedback		
Actuator supply voltage	[Vdc]	
ET12		12
ET24		24
Analog feedback type		non-contact
Analog feedback input voltage, max.	[Vdc in]	32
Analog feedback output voltage	[Vdc out]	
fully retracted		< 5 % of VDC in
fully extended		> 75 % of VDC in
Analog feedback output current, max.	[mA]	1
Analog feedback output linearity	[%]	± 1

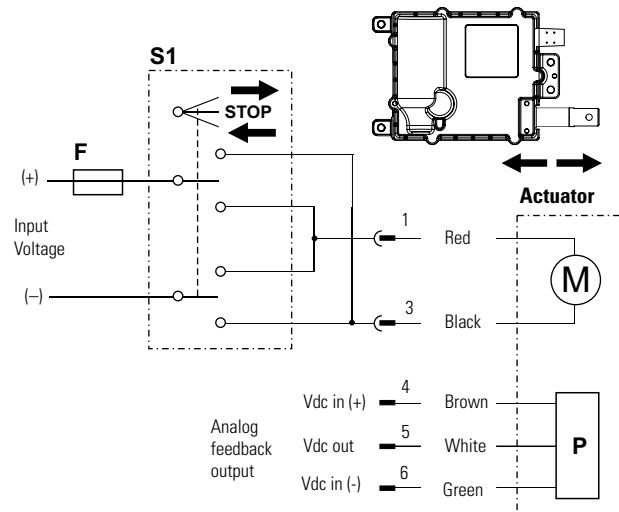

- M Actuator motor
- S1 Double pole double throw (DPDT) switch
- F Fuse
- P Analog feedback device

Connect black lead (connector pin 3) to positive and red lead (pin 1) to negative to extend the actuator. Change polarity to retract the actuator. If the actuator should reach the mechanical end of stroke, the built in clutch will stop the motion. The clutch, however, is a safety feature and should not be used as end of stroke control during normal operation.

The analog feedback device is supplied between brown lead (connector pin 4) and green lead (pin 6), while the output signal is on white lead (pin 5).



Electrak[®] Throttle – Electrical Connections

Option Analog Feedback + End-of-Stroke Limit Switches

Actuator supply voltage	[Vdc]	
ET12		9 - 16
ET24		18 - 32
Analog feedback type		non contact
Analog feedback input voltage, max.	[Vdc in]	32
Analog feedback output voltage	[Vdc out]	
fully retracted		< 5 % of VDC in
fully extended		> 75 % of VDC in
Analog feedback output current, max.	[mA]	1
Analog feedback output linearity	[%]	± 1

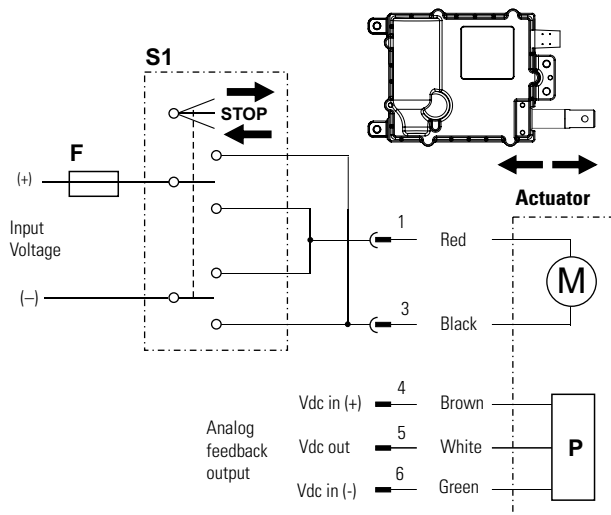

- M Actuator motor
- S1 Double pole double throw (DPDT) switch
- F Fuse
- P Analog feedback device

Connect black lead (connector pin 3) to positive and red lead (pin 1) to negative to extend the actuator. Change polarity to retract the actuator. When reaching the ends of stroke, the internal limit switches automatically will stop motion. A clutch is included as a safety feature to stop the motion in case of mid stroke overload.

The analog feedback device is supplied between brown lead (connector pin 4) and green lead (pin 6), while the output signal is on white lead (pin 5).

Option SAE J1939 CAN bus

Actuator supply voltage	[Vdc]	
ET12		12
ET24		24
CAN bus signal information		see user manual

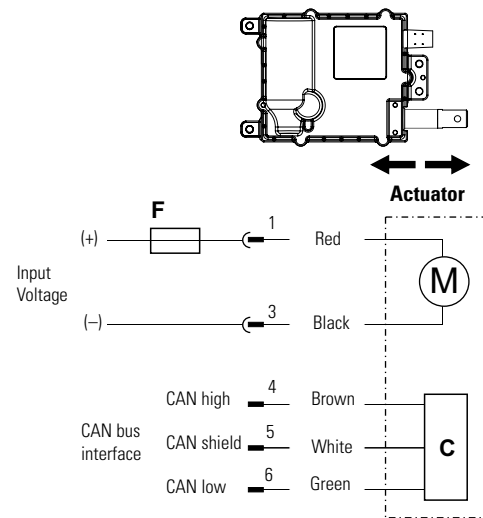

- M Actuator motor
- S1 Double pole double throw (DPDT) switch
- F Fuse
- C CAN bus device

Connect red lead to (connector pin 1) to positive and black (pin 3) to negative to power up the actuator. A clutch is included as a safety feature to stop the motion in case of mechanical overload.

The actuator is controlled via the CAN bus interface on brown lead (connector pin 4), white lead (pin 5) and green lead (pin 6).