

Materials / Surfaces:

Input flange: Stainless steel 1.4404 / electropolished
 Housing: Stainless steel 1.4404 / electropolished
 Output flange: Stainless steel 1.4404 / electropolished
 Feather key: Stainless steel 1.4401 / bare
 Output shaft: Stainless steel 1.4404 / bare

Hints:

Please pay attention to the operating and mounting instructions.
 Subject to modifications.

Variables on the drawing are dependent upon the motor.
 The given dimensions are exemplary.

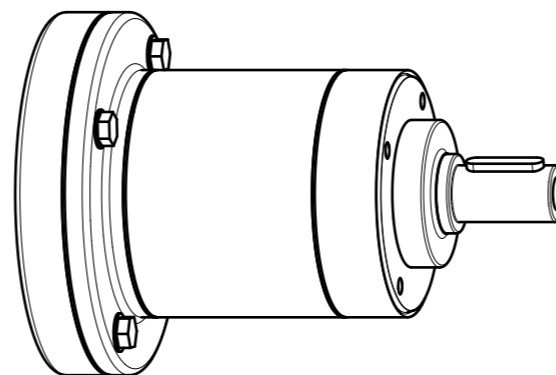

----- Electropolished

	Scale: 2:5	DIN A3	ISO
	Revision status: A from: 11/2021		
General tolerance DIN ISO 2768-cl	HLAE110-bii-SFSA3SF-Z(D20) /(L20)/(D21)/(D22)/B14/(G3)		
Neugart GmbH Keltenstr. 16 D-77971 Kippenheim			Sheet 1/2

General gearbox data	Character	Unit	
Planetary gearbox - gearing type	-	-	Straight teeth
Rotation direction	-	-	Input and output in the same direction
Number of stages	p	-	2-stage
Output shaft bearing	-	-	Deep groove ball bearing
Service life (L10h)	t_L	h	30.000
Max. operating temperature	T_{min} / T_{max}	°C	-25 / +90
Protection class	-	-	IP 69K
Lubrication (lifetime lubrication)	-	-	Food grade lubrication (Klübersynth UH1 14-222)
Installation position	-	-	Any
Max. bending moment based on the gearbox input flange (for motor weight) (1)	M_b	Nm	40
Motor shaft concentricity / Coaxiality and axial runout Motor flange	-	mm	0,04 / 0,08 (Measuring methods according to DIN EN 50347)
Required motor shaft tolerance	-	-	j6; k6
Min. permissible motor shaft length	$L_{20 min}$	mm	27,5
Reference operating mode	-	-	S1
Reference operating factor	K_A	-	1
Reference speed	n_2	rpm	100
Reference ambient temperature	T_{Amb}	°C	20
Radial force for output bearing based on shaft center after L10h=20,000h with Fa=0N	$F_r 20.000h$	N	1450
Axial force for output bearing based on gearbox axis after L10h=20,000h with Fr=0N	$F_a 20.000h$	N	2500
Radial force for output bearing based on shaft center after L10h=30,000h with Fa=0N	$F_r 30.000h$	N	1250
Axial force for output bearing based on gearbox axis after L10h=30,000h with Fr=0N	$F_a 30.000h$	N	2000
Maximum radial force based on shaft center and T2=0Nm	$F_r Max$	N	5000
Maximum axial force based on gearbox axis and T2=0Nm	$F_a Max$	N	3800

Ratio-dependent gearbox data	Character	Unit										
Ratio	bii	-	9	12	15	16	20	25	32	40	64	100
Nominal output torque No alternating torque (2)	T_{2N}	Nm	157	171	171	171	171	171	171	171	120	95
Nominal output torque Alternating torque permitted for 10,000,000 load changes (3)	$T_{2N 10Mio}$	Nm	68	68	68	68	68	68	68	68	68	68
Nominal output torque Alternating torque permitted for 100,000,000 load changes (3)	$T_{2N 100Mio}$	Nm	54	54	54	54	54	54	54	54	54	54
Max. output torque for 30,000 output shaft rotations (2)	T_{2max}	Nm	251	274	274	274	274	274	274	274	192	152
Emergency stop torque permitted 1000 times	T_{2stop}	Nm	314	342	342	342	342	342	342	342	240	190
Average idle torque for $n_1=3,000$ rpm and 20 °C gearbox temperature	T_0	Nm	0,95	0,85	0,8	0,85	0,7	0,65	0,5	0,5	0,5	0,45
Average thermal input speed at 50% T2N, S1, and T_Amb Operating temperature may not be exceeded!	$n_{1N 50\%}$	rpm	2400	2450	2550	2650	2850	2950	3000	3000	3000	3000
Average thermal input speed at 100% T2N, S1, and T_Amb Operating temperature may not be exceeded!	$n_{1N 100\%}$	rpm	1950	2050	2200	2300	2500	2650	2900	3000	3000	3000
Max. mechanical input speed Operating temperature may not be exceeded!	$n_{1 Limit}$	rpm	6500	6500	6500	6500	6500	6500	6500	6500	6500	6500
Torsional backlash based on output shaft	j_t	arcmin	< 9	< 9	< 9	< 9	< 9	< 9	< 9	< 9	< 9	< 9
Torsional stiffness based on output shaft	c_g	Nm/arcmin	17,5	19	18,5	19	19	18,5	19	18,5	16,6	13,5
Efficiency at T2N, gearbox temperature 70 °C and $n_1=1,000$ rpm	η	%	96	96	96	96	95	95	94	93	89	83
Running noise at $n_1=3,000$ rpm without load at a distance of 1m	Q_g	dB(A)	65	65	65	65	65	65	65	65	65	65
Gearbox weight	m_G	kg	9,8	9,8	9,8	9,8	9,8	9,8	9,8	9,9	9,9	10,1
Mass moment of inertia based on clamping system diameter input	J	kgcm ²	2,62	2,411	2,392	1,936	1,764	1,757	1,612	1,609	1,606	1,569

$$(1) \text{ Max. motor weight* in kg} = \frac{0,2 \times M_b}{\text{motor length in m}}$$

- * with symmetrically distributed motor weight
- * with horizontal and stationary mounting

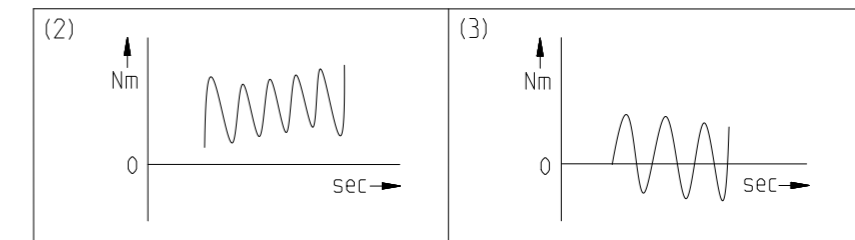

Subject to modifications.



HLAE110-bii-SFSA3SF-Z(D20)
/(L20)/(D21)/(D22)/B14/(G3)

Sheet 2/2

Revision status: A from: 11/2021