

**Materials / Surfaces:**

Input flange: Stainless steel 1.4404 / electropolished  
 Housing: Stainless steel 1.4404 / electropolished  
 Output flange: Stainless steel 1.4404 / electropolished  
 Feather key: Stainless steel 1.4401 / bare  
 Output shaft: Stainless steel 1.4404 / bare

**Hints:**

Please pay attention to the operating and mounting instructions.  
 Subject to modifications.

Variables on the drawing are dependent upon the motor.  
 The given dimensions are exemplary.

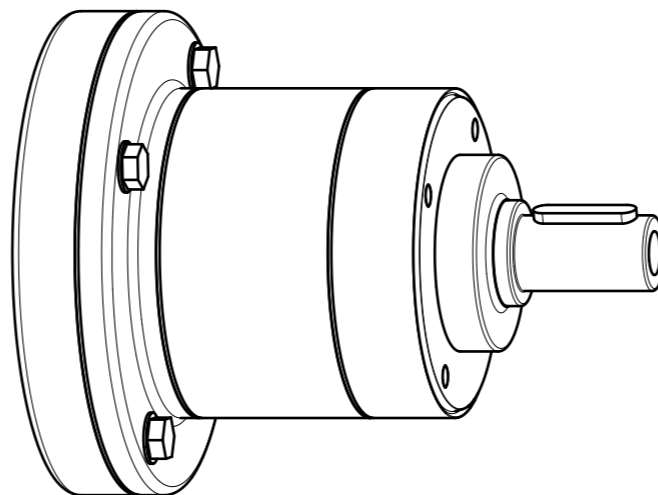

----- Electropolished

	Scale: 1:2	DIN A3	ISO
	Revision status: A from: 11/2021		
General tolerance DIN ISO 2768-cL	HLAE110-aii-SFSA3SF-Z(D20) /(L20)/(D21)/(D22)/B14/(G3)		
Neugart GmbH Keltenstr. 16 D-77971 Kippenheim			Sheet 1/2

General gearbox data	Character	Unit	
Planetary gearbox - gearing type	-	-	Straight teeth
Rotation direction	-	-	Input and output in the same direction
Number of stages	p	-	1-stage
Output shaft bearing	-	-	Deep groove ball bearing
Service life (L10h)	$t_L$	h	30.000
Max. operating temperature	$T_{min} / T_{max}$	°C	-25 / +90
Protection class	-	-	IP 69K
Lubrication (lifetime lubrication)	-	-	Food grade lubrication (Klübersynth UH1 14-222)
Installation position	-	-	Any
Max. bending moment based on the gearbox input flange (for motor weight) (1)	$M_b$	Nm	40
Motor shaft concentricity / Coaxiality and axial runout Motor flange	-	mm	0,04 / 0,08 (Measuring methods according to DIN EN 50347)
Required motor shaft tolerance	-	-	j6; k6
Min. permissible motor shaft length	$L_{20 min}$	mm	27,5
Reference operating mode	-	-	S1
Reference operating factor	$K_A$	-	1
Reference speed	$n_2$	rpm	100
Reference ambient temperature	$T_{Amb}$	°C	20
Radial force for output bearing based on shaft center after L10h=20,000h with Fa=0N	$F_r 20.000h$	N	1450
Axial force for output bearing based on gearbox axis after L10h=20,000h with Fr=0N	$F_a 20.000h$	N	2500
Radial force for output bearing based on shaft center after L10h=30,000h with Fa=0N	$F_r 30.000h$	N	1250
Axial force for output bearing based on gearbox axis after L10h=30,000h with Fr=0N	$F_a 30.000h$	N	2000
Maximum radial force based on shaft center and T2=0Nm	$F_r Max$	N	5000
Maximum axial force based on gearbox axis and T2=0Nm	$F_a Max$	N	3800

$$(1) \text{ Max. motor weight* in kg} = \frac{0,2 \times M_b}{\text{motor length in m}}$$

- \* with symmetrically distributed motor weight
- \* with horizontal and stationary mounting

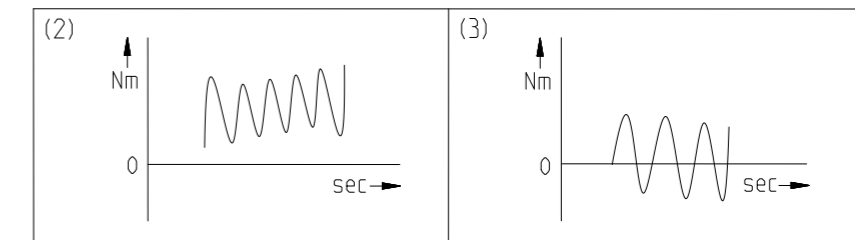

Ratio-dependent gearbox data	Character	Unit						
Ratio	aii	-	3	4	5	7	8	10
Nominal output torque No alternating torque (2)	$T_{2N}$	Nm	115	155	171	135	120	95
Nominal output torque Alternating torque permitted for 10,000,000 load changes (3)	$T_{2N 10Mio}$	Nm	68	68	68	68	68	68
Nominal output torque Alternating torque permitted for 100,000,000 load changes (3)	$T_{2N 100Mio}$	Nm	54	54	54	54	54	54
Max. output torque for 30,000 output shaft rotations (2)	$T_{2max}$	Nm	184	248	274	216	192	152
Emergency stop torque permitted 1000 times	$T_{2Stop}$	Nm	230	310	342	270	240	190
Average idle torque for $n_1=3,000$ rpm and 20 °C gearbox temperature	$T_0$	Nm	1,85	1,5	1,1	0,8	0,7	0,6
Average thermal input speed at 50% T2N, S1, and T_Amb Operating temperature may not be exceeded!	$n_{1N 50\%}$	rpm	2000	2000	2150	2600	2800	3000
Average thermal input speed at 100% T2N, S1, and T_Amb Operating temperature may not be exceeded!	$n_{1N 100\%}$	rpm	1550	1500	1550	2100	2350	2700
Max. mechanical input speed Operating temperature may not be exceeded!	$n_1 Limit$	rpm	6500	6500	6500	6500	6500	6500
Torsional backlash based on output shaft	$j_t$	arcmin	< 7	< 7	< 7	< 7	< 7	< 7
Torsional stiffness based on output shaft	$c_g$	Nm/arcmin	16,4	18	18,5	16,4	16,2	14,7
Efficiency at T2N, gearbox temperature 70 °C and $n_1=1,000$ rpm	$\eta$	%	98	98	98	97	97	96
Running noise at $n_1=3,000$ rpm without load at a distance of 1m	$Q_g$	dB(A)	65	65	65	65	65	65
Gearbox weight	$m_G$	kg	8,4	8,4	8,5	8,5	8,5	8,5
Mass moment of inertia based on clamping system diameter input	J	kgcm <sup>2</sup>	2,63	1,975	1,789	1,652	1,621	1,579

Subject to modifications.



HLAE110-aii-SFSA3SF-Z(D20)  
/(L20)/(D21)/(D22)/B14/(G3)

Sheet 2/2

Revision status: A from: 11/2021