

Crossed Roller Bearings

CRBD

4.4 CRBD

Series with split outer ring and mounting flange.

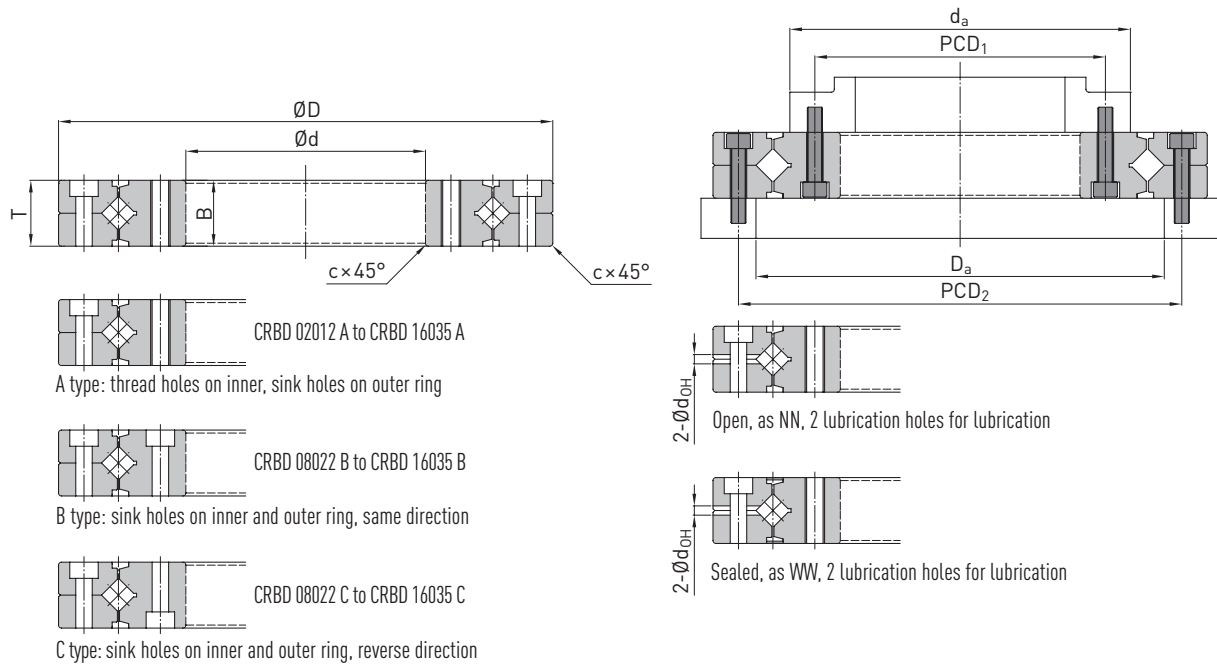

Table 4.4 CRBD specifications

Article number	Dimensions [mm]					Inst. dim. [mm]		Load ratings [kN]				Mounting holes [mm]				Max. $T_d^{1)}$ [Nm] ²⁾	Max. speed [rpm]		Mass [kg]
	d ¹⁾	D ¹⁾	B, T ¹⁾	c _{min}	d _{OH} ¹⁾	d _a	D _a	C _{dyn} ¹⁾		C ₀ ¹⁾		Inner rings		Outer rings			Grease	Oil	
								Rad.	Ax.	Rad.	Ax.	PCD ₁	Mounting holes	PCD ₂	Mounting holes				
CRBD 02012 A ³⁾	20	70	12	0.6	3	35	47	8.3	18	9.2	20.8	28	6×M3	57	6×Ø6.5×3.3U Ø3.4	0.075	1,470	1,970	0.30
CRBD 03515 A	35	95	15	0.6	3	57	73	18.9	42	23.4	53.0	45	8×M4	83	8×Ø8×4.4U Ø4.5	0.25	930	1,250	0.65
CRBD 05515 A	55	120	15	0.6	3	77	92	21.7	48	30.6	69.0	65	8×M5	105	8×Ø9.5×5.4U Ø5.5	0.4	710	950	0.97
CRBD 08022 A	80	165	22	1.0	3	117	132	40.4	90	63.6	144.0	97	10×M5	148	10×Ø9.5×5.4U Ø5.5	1.0	480	640	2.56
CRBD 08022 B													10×Ø9.5×5.4U Ø5.5						
CRBD 08022 C													10×Ø9.5×5.4U Ø5.5						
CRBD 09025 A	90	210	25	1.5	3	139	157	46.0	102	80.2	182.0	112	12×M8	187	12×Ø14×8.6U Ø9	1.5	400	530	5.04
CRBD 09025 B													12×Ø14×8.6U Ø9						
CRBD 09025 C													12×Ø14×8.6U Ø9						
CRBD 11528 A	115	240	28	1.5	3	168	188	73.1	162	131.9	300.0	139	12×M8	217	12×Ø14×8.6U Ø9	2.7	330	440	6.76
CRBD 11528 B													12×Ø14×8.6U Ø9						
CRBD 11528 C													12×Ø14×8.6U Ø9						
CRBD 16035 A	160	295	35	2.0	6	218	238	102.0	226	192.3	437.0	184	12×M10	270	12×Ø17.5×10.8U Ø11	4.8	260	340	11.98
CRBD 16035 B													12×Ø17.5×10.8U Ø11						
CRBD 16035 C													12×Ø17.5×10.8U Ø11						

¹⁾ d = Inner diameter; D = Outer diameter; d_{OH} = Lubrication hole diameter; B, T = width; T_d = Idle torque

C_{dyn} = Dynamic load rating; C = Static load rating

²⁾ Measured at 30 rpm with grease filling (G05)

³⁾ CRBD 02012 A only available in C8

Note: The load ratings correspond to the standard ISO76/ISO281