

**Materials / Surfaces:**

Input flange: Aluminum / untreated  
 Angle housing: Aluminum / Anodized (black)  
 Output flange: Steel / untreated

**Hints:**

Please pay attention to the operating and mounting instructions.  
 Subject to modifications.

Variables on the drawing are dependent upon the motor.  
 The given dimensions are exemplary.

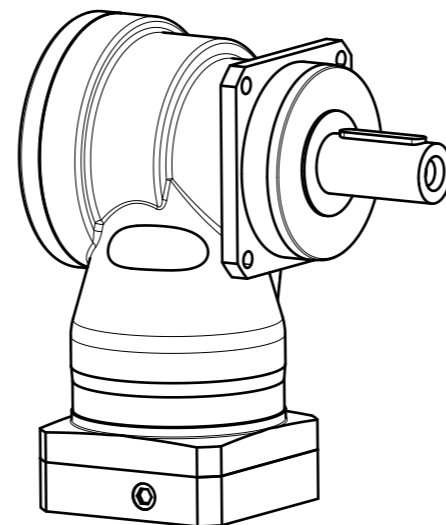

	Scale: 2:5	DIN A3	ISO
	Revision status: P from: 08/2023		
	Changed revision status: 0 from: 09/2022		
General tolerance DIN ISO 2768-cl	WPLN142-aii-SSSA3AG-Y(D20) /(L20)/(D21)/(D22)/B5/(G3)		
Neugart GmbH Keltenstr. 16 D-77971 Kippenheim			Sheet 1/2

General gearbox data	Character	Unit	
Bevel gearbox - gearing type	-	-	Hypoid teeth
Rotation direction	-	-	Input and output in opposite directions
Number of stages	p	-	1-stage
Output shaft bearing	-	-	Tapered roller bearing
Service life (L10h)	$t_L$	h	20.000
Max. operating temperature	$T_{min} / T_{max}$	°C	-25 / +90
Protection class	-	-	IP 65
Lubrication (lifetime lubrication)	-	-	Standard lubrication (Castrol Optigear Synthetic 800)
Installation position	-	-	Any
Max. bending moment based on the gearbox input flange (for motor weight) (1)	$M_b$	Nm	120
Motor shaft concentricity / Coaxiality and axial runout Motor flange	-	-	0,015 / 0,03 (Measuring methods according to DIN EN 50347)
Required motor shaft tolerance	-	-	j6; k6
Min. permissible motor shaft length	$L_{20min}$	mm	27
Reference operating mode	-	-	S1
Reference operating factor	$K_A$	-	1
Reference speed	$n_2$	rpm	100
Reference ambient temperature	$T_{Amb}$	°C	20
Radial force for output bearing based on shaft center after L10h=20.000h with Fa=0N	$F_r 20.000h$	N	12500
Axial force for output bearing based on gearbox axis after L10h=20.000h with Fr=0N	$F_a 20.000h$	N	14500
Radial force for output bearing based on shaft center after L10h=30.000h with Fa=0N	$F_r 30.000h$	N	10900
Axial force for output bearing based on gearbox axis after L10h=30.000h with Fr=0N	$F_a 30.000h$	N	12000
Maximum radial force based on shaft center and T2=0Nm	$F_r Max$	N	12500
Maximum axial force based on gearbox axis and T2=0Nm	$F_a Max$	N	14500

$$(1) \text{ Max. motor weight* in kg} = \frac{0,2 \times M_b}{\text{motor length in m}}$$

\* with symmetrically distributed motor weight  
\* with horizontal and stationary mounting

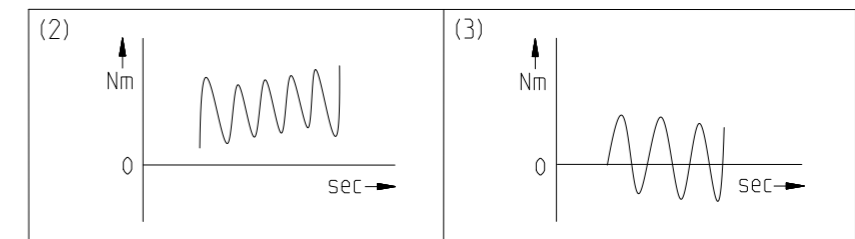

Ratio-dependent gearbox data	Character	Unit					
Ratio	aii	-	4	5	7	8	10
Nominal output torque No alternating torque (2)	$T_{2N}$	Nm	320	280	189	180	160
Nominal output torque Alternating torque permitted for 10.000.000 load changes (3)	$T_{2N 10Mio}$	Nm	320	280	189	180	160
Nominal output torque Alternating torque permitted for 100.000.000 load changes (3)	$T_{2N 100Mio}$	Nm	319	280	189	180	160
Max. output torque for 30.000 output shaft rotations (2)	$T_{2max}$	Nm	512	448	302	288	256
Emergency stop torque permitted 1000 times	$T_{2stop}$	Nm	800	800	700	700	700
Average idle torque for $n_1=3.000$ rpm and 20 °C gearbox temperature	$T_0$	Nm	16	16	16	16	16
Average thermal input speed at 50% $T_{2N}$ , S1, and $T_{Amb}$ Operating temperature may not be exceeded!	$n_{1N 50\%}$	rpm	950	1000	1200	1200	1300
Average thermal input speed at 100% $T_{2N}$ , S1, and $T_{Amb}$ Operating temperature may not be exceeded!	$n_{1N 100\%}$	rpm	800	850	1100	1100	1200
Max. mechanical input speed Operating temperature may not be exceeded!	$n_{1 Limit}$	rpm	8000	8000	8000	8000	8000
Torsional backlash based on output shaft	$j_t$	arcmin	< 5	< 5	< 5	< 5	< 5
Torsional stiffness based on output shaft	$c_g$	Nm/arcmin	34	32,5	30	28	25,5
Efficiency at $T_{2N}$ , gearbox temperature 70 °C and $n_1=1.000$ rpm	$\eta$	%	95	94	90	90	86
Running noise at $n_1=3.000$ rpm without load at a distance of 1m	$Q_g$	dB(A)	70	70	70	70	70
Gearbox weight	$m_G$	kg	25,9	26,3	26,2	26,5	26,3
Mass moment of inertia based on clamping system diameter input	J	kgcm <sup>2</sup>	20.883	18.307	15.472	15.705	15.090

Subject to modifications.



WPLN142-aii-SSSA3AG-Y(D20)  
/(L20)/(D21)/(D22)/B5/(G3)

Sheet 2/2

Revision status: P from: 08/2023