

Materials / Surfaces:

Input flange: Aluminum / untreated
 Angle housing: Aluminum / Anodized (black)
 Intermediate flange: Aluminum / untreated
 Enclosure planetary stage: Steel / heat-treated and post-oxidized (black)
 Output flange: Steel / untreated

Hints:

Please pay attention to the operating and mounting instructions.
 Subject to modifications.

Variables on the drawing are dependent upon the motor.
 The given dimensions are exemplary.

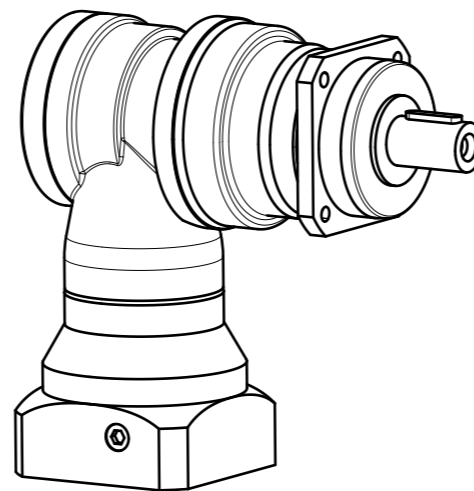

	Scale: 3:5	DIN A3	ISO
	Revision status: P from: 08/2023		
	Changed revision status: 0 from: 09/2022		
General tolerance DIN ISO 2768-cl	WPLN090-bii-SSSA3AE-Z(D20) /(L20)/(D21)/(D22)/B5/(G3)		
Neugart GmbH Keltenstr. 16 D-77971 Kippenheim	Sheet 1/2		

General gearbox data	Character	Unit	
Bevel gearbox - gearing type	-	-	Hypoid teeth
Planetary gearbox - gearing type	-	-	Straight teeth
Rotation direction	-	-	Input and output in opposite directions
Number of stages	p	-	2-stage
Output shaft bearing	-	-	Tapered roller bearing
Service life (L10h)	t_L	h	20.000
Max. operating temperature	T_{min} / T_{max}	°C	-25 / +90
Protection class	-	-	IP 65
Lubrication (lifetime lubrication)	-	-	Standard lubrication (Castrol Optigear Synthetic 800)
Installation position	-	-	Any
Max. bending moment based on the gearbox input flange (for motor weight) (1)	M_b	Nm	12
Motor shaft concentricity / Coaxiality and axial runout Motor flange	-	-	0,015 / 0,03 (Measuring methods according to DIN EN 50347)
Required motor shaft tolerance	-	-	j6; k6
Min. permissible motor shaft length	L_{20min}	mm	29
Reference operating mode	-	-	S1
Reference operating factor	K_A	-	1
Reference speed	n_2	rpm	100
Reference ambient temperature	T_{Amb}	°C	20
Radial force for output bearing based on shaft center after L10h=20.000h with Fa=0N	$F_r 20.000h$	N	5500
Axial force for output bearing based on gearbox axis after L10h=20.000h with Fr=0N	$F_a 20.000h$	N	6400
Radial force for output bearing based on shaft center after L10h=30.000h with Fa=0N	$F_r 30.000h$	N	4800
Axial force for output bearing based on gearbox axis after L10h=30.000h with Fr=0N	$F_a 30.000h$	N	5700
Maximum radial force based on shaft center and T2=0Nm	$F_r Max$	N	5500
Maximum axial force based on gearbox axis and T2=0Nm	$F_a Max$	N	6400

$$(1) \text{ Max. motor weight* in kg} = \frac{0,2 \times M_b}{\text{motor length in m}}$$

* with symmetrically distributed motor weight
* with horizontal and stationary mounting

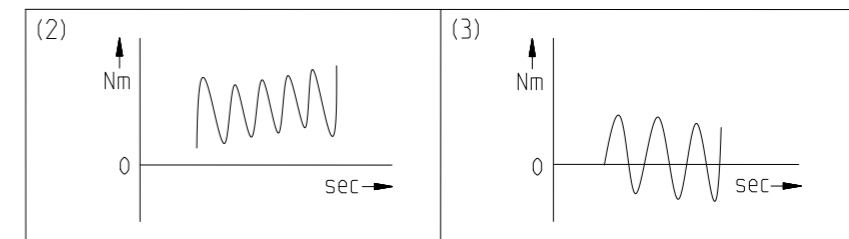

Ratio-dependent gearbox data	Character	Unit										
Ratio	bii	-	16	20	25	28	32	35	40	50	64	100
Nominal output torque No alternating torque (2)	T_{2N}	Nm	150	150	140	110	108	140	135	110	80	60
Nominal output torque Alternating torque permitted for 10.000.000 load changes (3)	$T_{2N 10Mio}$	Nm	76	76	76	76	76	76	76	76	76	60
Nominal output torque Alternating torque permitted for 100.000.000 load changes (3)	$T_{2N 100Mio}$	Nm	60	60	60	60	60	60	60	60	60	60
Max. output torque for 30.000 output shaft rotations (2)	T_{2max}	Nm	240	240	224	180	172	224	216	176	128	96
Emergency stop torque permitted 1000 times	T_{2Stop}	Nm	300	300	300	280	300	280	300	300	200	200
Average idle torque for $n_1=3.000$ rpm and 20 °C gearbox temperature	T_0	Nm	1.25	0.95	0.9	1.25	1.25	1.25	1.25	1.2	0.8	0.75
Average thermal input speed at 50% T_{2N} , S1, and T_{Amb} Operating temperature may not be exceeded!	$n_{1N 50\%}$	rpm	1800	2100	2250	2250	2300	2300	2300	2450	2950	3100
Average thermal input speed at 100% T_{2N} , S1, and T_{Amb} Operating temperature may not be exceeded!	$n_{1N 100\%}$	rpm	1400	1600	1850	1950	2000	2000	2000	2200	2750	3000
Max. mechanical input speed Operating temperature may not be exceeded!	$n_{1 Limit}$	rpm	16000	16000	16000	16000	16000	16000	16000	16000	16000	16000
Torsional backlash based on output shaft	j_t	arcmin	< 5	< 5	< 5	< 5	< 5	< 5	< 5	< 5	< 5	< 5
Torsional stiffness based on output shaft	c_g	Nm/arcmin	7.8	7.8	7.4	7.1	6.8	6.7	6.6	6.4	6.3	5.9
Efficiency at T_{2N} , gearbox temperature 70 °C and $n_1=1.000$ rpm	η	%	93	92	91	88	87	87	86	85	81	71
Running noise at $n_1=3.000$ rpm without load at a distance of 1m	Q_g	dB(A)	67	67	67	67	67	67	67	67	67	67
Gearbox weight	m_G	kg	6,3	6,3	6,3	6,3	6,3	6,3	6,3	6,3	6,4	6,4
Mass moment of inertia based on clamping system diameter input	J	kgcm ²	0.887	0.828	0.825	0.767	0.753	0.765	0.752	0.736	0.751	0.735

Subject to modifications.



WPLN090-bii-SSSA3AE-Z(D20)
/(L20)/(D21)/(D22)/B5/(G3)

Sheet 2/2

Revision status: P from: 08/2023