

Materials / Surfaces:

Input flange: Aluminum / untreated
 Angle housing: Aluminum / Anodized (black)
 Output flange: Steel / untreated

Hints:

Please pay attention to the operating and mounting instructions.
 Subject to modifications.

Variables on the drawing are dependent upon the motor.
 The given dimensions are exemplary.

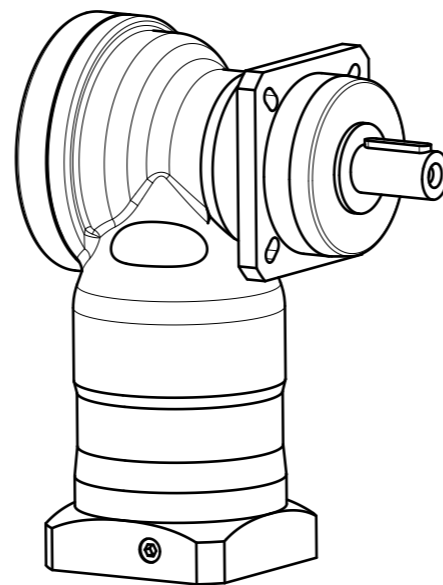

	Scale: 7:10	DIN A3	ISO
	Revision status: P from: 08/2023		
	Changed revision status: 0 from: 09/2022		
General tolerance DIN ISO 2768-cL	WPLN070-aii-SSSA3AD-Z(D20) /(L20)/(D21)/(D22)/B5/(G3)		
Neugart GmbH Keltenstr. 16 D-77971 Kippenheim			Sheet 1/2

General gearbox data	Character	Unit	
Bevel gearbox - gearing type	-	-	Hypoid teeth
Rotation direction	-	-	Input and output in opposite directions
Number of stages	p	-	1-stage
Output shaft bearing	-	-	Tapered roller bearing
Service life (L10h)	t_L	h	20.000
Max. operating temperature	T_{min} / T_{max}	°C	-25 / +90
Protection class	-	-	IP 65
Lubrication (lifetime lubrication)	-	-	Standard lubrication (Castrol Optigear Synthetic 800)
Installation position	-	-	Any
Max. bending moment based on the gearbox input flange (for motor weight) (1)	M_b	Nm	12
Motor shaft concentricity / Coaxiality and axial runout Motor flange	-	-	0,015 / 0,03 (Measuring methods according to DIN EN 50347)
Required motor shaft tolerance	-	-	j6; k6
Min. permissible motor shaft length	L_{20min}	mm	15
Reference operating mode	-	-	S1
Reference operating factor	K_A	-	1
Reference speed	n_2	rpm	100
Reference ambient temperature	T_{Amb}	°C	20
Radial force for output bearing based on shaft center after L10h=20.000h with Fa=0N	$F_r 20.000h$	N	3200
Axial force for output bearing based on gearbox axis after L10h=20.000h with Fr=0N	$F_a 20.000h$	N	4300
Radial force for output bearing based on shaft center after L10h=30.000h with Fa=0N	$F_r 30.000h$	N	3200
Axial force for output bearing based on gearbox axis after L10h=30.000h with Fr=0N	$F_a 30.000h$	N	3700
Maximum radial force based on shaft center and T2=0Nm	$F_r Max$	N	3200
Maximum axial force based on gearbox axis and T2=0Nm	$F_a Max$	N	4300

$$(1) \text{ Max. motor weight* in kg} = \frac{0,2 \times M_b}{\text{motor length in m}}$$

* with symmetrically distributed motor weight
* with horizontal and stationary mounting

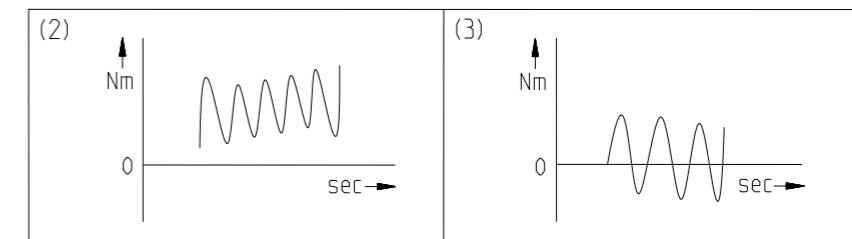

Ratio-dependent gearbox data	Character	Unit					
Ratio	aii	-	4	5	7	8	10
Nominal output torque No alternating torque (2)	T_{2N}	Nm	45	42	28	27	22
Nominal output torque Alternating torque permitted for 10.000.000 load changes (3)	$T_{2N 10Mio}$	Nm	37	37	28	27	22
Nominal output torque Alternating torque permitted for 100.000.000 load changes (3)	$T_{2N 100Mio}$	Nm	29	29	28	27	22
Max. output torque for 30.000 output shaft rotations (2)	T_{2max}	Nm	72	67	45	43	35
Emergency stop torque permitted 1000 times	T_{2stop}	Nm	100	100	75	75	75
Average idle torque for $n_1=3.000$ rpm and 20 °C gearbox temperature	T_0	Nm	1,5	1,35	1,3	1,25	1,2
Average thermal input speed at 50% T_{2N} , S1, and T_{Amb} Operating temperature may not be exceeded!	$n_{1N 50\%}$	rpm	1800	2000	2350	2350	2500
Average thermal input speed at 100% T_{2N} , S1, and T_{Amb} Operating temperature may not be exceeded!	$n_{1N 100\%}$	rpm	1450	1650	2100	2100	2300
Max. mechanical input speed Operating temperature may not be exceeded!	$n_{1 Limit}$	rpm	16000	16000	16000	16000	16000
Torsional backlash based on output shaft	j_f	arcmin	< 5	< 5	< 5	< 5	< 5
Torsional stiffness based on output shaft	c_g	Nm/arcmin	2,4	2,3	2,1	2	1,8
Efficiency at T_{2N} , gearbox temperature 70 °C and $n_1=1.000$ rpm	η	%	94	94	89	89	86
Running noise at $n_1=3.000$ rpm without load at a distance of 1m	Q_g	dB(A)	66	66	66	66	66
Gearbox weight	m_G	kg	3,4	3,4	3,4	3,4	3,4
Mass moment of inertia based on clamping system diameter input	J	kgcm ²	0,658	0,595	0,532	0,518	0,500

Subject to modifications.



WPLN070-aii-SSSA3AD-Z(D20)
/(L20)/(D21)/(D22)/B5/(G3)

Sheet 2/2

Revision status: P from: 08/2023