

Flange output shaft with dowel hole (ISO 9409-1)

Materials / Surfaces:

Input flange: Aluminum / untreated
 Angle housing: Aluminum / anodized (black)
 Intermediate flange: Aluminum / untreated
 Housing planetary stage: Steel / heat treated and post-oxidized (black)
 Output flange: Steel / untreated

Hints:

Please pay attention to the operating and mounting instructions.
 Subject to modifications.

Variables on the drawing are dependent upon the motor.
 The given dimensions are exemplary.

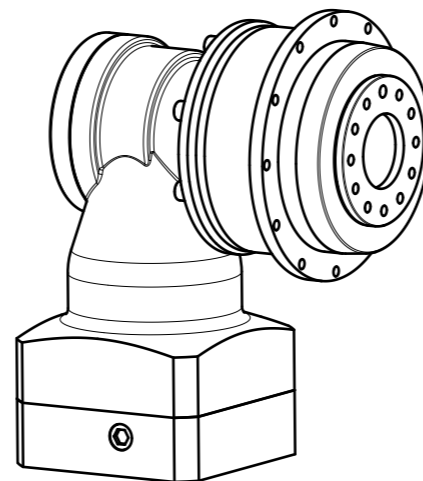

	Scale: 2:5	DIN A3	ISO
	Revision status: F from: 09/2022		
	Changed revision status: E from: 07/2021		
General tolerance DIN ISO 2768-cl	WPSFN140-bii-SSSE3AG-Y(D20) /(L20)/(D21)/(D22)/B5/(G3)		
Neugart GmbH Keltenstr. 16 D-77971 Kippenheim			Sheet 1/2

General gearbox data	Character	Unit	
Bevel gearbox - gearing type	-	-	Hypoid teeth
Planetary gearbox - gearing type	-	-	Helical teeth
Rotation direction	-	-	Input and output in opposite directions
Number of stages	p	-	2-stage
Output shaft bearing	-	-	Tapered roller bearing
Service life (L10h)	t_L	h	20.000
Max. operating temperature	T_{min} / T_{max}	°C	-25 / +90
Protection class	-	-	IP 65
Lubrication (Lifetime lubrication)	-	-	Standard lubrication (Castrol Optigear Synthetic 800)
Installation position	-	-	Any
Max. bending moment based on the gearbox input flange (for motor weight) (1)	M_b	Nm	53
Motor shaft concentricity / Coaxiality and axial runout Motor flange	-	-	0,015 / 0,03 (Measuring methods according to DIN EN 50347)
Required motor shaft tolerance	-	-	j6; k6
Min. permissible motor shaft length	L_{20min}	mm	37
Reference operating mode	-	-	S1
Reference operating factor	K_A	-	1
Reference speed	n_2	rpm	100
Reference ambient temperature	T_{Amb}	°C	20
Radial force for output bearing based on shaft end after L10h=20,000h with Fa=0N	$F_r 20.000h$	N	12000
Axial force for output bearing based on gearbox axis after L10h=20,000h with Fr=0N	$F_a 20.000h$	N	8500
Radial force for output bearing based on shaft end after L10h=30,000h with Fa=0N	$F_r 30.000h$	N	11000
Axial force for output bearing based on gearbox axis after L10h=30,000h with Fr=0N	$F_a 30.000h$	N	7500
Maximum radial force based on shaft end and T2=0Nm	$F_r Max$	N	12000
Maximum axial force based on gearbox axis and T2=0Nm	$F_a Max$	N	8500

$$(1) \text{ Max. motor weight* in kg} = \frac{0,2 \times M_b}{\text{motor length in m}}$$

- * with symmetrically distributed motor weight
- * with horizontal and stationary mounting

Ratio-dependent gearbox data	Character	Unit										
Ratio	bii	-	16	20	25	28	32	35	40	50	70	100
Nominal output torque	T_{2N}	Nm	625	560	540	364	360	455	450	375	355	305
Max. output torque for 30,000 output shaft rotations	T_{2max}	Nm	1003	896	864	580	576	725	720	600	568	488
Emergency stop torque permitted 1000 times	T_{2stop}	Nm	1600	1600	1650	1200	1200	1500	1500	1500	1300	600
Average idle torque for $n_1=3,000$ rpm and 20 °C gearbox temperature	T_0	Nm	8.3	7.5	7.3	6.8	6.6	6.6	6.5	6.3	5.1	4
Average thermal input speed at 50% T2N, S1, and T_Amb Operating temperature may not be exceeded!	$n_{1N 50\%}$	rpm	1400	1350	1450	1650	1650	1650	1650	1750	1950	2150
Average thermal input speed at 100% T2N, S1, and T_Amb Operating temperature may not be exceeded!	$n_{1N 100\%}$	rpm	1200	1150	1250	1500	1500	1550	1500	1650	1850	2100
Max. mechanical input speed Operating temperature may not be exceeded!	$n_{1 Limit}$	rpm	9500	9500	9500	9500	9500	9500	9500	9500	9500	9500
Torsional backlash based on output shaft	j_f	arcmin	< 5	< 5	< 5	< 5	< 5	< 5	< 5	< 5	< 5	< 5
Torsional stiffness based on output shaft	c_g	Nm/arcmin	111	111	106	102	98	96	94	93	90	85
Efficiency at T2N, gearbox temperature 70 °C and $n_1=1,000$ rpm	η	%	93	92	90	87	85	87	85	80	75	67
Running noise at $n_1=3,000$ rpm without load at a distance of 1m	Q_g	dB(A)	70	70	70	70	70	70	70	70	70	70
Gearbox weight	m_G	kg	21.7	21.8	21.7	21.6	21.7	21.6	21.7	21.7	22.1	22.1
Mass moment of inertia based on clamping system diameter input	J	kgcm ²	8.152	7.964	7.317	6.808	6.701	6.78	6.679	6.532	6.52	6.514

Subject to modifications.



WPSFN140-bii-SSSE3AG-Y(D20)
/(L20)/(D21)/(D22)/B5/(G3)

Sheet 2/2

Revision status: F from: 09/2022