

Flange output shaft with dowel hole (ISO 9409-1)

**Materials / Surfaces:**

Input flange: Aluminum / untreated  
 Angle housing: Aluminum / anodized (black)  
 Intermediate flange: Aluminum / untreated  
 Housing planetary stage: Steel / heat treated and post-oxidized (black)  
 Output flange: Steel / untreated

**Hints:**

Please pay attention to the operating and mounting instructions.  
 Subject to modifications.

Variables on the drawing are dependent upon the motor.  
 The given dimensions are exemplary.

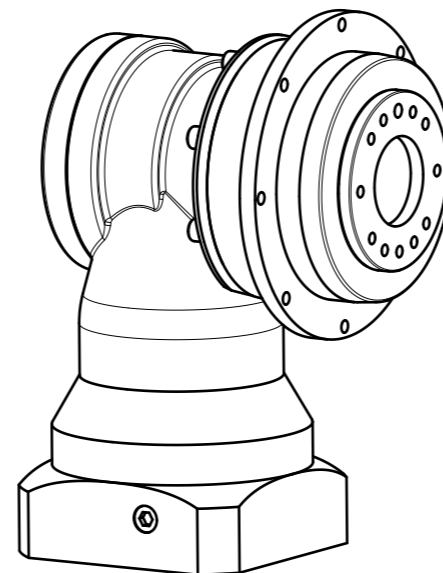

	Scale: 1:2	DIN A3	ISO
	Revision status: F from: 09/2022		
Changed revision status: E from: 07/2021			
General tolerance DIN ISO 2768-cl	WPSFN110-bii-SSSE3AF-Z(D20) /(L20)/(D21)/(D22)/B5/(G3)		
Neugart GmbH Keltenstr. 16 D-77971 Kippenheim			Sheet 1/2

General gearbox data	Character	Unit	
Bevel gearbox - gearing type	-	-	Hypoid teeth
Planetary gearbox - gearing type	-	-	Helical teeth
Rotation direction	-	-	Input and output in opposite directions
Number of stages	p	-	2-stage
Output shaft bearing	-	-	Inclined roller bearings
Service life (L10h)	$t_L$	h	20.000
Max. operating temperature	$T_{min} / T_{max}$	°C	-25 / +90
Protection class	-	-	IP 65
Lubrication (Lifetime lubrication)	-	-	Standard lubrication (Castrol Optigear Synthetic 800)
Installation position	-	-	Any
Max. bending moment based on the gearbox input flange (for motor weight) (1)	$M_b$	Nm	25,5
Motor shaft concentricity / Coaxiality and axial runout Motor flange	-	-	0,015 / 0,03 (Measuring methods according to DIN EN 50347)
Required motor shaft tolerance	-	-	j6; k6
Min. permissible motor shaft length	$L_{20min}$	mm	28
Reference operating mode	-	-	S1
Reference operating factor	$K_A$	-	1
Reference speed	$n_2$	rpm	100
Reference ambient temperature	$T_{Amb}$	°C	20
Radial force for output bearing based on shaft end after L10h=20,000h with Fa=0N	$F_r 20.000h$	N	4900
Axial force for output bearing based on gearbox axis after L10h=20,000h with Fr=0N	$F_a 20.000h$	N	9500
Radial force for output bearing based on shaft end after L10h=30,000h with Fa=0N	$F_r 30.000h$	N	4350
Axial force for output bearing based on gearbox axis after L10h=30,000h with Fr=0N	$F_a 30.000h$	N	8400
Maximum radial force based on shaft end and T2=0Nm	$F_r Max$	N	4900
Maximum axial force based on gearbox axis and T2=0Nm	$F_a Max$	N	9500

$$(1) \text{ Max. motor weight* in kg} = \frac{0,2 \times M_b}{\text{motor length in m}}$$

- \* with symmetrically distributed motor weight
- \* with horizontal and stationary mounting

Ratio-dependent gearbox data	Character	Unit										
Ratio	bii	-	16	20	25	28	32	35	40	50	70	100
Nominal output torque	$T_{2N}$	Nm	310	300	255	204	200	255	250	200	175	140
Max. output torque for 30,000 output shaft rotations	$T_{2max}$	Nm	502	480	408	328	320	410	400	320	280	224
Emergency stop torque permitted 1000 times	$T_{2stop}$	Nm	650	650	650	600	600	650	650	650	340	480
Average idle torque for $n_1=3,000$ rpm and 20 °C gearbox temperature	$T_0$	Nm	2,9	2,5	2	2,1	2,1	2,1	2	1,9	1,55	1,2
Average thermal input speed at 50% T2N, S1, and T_Amb Operating temperature may not be exceeded!	$n_{1N 50\%}$	rpm	1750	2000	2300	2400	2450	2450	2500	2650	3000	3300
Average thermal input speed at 100% T2N, S1, and T_Amb Operating temperature may not be exceeded!	$n_{1N 100\%}$	rpm	1400	1600	2000	2150	2200	2200	2200	2450	2850	3200
Max. mechanical input speed Operating temperature may not be exceeded!	$n_{1 Limit}$	rpm	14000	14000	14000	14000	14000	14000	14000	14000	14000	14000
Torsional backlash based on output shaft	$j_f$	arcmin	< 5	< 5	< 5	< 5	< 5	< 5	< 5	< 5	< 5	< 5
Torsional stiffness based on output shaft	$c_g$	Nm/arcmin	44	44	41,5	40	38,5	37,5	37,5	36,5	35,5	33,5
Efficiency at T2N, gearbox temperature 70 °C and $n_1=1,000$ rpm	$\eta$	%	93	92	91	89	88	89	88	84	79	70
Running noise at $n_1=3,000$ rpm without load at a distance of 1m	$Q_g$	dB(A)	68	68	68	68	68	68	68	68	68	68
Gearbox weight	$m_G$	kg	9,9	10	10	10,1	10	10,1	10	10	10,1	9,8
Mass moment of inertia based on clamping system diameter input	J	kgcm <sup>2</sup>	2,73	2,54	2,524	2,386	2,346	2,378	2,34	2,298	2,294	2,293

Subject to modifications.



WPSFN110-bii-SSSE3AF-Z(D20)  
/(L20)/(D21)/(D22)/B5/(G3)

Sheet 2/2

Revision status: F from: 09/2022