

Flange output hollow shaft with dowel hole (ISO 9409-1)

Materials / Surfaces:

Input flange: Aluminum / untreated
 Angle housing: Aluminum / anodized (black)
 Output flange: Steel / untreated

Hints:

Please pay attention to the operating and mounting instructions.
 Subject to modifications.

Variables on the drawing are dependent upon the motor.
 The given dimensions are exemplary.

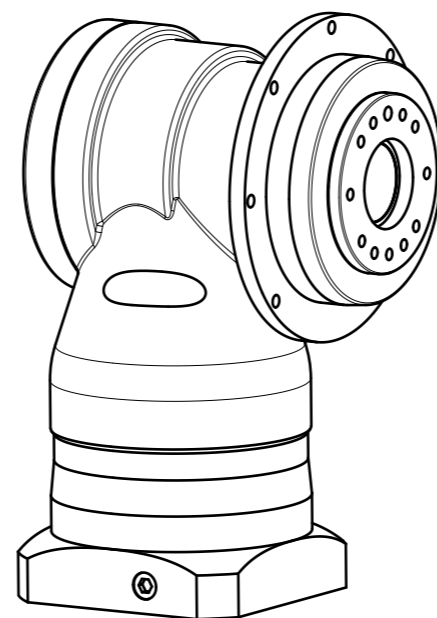
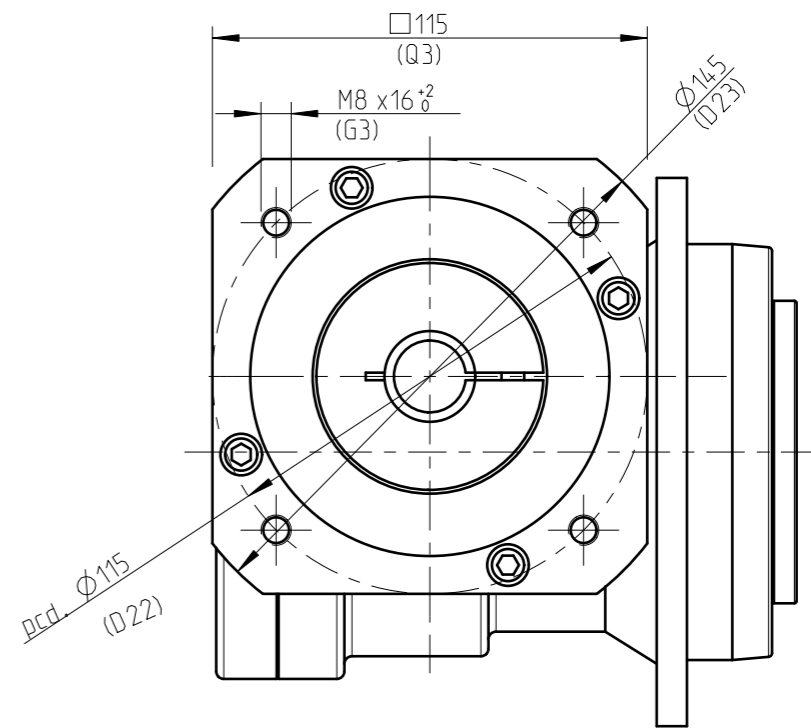
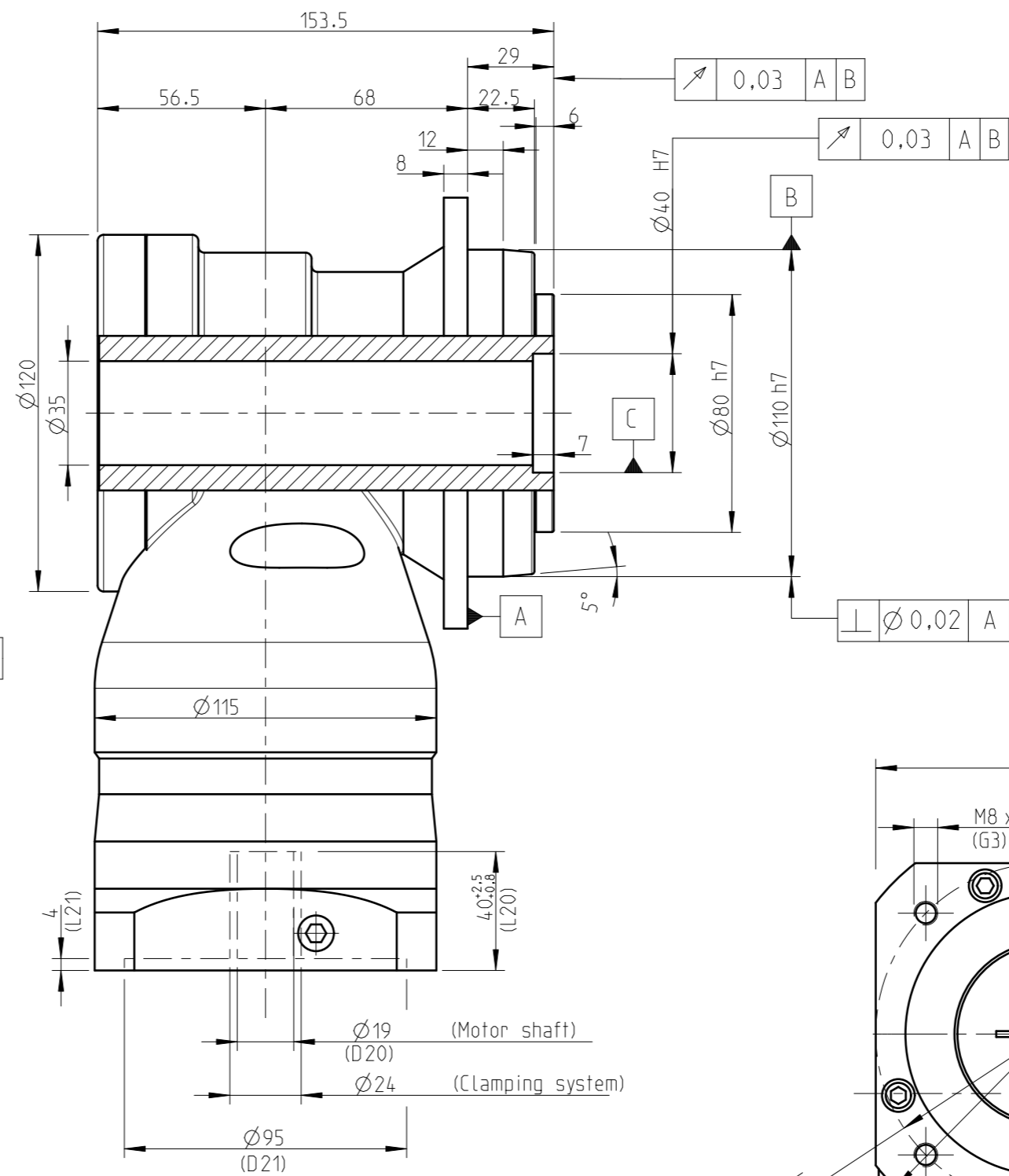

	Scale: 1:2	DIN A3	ISO
	Revision status: F from: 09/2022		
	Changed revision status: E from: 07/2021		
General tolerance DIN ISO 2768-cl	WPSFN110-aii-SSSH3AF-Z(D20) /(L20)/(D21)/(D22)/B5/(G3)		
Neugart GmbH Keltenstr. 16 D-77971 Kippenheim			Sheet 1/2

General gearbox data	Character	Unit	
Bevel gearbox - gearing type	-	-	Hypoid teeth
Rotation direction	-	-	Input and output in opposite directions
Number of stages	p	-	1-stage
Output shaft bearing	-	-	Inclined roller bearings
Service life (L10h)	t_L	h	20.000
Max. operating temperature	T_{min} / T_{max}	°C	-25 / +90
Protection class	-	-	IP 65
Lubrication (Lifetime lubrication)	-	-	Standard lubrication (Castrol Optigear Synthetic 800)
Installation position	-	-	Any
Max. bending moment based on the gearbox input flange (for motor weight) (1)	M_b	Nm	53
Motor shaft concentricity / Coaxiality and axial runout Motor flange	-	-	0,015 / 0,03 (Measuring methods according to DIN EN 50347)
Required motor shaft tolerance	-	-	j6; k6
Min. permissible motor shaft length	L_{20min}	mm	18
Reference operating mode	-	-	S1
Reference operating factor	K_A	-	1
Reference speed	n_2	rpm	100
Reference ambient temperature	T_{Amb}	°C	20
Radial force for output bearing based on shaft end after L10h=20,000h with Fa=0N	$F_r 20.000h$	N	5500
Axial force for output bearing based on gearbox axis after L10h=20,000h with Fr=0N	$F_a 20.000h$	N	9500
Radial force for output bearing based on shaft end after L10h=30,000h with Fa=0N	$F_r 30.000h$	N	4800
Axial force for output bearing based on gearbox axis after L10h=30,000h with Fr=0N	$F_a 30.000h$	N	8400
Maximum radial force based on shaft end and T2=0Nm	$F_r Max$	N	5500
Maximum axial force based on gearbox axis and T2=0Nm	$F_a Max$	N	9500

$$(1) \text{ Max. motor weight* in kg} = \frac{0,2 \times M_b}{\text{motor length in m}}$$

- * with symmetrically distributed motor weight
- * with horizontal and stationary mounting

Ratio-dependent gearbox data	Character	Unit					
Ratio	aii	-	4	5	7	8	10
Nominal output torque	T_{2N}	Nm	160	140	91	90	75
Max. output torque for 30,000 output shaft rotations	T_{2max}	Nm	256	224	145	144	120
Emergency stop torque permitted 1000 times	T_{2stop}	Nm	400	400	300	300	300
Average idle torque for $n_1=3,000$ rpm and 20 °C gearbox temperature	T_0	Nm	7,4	6,9	6,5	6,3	6,2
Average thermal input speed at 50% T2N, S1, and T_Amb Operating temperature may not be exceeded!	$n_{1N 50\%}$	rpm	1100	1200	1450	1450	1500
Average thermal input speed at 100% T2N, S1, and T_Amb Operating temperature may not be exceeded!	$n_{1N 100\%}$	rpm	850	1000	1300	1300	1400
Max. mechanical input speed Operating temperature may not be exceeded!	$n_{1 Limit}$	rpm	9500	9500	9500	9500	9500
Torsional backlash based on output shaft	j_f	arcmin	< 5	< 5	< 5	< 5	< 5
Torsional stiffness based on output shaft	c_g	Nm/arcmin	13,5	12,8	12	11,1	10,1
Efficiency at T2N, gearbox temperature 70 °C and $n_1=1,000$ rpm	η	%	94	93	88	87	83
Running noise at $n_1=3,000$ rpm without load at a distance of 1m	Q_g	dB(A)	68	68	68	68	68
Gearbox weight	m_G	kg	11,7	11,7	11,6	11,7	11,7
Mass moment of inertia based on clamping system diameter input	J	kgcm ²	6,435	5,725	5,134	5,019	4,857

Subject to modifications.



WPSFN110-aii-SSSH3AF-Z(D20)
/(L20)/(D21)/(D22)/B5/(G3)

Sheet 2/2

Revision status: F from: 09/2022