

Flange output shaft with dowel hole (ISO 9409-1)

**Materials / Surfaces:**

Input flange: Aluminum / untreated  
 Angle housing: Aluminum / anodized (black)  
 Intermediate flange: Aluminum / untreated  
 Housing planetary stage: Steel / heat treated and post-oxidized (black)  
 Output flange: Steel / untreated

**Hints:**

Please pay attention to the operating and mounting instructions.  
 Subject to modifications.

Variables on the drawing are dependent upon the motor.  
 The given dimensions are exemplary.

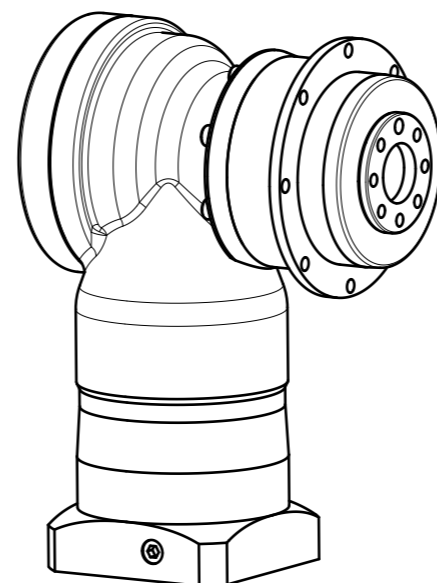

	Scale: 7:10	DIN A3	ISO
	Revision status: F from: 09/2022		
Changed revision status: E from: 07/2021			
General tolerance DIN ISO 2768-cl	W PSFN064-bii-SSSE3AD-Z(D20) /(L20)/(D21)/(D22)/B5/(G3)		
Neugart GmbH Keltenstr. 16 D-77971 Kippenheim	Sheet 1/2		

General gearbox data	Character	Unit	
Bevel gearbox - gearing type	-	-	Hypoid teeth
Planetary gearbox - gearing type	-	-	Helical teeth
Rotation direction	-	-	Input and output in opposite directions
Number of stages	p	-	2-stage
Output shaft bearing	-	-	Inclined roller bearings
Service life (L10h)	$t_L$	h	20.000
Max. operating temperature	$T_{min} / T_{max}$	°C	-25 / +90
Protection class	-	-	IP 65
Lubrication (Lifetime lubrication)	-	-	Standard lubrication (Castrol Optigear Synthetic 800)
Installation position	-	-	Any
Max. bending moment based on the gearbox input flange (for motor weight) (1)	$M_b$	Nm	12
Motor shaft concentricity / Coaxiality and axial runout Motor flange	-	-	0,015 / 0,03 (Measuring methods according to DIN EN 50347)
Required motor shaft tolerance	-	-	j6; k6
Min. permissible motor shaft length	$L_{20min}$	mm	15
Reference operating mode	-	-	S1
Reference operating factor	$K_A$	-	1
Reference speed	$n_2$	rpm	100
Reference ambient temperature	$T_{Amb}$	°C	20
Radial force for output bearing based on shaft end after L10h=20,000h with Fa=0N	$F_r 20.000h$	N	2150
Axial force for output bearing based on gearbox axis after L10h=20,000h with Fr=0N	$F_a 20.000h$	N	4300
Radial force for output bearing based on shaft end after L10h=30,000h with Fa=0N	$F_r 30.000h$	N	1900
Axial force for output bearing based on gearbox axis after L10h=30,000h with Fr=0N	$F_a 30.000h$	N	3800
Maximum radial force based on shaft end and T2=0Nm	$F_r Max$	N	2150
Maximum axial force based on gearbox axis and T2=0Nm	$F_a Max$	N	4300

$$(1) \text{ Max. motor weight* in kg} = \frac{0,2 \times M_b}{\text{motor length in m}}$$

- \* with symmetrically distributed motor weight
- \* with horizontal and stationary mounting

Ratio-dependent gearbox data	Character	Unit										
Ratio	bii	-	16	20	25	28	32	35	40	50	70	100
Nominal output torque	$T_{2N}$	Nm	62	62	60	62	62	60	60	60	37	28
Max. output torque for 30,000 output shaft rotations	$T_{2max}$	Nm	99	99	96	99	99	96	96	96	59	45
Emergency stop torque permitted 1000 times	$T_{2stop}$	Nm	150	150	150	150	150	150	150	150	80	90
Average idle torque for $n_1=3,000$ rpm and 20 °C gearbox temperature	$T_0$	Nm	1,1	0,95	0,95	1	1	0,85	0,8	1	0,8	0,8
Average thermal input speed at 50% T2N, S1, and T_Amb Operating temperature may not be exceeded!	$n_{1N 50\%}$	rpm	2250	2400	2500	2550	2550	2750	2800	2750	3000	3050
Average thermal input speed at 100% T2N, S1, and T_Amb Operating temperature may not be exceeded!	$n_{1N 100\%}$	rpm	2000	2200	2300	2350	2400	2550	2600	2600	2900	3000
Max. mechanical input speed Operating temperature may not be exceeded!	$n_{1 Limit}$	rpm	16000	16000	16000	16000	16000	16000	16000	16000	16000	16000
Torsional backlash based on output shaft	$j_f$	arcmin	< 5	< 5	< 5	< 5	< 5	< 5	< 5	< 5	< 5	< 5
Torsional stiffness based on output shaft	$c_g$	Nm/arcmin	6,9	6,9	6,7	6,3	6	6	6	5,8	5,5	5,3
Efficiency at T2N, gearbox temperature 70 °C and $n_1=1,000$ rpm	$\eta$	%	88	87	84	83	81	82	79	75	61	59
Running noise at $n_1=3,000$ rpm without load at a distance of 1m	$Q_g$	dB(A)	66	66	66	66	66	66	66	66	66	66
Gearbox weight	$m_G$	kg	4	4	4	3,9	4	3,9	4	4	4	4
Mass moment of inertia based on clamping system diameter input	J	kgcm <sup>2</sup>	0,642	0,585	0,584	0,527	0,514	0,526	0,513	0,497	0,497	0,497

Subject to modifications.



WPSFN064-bii-SSSE3AD-Z(D20)  
/(L20)/(D21)/(D22)/B5/(G3)

Sheet 2/2

Revision status: F from: 09/2022