

Materials / Surfaces:

Input flange: Aluminum / untreated
 Angle housing: Aluminum / Anodized (black)
 Output flange: Steel / untreated

Hints:

Please pay attention to the operating and mounting instructions.
 Subject to modifications.

Variables on the drawing are dependent upon the motor.
 The given dimensions are exemplary

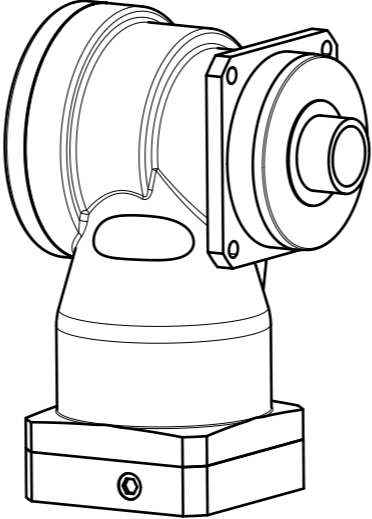

	Scale: 2:5	DIN A3	ISO
	Revision status: F from: 12/2022	Changed revision status: E from: 09/2018	
General tolerance DIN ISO 2768-cl	W GN142-aii-SSSG3AG-Y(D20) / (L20)/(D21)/(D22)/B5/(G3)		
Neugart GmbH Keltenstr. 16 D-77971 Kippenheim			Sheet 1/2

General gearbox data	Character	Unit	
Bevel gearbox - gearing type	-	-	Hypoid teeth
Rotation direction	-	-	Input and output in opposite directions
Number of stages	p	-	1-stage
Output shaft bearing	-	-	Tapered roller bearing
Service life (L10h)	t_L	h	20.000
Max. operating temperature	T_{min} / T_{max}	°C	-25 / +90
Protection class	-	-	IP 65
Lubrication (Lifetime lubrication)	-	-	Standard Lubrication (Castrol Optigear Synthetic 800)
Installation position	-	-	Any
Max. bending moment based on the gearbox input flange (for motor weight) (1)	M_b	Nm	120
Motor shaft concentricity / Coaxiality and axial runout Motor flange	-	-	0,02 / 0,05 (Measuring methods according to DIN EN 50347)
Required motor shaft tolerance	-	-	j6; k6
Min. permissible motor shaft length	L_{20min}	mm	27
Reference operating mode	-	-	S1
Reference operating factor	K_A	-	1
Reference speed	n_2	rpm	100
Reference ambient temperature	T_{Amb}	°C	20
Radial force for output bearing based on shaft center after L10h=20.000h with Fa=0N	$F_r 20.000h$	N	10000
Axial force for output bearing based on gearbox axis after L10h=20.000h with Fr=0N	$F_a 20.000h$	N	14500
Radial force for output bearing based on shaft center after L10h=30.000h with Fa=0N	$F_r 30.000h$	N	10000
Axial force for output bearing based on gearbox axis after L10h=30.000h with Fr=0N	$F_a 30.000h$	N	12000
Maximum radial force based on shaft center and T2=0Nm	$F_r Max$	N	10000
Maximum axial force based on gearbox axis and T2=0Nm	$F_a Max$	N	14500

$$(1) \text{ Max. motor weight* in kg} = \frac{0,2 \times M_b}{\text{motor length in m}}$$

- * with symmetrically distributed motor weight
- * with horizontal and stationary mounting

Ratio-dependent gearbox data	Character	Unit					
Ratio	aii	-	4	5	7	8	10
Nominal output torque	T_{2N}	Nm	320	280	189	180	160
Max. output torque for 30,000 output shaft rotations (2)	T_{2max}	Nm	512	448	302	288	256
Emergency stop torque permitted 1000 times	T_{2stop}	Nm	800	800	700	700	700
Average idle torque for $n_1=3,000$ rpm and 20 °C gearbox temperature	T_0	Nm	16,1	16,1	16	16,1	16,1
Average thermal input speed at 50% T_{2N} , S1, and T_{Amb} Operating temperature may not be exceeded!	$n_{1N 50\%}$	rpm	950	950	1200	1050	1050
Average thermal input speed at 100% T_{2N} , S1, and T_{Amb} Operating temperature may not be exceeded!	$n_{1N 100\%}$	rpm	750	800	1100	900	950
Max. mechanical input speed Operating temperature may not be exceeded!	$n_{1 Limit}$	rpm	8000	8000	8000	8000	8000
Torsional backlash based on output shaft	j_f	arcmin	< 5	< 5	< 5	< 5	< 5
Torsional stiffness based on output shaft	c_g	Nm/arcmin	31,5	29,5	27,5	25,5	23,5
Efficiency at T_{2N} , gearbox temperature 70 °C and $n_1=1,000$ rpm	η	%	95	94	90	92	92
Running noise at $n_1=3,000$ rpm without load at a distance of 1m	Q_g	dB(A)	70	70	70	70	70
Gearbox weight	m_G	kg	23,3	23,7	23,6	23,8	23,7
Mass moment of inertia based on clamping system diameter input	J	kgcm ²	18,905	16,252	14,025	13,568	12,934

Subject to modifications.



W GN142-aii-SSSG3AG-Y(D20)
/(L20)/(D21)/(D22)/B5/(G3)

Sheet 2/2

Revision status: F from: 12/2022