

Flange output shaft (similar ISO 9409-1)

Materials / Surfaces:

Input flange: Aluminum / untreated
Housing: Steel / heat-treated and post-oxidized (black)
Output flange: Steel / untreated

Hints:

Please pay attention to the operating and mounting instructions.
Subject to modifications.

Variables on the drawing are dependent upon the motor.
The given dimensions are exemplary

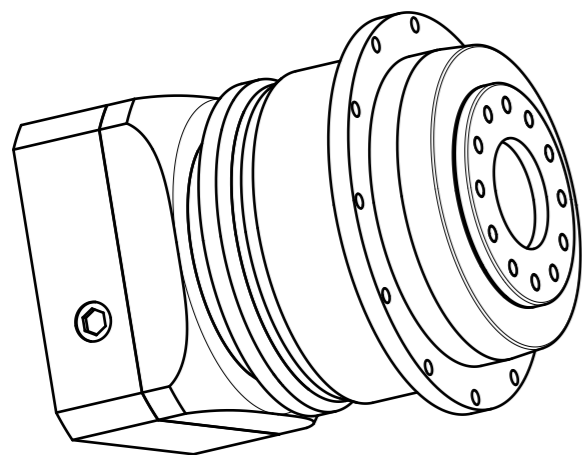

	Scale: 2:5	DIN A3	ISO
	Revision status: Q from: 05/2022		
Changed revision status: P from: 01/2021			
General tolerance DIN ISO 2768-cL	PLFN140-bii-SSSD3AG-Y(D20) /(L20)/(D21)/(D22)/B5/(G3)		
Neugart GmbH Keltenstr. 16 D-77971 Kippenheim			Sheet 1/2

General gearbox data	Character	Unit	
Planetary gearbox - gearing type	-	-	Straight teeth
Rotation direction	-	-	Input and output in the same direction
Number of stages	p	-	2-stage
Output shaft bearing	-	-	Tapered roller bearing
Service life (L10h)	t_L	h	20.000
Max. operating temperature	T_{min} / T_{max}	°C	-25 / +90
Protection class	-	-	IP 65
Lubrication (Lifetime lubrication)	-	-	Standard lubrication (Castrol Optigear Synthetic 800/150)
Installation position	-	-	Any
Max. bending moment based on the gearbox input flange (for motor weight) (1)	M_b	Nm	80
Motor shaft concentricity / Coaxiality and axial runout Motor flange	-	mm	0,015 / 0,03 (Measuring methods according to DIN EN 50347)
Required motor shaft tolerance	-	-	j6; k6
Min. permissible motor shaft length	$L_{20 min}$	mm	37
Reference operating mode	-	-	S1
Reference operating factor	K_A	-	1
Reference speed	n_2	rpm	100
Reference ambient temperature	T_{Amb}	°C	20
Radial force for output bearing based on shaft end after L10h=20,000h with $F_a=0N$	$F_r 20.000h$	N	12000
Axial force for output bearing based on gearbox axis after L10h=20,000h with $F_r=0N$	$F_a 20.000h$	N	8500
Radial force for output bearing based on shaft end after L10h=30,000h with $F_a=0N$	$F_r 30.000h$	N	11000
Axial force for output bearing based on gearbox axis after L10h=30,000h with $F_r=0N$	$F_a 30.000h$	N	7500
Maximum radial force based on shaft end and $T_2=0Nm$	$F_r Max$	N	12000
Maximum axial force based on gearbox axis and $T_2=0Nm$	$F_a Max$	N	8500

$$(1) \text{ Max. motor weight* in kg} = \frac{0,2 \times M_b}{\text{motor length in m}}$$

- * with symmetrically distributed motor weight
- * with horizontal and stationary mounting

Ratio-dependent gearbox data	Character	Unit								
Ratio	bii	-	16	20	25	32	40	50	64	100
Nominal output torque	T_{2N}	Nm	1000	1000	900	600	750	620	450	305
Max. output torque for 30.000 output shaft rotations	T_{2max}	Nm	1600	1600	1440	960	1200	992	720	488
Emergency stop torque permitted 1000 times	T_{2stop}	Nm	2000	2000	1800	1500	1500	1500	1000	750
Average idle torque for $n_1=3.000$ rpm and 20 °C gearbox temperature	T_0	Nm	3	2,05	1,85	1,1	1	0,85	0,85	0,75
Average thermal input speed at 50% T_{2N} , S1, and T_{Amb} Operating temperature may not be exceeded!	$n_{1N 50\%}$	rpm	1700	2100	2500	3500	3500	3500	3500	3500
Average thermal input speed at 100% T_{2N} , S1, and T_{Amb} Operating temperature may not be exceeded!	$n_{1N 100\%}$	rpm	1200	1450	1800	2850	2950	3500	3500	3500
Max. mechanical input speed Operating temperature may not be exceeded!	$n_{1 Limit}$	rpm	8500	8500	8500	8500	8500	8500	8500	8500
Torsional backlash based on output shaft	j_t	arcmin	< 5	< 5	< 5	< 5	< 5	< 5	< 5	< 5
Torsional stiffness based on output shaft	c_g	Nm/arcmin	225	232	265	212	252	241	182	177
Efficiency at T_{2N} , gearbox temperature 70 °C and $n_1=1.000$ rpm	η	%	96	96	96	95	95	94	93	89
Running noise at $n_1=3.000$ rpm without load at a distance of 1m	Q_g	dB(A)	70	70	70	70	70	70	70	70
Gearbox weight	m_G	kg	16,8	16,8	16,9	16,8	16,9	16,3	16,9	17
Mass moment of inertia based on clamping system diameter input	J	kgcm ²	8,253	7,046	6,878	6,715	6,607	6,596	6,644	6,57



PLFN140-bii-SSSD3AG-Y(D20)
/(L20)/(D21)/(D22)/B5/(G3)

Sheet 2/2

Subject to modifications.

Revision status: Q from: 05/2022