

Materials / Surfaces:

Input flange: Aluminum / untreated
Housing: Steel / heat-treated and post-oxidized (black)
Output flange: Steel / untreated

Hints:

Please pay attention to the operating and mounting instructions.
Subject to modifications.

Variables on the drawing are dependent upon the motor.
The given dimensions are exemplary.

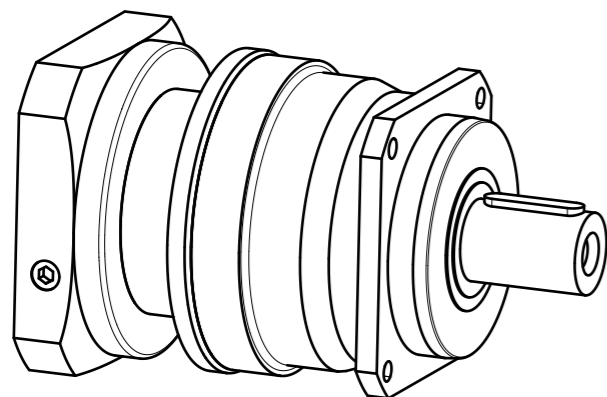

	Scale: 3:10	DIN A3	ISO
	Revision status: E from: 04/2022		
	Changed revision status: D from: 03/2020		
General tolerance DIN ISO 2768-cl	PSN190-bii-SSSA3AH-Z(D20) /(L20)/(D21)/(D22)/B5/(G3)		
Neugart GmbH Keltenstr. 16 D-77971 Kippenheim			Sheet 1/2

General gearbox data	Character	Unit	
Planetary gearbox - gearing type	-	-	Helical teeth
Rotation direction	-	-	Input and output in the same direction
Number of stages	p	-	2-stage
Output shaft bearing	-	-	Tapered roller bearing
Service life (L10h)	t_L	h	20.000
Max. operating temperature	T_{min} / T_{max}	°C	-25 / +90
Protection class	-	-	IP 65
Lubrication (Lifetime lubrication)	-	-	Standard lubrication (Castrol Optigear Synthetic 800/220)
Installation position	-	-	Any
Max. bending moment based on the gearbox input flange (for motor weight) (1)	M_b	Nm	180
Motor shaft concentricity / Coaxiality and axial runout Motor flange	-	-	0,025 / 0,05 (Measuring methods according to DIN EN 50347)
Required motor shaft tolerance	-	-	j6; k6
Min. permissible motor shaft length	$L_{20 \text{ min}}$	mm	36
Reference operating mode	-	-	S1
Reference operating factor	K_A	-	1
Reference speed	n_2	rpm	100
Reference ambient temperature	T_{Amb}	°C	20
Radial force for output bearing based on shaft center after L10h=20,000h with Fa=0N	$F_r 20.000h$	N	20000
Axial force for output bearing based on gearbox axis after L10h=20,000h with Fr=0N	$F_a 20.000h$	N	19000
Radial force for output bearing based on shaft center after L10h=30,000h with Fa=0N	$F_r 30.000h$	N	17500
Axial force for output bearing based on gearbox axis after L10h=30,000h with Fr=0N	$F_a 30.000h$	N	18500
Maximum radial force based on shaft center and T2=0Nm	$F_r \text{ Max}$	N	20000
Maximum axial force based on gearbox axis and T2=0Nm	$F_a \text{ Max}$	N	19000

$$(1) \text{ Max. motor weight* in kg} = \frac{0.2 \times M_b}{\text{motor length in m}}$$

* with symmetrically distributed motor weight
* with horizontal and stationary mounting

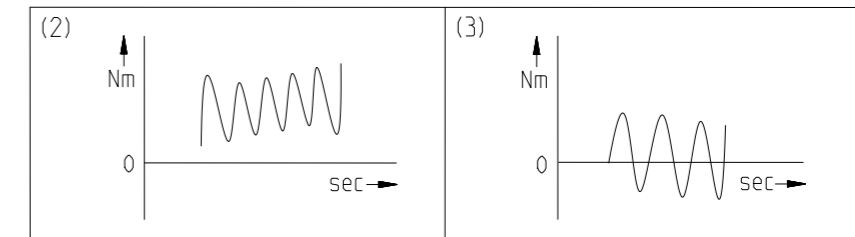

Ratio-dependent gearbox data	Character	Unit										
Ratio	bii	-	12	15	16	20	25	35	40	50	70	100
Nominal output torque No alternating torque (2)	T_{2N}	Nm	845	845	950	950	950	950	950	950	900	750
Nominal output torque Alternating torque permitted for 10,000,000 load changes (3)	$T_{2N 10Mio}$	Nm	693	693	693	693	693	693	693	693	693	693
Nominal output torque Alternating torque permitted for 100,000,000 load changes (3)	$T_{2N 100Mio}$	Nm	550	550	550	550	550	550	550	550	550	550
Max. output torque for 30,000 output shaft rotations (2)	T_{2max}	Nm	1352	1352	1520	1520	1520	1520	1520	1520	1440	1200
Emergency stop torque permitted 1000 times	T_{2Stop}	Nm	2400	2400	3200	3200	3200	3200	3200	3200	3200	1700
Average idle torque for $n_1=3,000$ rpm and 20 °C gearbox temperature	T_0	Nm	7,3	5,1	6,9	4,7	4,3	2,8	2,05	1,9	1,8	1,75
Average thermal input speed at 50% T_{2N} , S1, and T_{Amb} Operating temperature may not be exceeded!	$n_{1N 50\%}$	rpm	1550	1900	1650	2050	2200	2800	3000	3000	3000	3000
Average thermal input speed at 100% T_{2N} , S1, and T_{Amb} Operating temperature may not be exceeded!	$n_{1N 100\%}$	rpm	1350	1650	1500	1800	2000	2550	2950	3000	3000	3000
Max. mechanical input speed Operating temperature may not be exceeded!	$n_1 \text{ Limit}$	rpm	6500	6500	6500	6500	6500	6500	6500	6500	6500	6500
Torsional backlash based on output shaft	j_t	arcmin	< 5	< 5	< 5	< 5	< 5	< 5	< 5	< 5	< 5	< 5
Torsional stiffness based on output shaft	c_g	Nm/arcmin	197	198	227	228	217	215	219	212	199	179
Efficiency at T_{2N} , gearbox temperature 70 °C and $n_1=1,000$ rpm	η	%	97	97	96	96	96	96	96	95	94	91
Running noise at $n_1=3,000$ rpm without load at a distance of 1m	Q_g	dB(A)	68	68	68	68	68	68	68	68	68	68
Gearbox weight	m_G	kg	43,9	43,2	43,9	43,9	44,4	44,5	43,8	44,2	44,5	44,7
Mass moment of inertia based on clamping system diameter input	J	kgcm ²	14,22	12,453	13,126	11,753	11,497	10,507	10,068	10,004	9,951	9,927

Subject to modifications.



PSN190-bii-SSSA3AH-Z(D20)
/(L20)/(D21)/(D22)/B5/(G3)

Sheet 2/2

Revision status: E from: 04/2022