

**Materials / Surfaces:**

Input flange: Aluminum / untreated  
 Housing: Steel / heat-treated and post-oxidized (black)  
 Output flange: Steel / untreated

**Hints:**

Please pay attention to the operating and mounting instructions.  
 Subject to modifications.

Variables on the drawing are dependent upon the motor.  
 The given dimensions are exemplary.

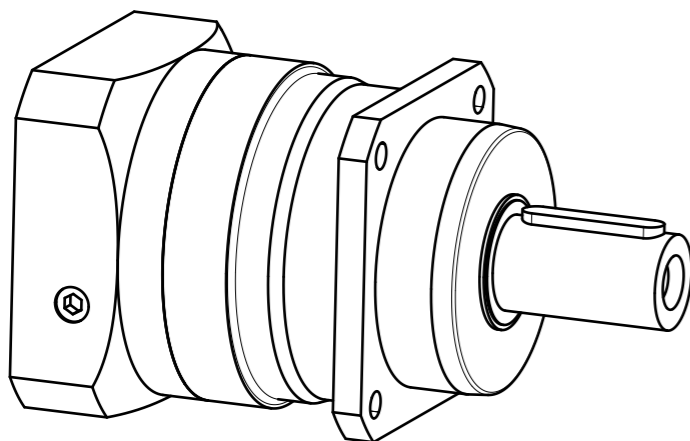

	Scale: 1:2	DIN A3	ISO
	Revision status: E from: 04/2022		
	Changed revision status: D from: 03/2020		
General tolerance DIN ISO 2768-cL	PSN115-aii-SSSA3AF-Z(D20) /(L20)/(D21)/(D22)/B5/(G3)		
Neugart GmbH Keltenstr. 16 D-77971 Kippenheim			Sheet 1/2

General gearbox data	Character	Unit	
Planetary gearbox - gearing type	-	-	Helical teeth
Rotation direction	-	-	Input and output in the same direction
Number of stages	p	-	1-stage
Output shaft bearing	-	-	Tapered roller bearing
Service life (L10h)	$t_L$	h	20.000
Max. operating temperature	$T_{min} / T_{max}$	°C	-25 / +90
Protection class	-	-	IP 65
Lubrication (Lifetime lubrication)	-	-	Standard lubrication (Castrol Optigear Synthetic 800/220)
Installation position	-	-	Any
Max. bending moment based on the gearbox input flange (for motor weight) (1)	$M_b$	Nm	80
Motor shaft concentricity / Coaxiality and axial runout Motor flange	-	-	0,02 / 0,05 (Measuring methods according to DIN EN 50347)
Required motor shaft tolerance	-	-	j6; k6
Min. permissible motor shaft length	$L_{20 min}$	mm	29
Reference operating mode	-	-	S1
Reference operating factor	$K_A$	-	1
Reference speed	$n_2$	rpm	100
Reference ambient temperature	$T_{Amb}$	°C	20
Radial force for output bearing based on shaft center after L10h=20,000h with Fa=0N	$F_r 20.000h$	N	6000
Axial force for output bearing based on gearbox axis after L10h=20,000h with Fr=0N	$F_a 20.000h$	N	8000
Radial force for output bearing based on shaft center after L10h=30,000h with Fa=0N	$F_r 30.000h$	N	5400
Axial force for output bearing based on gearbox axis after L10h=30,000h with Fr=0N	$F_a 30.000h$	N	7000
Maximum radial force based on shaft center and T2=0Nm	$F_r Max$	N	6000
Maximum axial force based on gearbox axis and T2=0Nm	$F_a Max$	N	8000

$$(1) \text{ Max. motor weight* in kg} = \frac{0.2 \times M_b}{\text{motor length in m}}$$

\* with symmetrically distributed motor weight  
\* with horizontal and stationary mounting

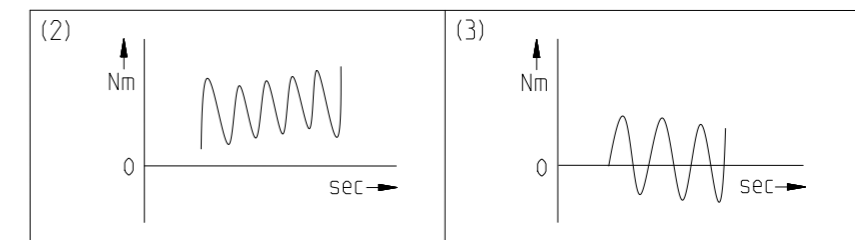

Ratio-dependent gearbox data	Character	Unit						
Ratio	aii	-	3	4	5	7	8	10
Nominal output torque No alternating torque (2)	$T_{2N}$	Nm	135	180	175	175	155	140
Nominal output torque Alternating torque permitted for 10,000,000 load changes (3)	$T_{2N 10Mio}$	Nm	135	180	175	175	155	140
Nominal output torque Alternating torque permitted for 100,000,000 load changes (3)	$T_{2N 100Mio}$	Nm	135	180	175	175	155	140
Max. output torque for 30,000 output shaft rotations (2)	$T_{2max}$	Nm	216	288	280	280	248	224
Emergency stop torque permitted 1000 times	$T_{2Stop}$	Nm	490	650	650	340	380	480
Average idle torque for $n_1=3,000$ rpm and 20 °C gearbox temperature	$T_0$	Nm	2,7	2,5	1,7	1,1	0,95	0,75
Average thermal input speed at 50% $T_{2N}$ , S1, and $T_{Amb}$ Operating temperature may not be exceeded!	$n_{1N 50\%}$	rpm	2000	2250	2750	3500	3500	3500
Average thermal input speed at 100% $T_{2N}$ , S1, and $T_{Amb}$ Operating temperature may not be exceeded!	$n_{1N 100\%}$	rpm	1900	2050	2500	3250	3500	3500
Max. mechanical input speed Operating temperature may not be exceeded!	$n_1 Limit$	rpm	8500	8500	8500	8500	8500	8500
Torsional backlash based on output shaft	$j_t$	arcmin	< 3	< 3	< 3	< 3	< 3	< 3
Torsional stiffness based on output shaft	$c_g$	Nm/arcmin	28	33,5	33	31,5	31,5	30,5
Efficiency at $T_{2N}$ , gearbox temperature 70 °C and $n_1=1,000$ rpm	$\eta$	%	98	98	98	98	97	97
Running noise at $n_1=3,000$ rpm without load at a distance of 1m	$Q_g$	dB(A)	69	63	63	63	63	63
Gearbox weight	$m_G$	kg	7,4	7	7,1	7,1	7,1	7,1
Mass moment of inertia based on clamping system diameter input	J	kgcm <sup>2</sup>	2,775	1,847	1,485	1,273	1,208	1,147

Subject to modifications.



PSN115-aii-SSSA3AF-Z(D20)  
/(L20)/(D21)/(D22)/B5/(G3)

Sheet 2/2

Revision status: E from: 04/2022