

Flange output shaft (similar ISO 9409-1)

Materials / Surfaces:

Input flange: Aluminum / untreated
 Housing: Steel / heat-treated and post-oxidized (black)
 Output flange: Steel / untreated

Hints:

Please pay attention to the operating and mounting instructions.
 Subject to modifications.

Variables on the drawing are dependent upon the motor.
 The given dimensions are exemplary.

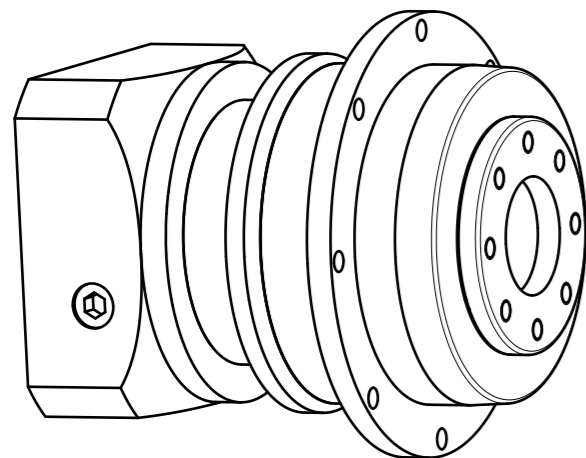

	Scale: 7:10	DIN A3	ISO
	Revision status: H from: 04/2022		
	Changed revision status: G from: 02/2020		
General tolerance DIN ISO 2768-cL	PSFN090-bii-SSSD3AE-Z(D20) /(L20)/(D21)/(D22)/B5/(G3)		
Neugart GmbH Keltenstr. 16 D-77971 Kippenheim			Sheet 1/2

General gearbox data	Character	Unit	
Planetary gearbox - gearing type	-	-	Helical teeth
Rotation direction	-	-	Input and output in the same direction
Number of stages	p	-	2-stage
Output shaft bearing	-	-	Inclined roller bearings
Service life (L10h)	t_L	h	20.000
Max. operating temperature	T_{min} / T_{max}	°C	-25 / +90
Protection class	-	-	IP 65
Lubrication (Lifetime lubrication)	-	-	Standard lubrication (Castrol Optigear Synthetic 800/220)
Installation position	-	-	Any
Max. bending moment based on the gearbox input flange (for motor weight) (1)	M_b	Nm	18
Motor shaft concentricity / Coaxiality and axial runout Motor flange	-	mm	0,02 / 0,04 (Measuring methods according to DIN EN 50347)
Required motor shaft tolerance	-	-	j6; k6
Min. permissible motor shaft length	$L_{20 min}$	mm	28
Reference operating mode	-	-	S1
Reference operating factor	K_A	-	1
Reference speed	n_2	rpm	100
Reference ambient temperature	T_{Amb}	°C	20
Radial force for output bearing based on shaft end after L10h=20,000h with Fa=0N	$F_r 20.000h$	N	3950
Axial force for output bearing based on gearbox axis after L10h=20,000h with Fr=0N	$F_a 20.000h$	N	8200
Radial force for output bearing based on shaft end after L10h=30,000h with Fa=0N	$F_r 30.000h$	N	3500
Axial force for output bearing based on gearbox axis after L10h=30,000h with Fr=0N	$F_a 30.000h$	N	7200
Maximum radial force based on shaft end and T2=0Nm	$F_r Max$	N	3950
Maximum axial force based on gearbox axis and T2=0Nm	$F_a Max$	N	8200

$$(1) \text{ Max. motor weight* in kg} = \frac{0,2 \times M_b}{\text{motor length in m}}$$

- * with symmetrically distributed motor weight
- * with horizontal and stationary mounting

Ratio-dependent gearbox data	Character	Unit								
Ratio	bii	-	16	20	25	35	40	50	70	100
Nominal output torque	T_{2N}	Nm	80	80	80	80	80	80	78	59
Max. output torque for 30,000 output shaft rotations	T_{2max}	Nm	128	128	128	128	128	128	125	94
Emergency stop torque permitted 1000 times	T_{2stop}	Nm	300	300	300	300	300	300	175	200
Average idle torque for $n_1=3,000$ rpm and 20 °C gearbox temperature	T_0	Nm	0,65	0,55	0,5	0,4	0,35	0,3	0,3	0,3
Average thermal input speed at 50% T2N, S1, and T_Amb Operating temperature may not be exceeded!	$n_{1N 50\%}$	rpm	4500	4500	4500	4500	4500	4500	4500	4500
Average thermal input speed at 100% T2N, S1, and T_Amb Operating temperature may not be exceeded!	$n_{1N 100\%}$	rpm	4500	4500	4500	4500	4500	4500	4500	4500
Max. mechanical input speed Operating temperature may not be exceeded!	$n_{1 Limit}$	rpm	14000	14000	14000	14000	14000	14000	14000	14000
Torsional backlash based on output shaft	j_t	arcmin	< 5	< 5	< 5	< 5	< 5	< 5	< 5	< 5
Torsional stiffness based on output shaft	c_g	Nm/arcmin	30,5	31	31,5	30,5	28,5	30	24	21
Efficiency at T2N, gearbox temperature 70 °C and $n_1=1,000$ rpm	η	%	95	95	95	94	94	93	91	86
Running noise at $n_1=3,000$ rpm without load at a distance of 1m	Q_g	dB(A)	58	58	58	58	58	58	58	58
Gearbox weight	m_G	kg	4	4	4	4	4,1	4,1	4,1	4,1
Mass moment of inertia based on clamping system diameter input	J	kgcm ²	0,454	0,423	0,418	0,395	0,385	0,383	0,382	0,382



PSFN090-bii-SSSD3AE-Z(D20)
/(L20)/(D21)/(D22)/B5/(G3)

Sheet 2/2

Subject to modifications.

Revision status: H from: 04/2022