

Flange output shaft (similar ISO 9409-1)

Materials / Surfaces:

Input flange: Aluminum / untreated
 Housing: Steel / heat-treated and post-oxidized (black)
 Output flange: Steel / untreated

Hints:

Please pay attention to the operating and mounting instructions.
 Subject to modifications.

Variables on the drawing are dependent upon the motor.
 The given dimensions are exemplary.

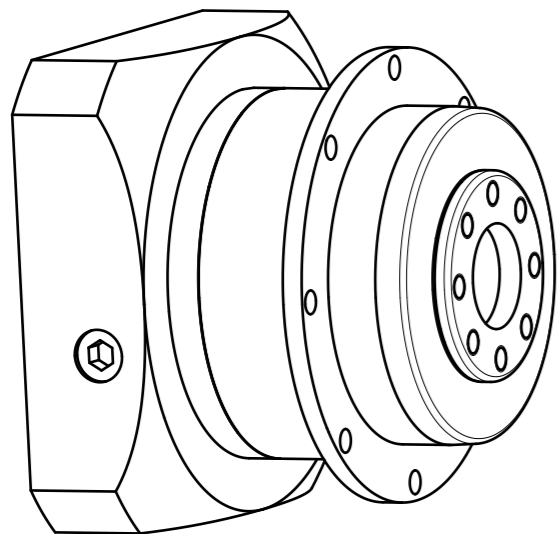

	Scale: 9:10	DIN A3	ISO
	Revision status: H from: 04/2022		
	Changed revision status: G from: 02/2020		
General tolerance DIN ISO 2768-cl	PSFN064-aii-SSSD3AD-Z(D20) /(L20)/(D21)/(D22)/B5/(G3)		
Neugart GmbH Keltenstr. 16 D-77971 Kippenheim			Sheet 1/2

General gearbox data	Character	Unit	
Planetary gearbox - gearing type	-	-	Helical teeth
Rotation direction	-	-	Input and output in the same direction
Number of stages	p	-	1-stage
Output shaft bearing	-	-	Inclined roller bearings
Service life (L10h)	t _L	h	20.000
Max. operating temperature	T _{min} / T _{max}	°C	-25 / +90
Protection class	-	-	IP 65
Lubrication (Lifetime lubrication)	-	-	Standard lubrication (Castrol Optigear Synthetic 800/220)
Installation position	-	-	Any
Max. bending moment based on the gearbox input flange (for motor weight) (1)	M _b	Nm	18
Motor shaft concentricity / Coaxiality and axial runout Motor flange	-	mm	0,02 / 0,04 (Measuring methods according to DIN EN 50347)
Required motor shaft tolerance	-	-	j6; k6
Min. permissible motor shaft length	L _{20 min}	mm	22
Reference operating mode	-	-	S1
Reference operating factor	K _A	-	1
Reference speed	n ₂	rpm	100
Reference ambient temperature	T _{Amb}	°C	20
Radial force for output bearing based on shaft end after L10h=20,000h with Fa=0N	F _{r 20.000h}	N	2150
Axial force for output bearing based on gearbox axis after L10h=20,000h with Fr=0N	F _{a 20.000h}	N	4300
Radial force for output bearing based on shaft end after L10h=30,000h with Fa=0N	F _{r 30.000h}	N	1900
Axial force for output bearing based on gearbox axis after L10h=30,000h with Fr=0N	F _{a 30.000h}	N	3800
Maximum radial force based on shaft end and T2=0Nm	F _{r Max}	N	2150
Maximum axial force based on gearbox axis and T2=0Nm	F _{a Max}	N	4300

$$(1) \text{ Max. motor weight* in kg} = \frac{0,2 \times M_b}{\text{motor length in m}}$$

- * with symmetrically distributed motor weight
- * with horizontal and stationary mounting

Ratio-dependent gearbox data	Character	Unit					
Ratio	aii	-	4	5	7	8	10
Nominal output torque	T _{2N}	Nm	39	40	37	39	28
Max. output torque for 30,000 output shaft rotations	T _{2max}	Nm	62	64	59	62	45
Emergency stop torque permitted 1000 times	T _{2stop}	Nm	120	130	80	90	90
Average idle torque for n1=3,000 rpm and 20 °C gearbox temperature	T ₀	Nm	0,65	0,5	0,35	0,3	0,25
Average thermal input speed at 50% T2N, S1, and T_Amb Operating temperature may not be exceeded!	n _{1N 50%}	rpm	3200	3800	4500	4500	4500
Average thermal input speed at 100% T2N, S1, and T_Amb Operating temperature may not be exceeded!	n _{1N 100%}	rpm	3000	3600	4500	4500	4500
Max. mechanical input speed Operating temperature may not be exceeded!	n _{1 Limit}	rpm	14000	14000	14000	14000	14000
Torsional backlash based on output shaft	j _t	arcmin	< 3	< 3	< 3	< 3	< 3
Torsional stiffness based on output shaft	c _g	Nm/arcmin	12,2	12,8	10,8	11	8,3
Efficiency at T2N, gearbox temperature 70 °C and n1=1,000rpm	η	%	97	97	96	96	95
Running noise at n1=3,000 rpm without load at a distance of 1m	Q _g	dB(A)	57	57	57	57	57
Gearbox weight	m _G	kg	1,6	1,6	1,6	1,65	1,65
Mass moment of inertia based on clamping system diameter input	J	kgcm ²	0,21	0,183	0,161	0,157	0,149



PSFN064-aii-SSSD3AD-Z(D20)
/(L20)/(D21)/(D22)/B5/(G3)

Sheet 2/2

Subject to modifications.

Revision status: H from: 04/2022