

**Materials / Surfaces:**

Input flange: Aluminum / Untreated  
 Housing: Steel / heat treated and post-oxidized (black)  
 Output flange: Aluminum / Untreated

**Hints:**

Please pay attention to the operating and mounting instructions.  
 Subject to modifications.

Variables on the drawing are dependent upon the motor.  
 The given dimensions are exemplary.

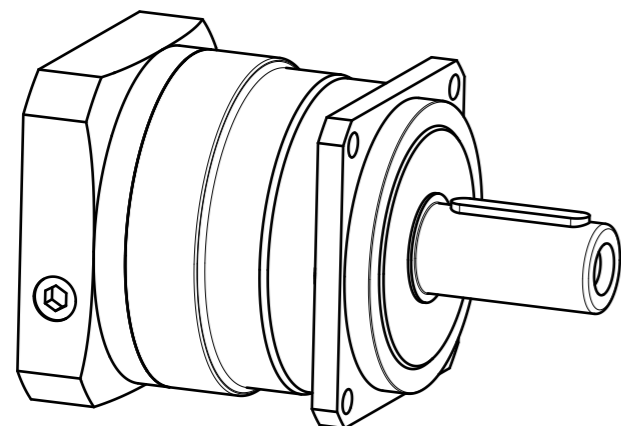

|   |  |        |           |
|---|--|--------|-----------|
|  | Scale: 2:5   | DIN A3 | ISO       |
|   | Revision status: C from: 01/2022                         |        |           |
|   | Changed revision status: A from: 06/2017                 |        |           |
| General tolerance<br>DIN ISO 2768-cL  | PSBN142-aii-SSSA3AG-Z(D20)<br>/(L20)/(D21)/(D22)/B5/(G3) |        |           |
| Neugart GmbH<br>Keltenstr. 16<br>D-77971 Kippenheim                                   |  |        | Sheet 1/2 |

| General gearbox data  |                                     | Unit |   |
|---|-------------------------------------|------|---|
| Planetary gearbox - gearing type  | -                                   | -    | Helical teeth   |
| Rotation direction  | -                                   | -    | Input and output in the same direction                    |
| Number of stages  | p                                   | -    | 1-stage   |
| Output shaft bearing  | -                                   | -    | Deep groove ball bearing                                  |
| Service life (L10h)   | -                                   | h    | 20.000  |
| Max. operating temperature  | T <sub>min</sub> / T <sub>max</sub> | °C   | -25 / +90   |
| Protection class  | -                                   | -    | IP 65   |
| Lubrication (lifetime lubrication)  | -                                   | -    | Standard lubrication (Castrol Optigear Synthetic 800/220) |
| Installation position   | -                                   | -    | Any   |
| Max. bending moment based on the gearbox input flange (for motor weight) (1)        | M <sub>b</sub>                      | Nm   | 180   |
| Motor shaft concentricity / Coaxiality and axial runout Motor flange                | -                                   | -    | 0,02 / 0,05 (Measuring methods according to DIN EN 50347) |
| Required motor shaft tolerance  | -                                   | -    | j6; k6  |
| Min. permissible motor shaft length   | L <sub>20 min</sub>                 | mm   | 29,5  |
| Reference operating mode  | -                                   | -    | S1  |
| Reference operating factor  | K <sub>A</sub>                      | -    | 1   |
| Reference speed   | n <sub>2</sub>                      | rpm  | 100   |
| Reference ambient temperature   | T <sub>Amb</sub>                    | °C   | 20  |
| Radial force for output bearing based on shaft center after L10h=20,000h with Fa=0N | F <sub>r 20.000h</sub>              | N    | 5800 Different radial force at (6): 4200                  |
| Axial force for output bearing based on gearbox axis after L10h=20,000h with Fr=0N  | F <sub>a 20.000h</sub>              | N    | 9400  |
| Radial force for output bearing based on shaft center after L10h=30,000h with Fa=0N | F <sub>r 30.000h</sub>              | N    | 5100 Different radial force at (6): 3700                  |
| Axial force for output bearing based on gearbox axis after L10h=30,000h with Fr=0N  | F <sub>a 30.000h</sub>              | N    | 7700  |
| Maximum radial force based on shaft center and T2=0Nm                               | F <sub>r Max</sub>                  | N    | 9500  |
| Maximum axial force based on gearbox axis and T2=0Nm                                | F <sub>a Max</sub>                  | N    | 9600  |

$$(1) \text{ Max. motor weight* in kg} = \frac{0,2 \times M_b}{\text{motor length in m}}$$

- \* with symmetrically distributed motor weight
- \* with horizontal and stationary mounting

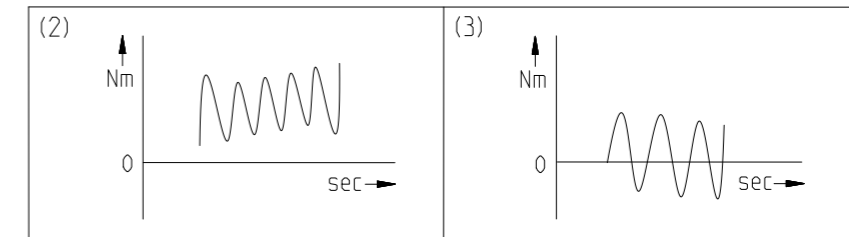

| Ratio-dependent gearbox data   | Character              | Unit              |                  |       |       |       |       |       |
|--|------------------------|-------------------|------------------|-------|-------|-------|-------|-------|
| Ratio  | aii                    | -                 | 3 <sup>(6)</sup> | 4     | 5     | 7     | 8     | 10    |
| Nominal output torque<br>No alternating torque (2)   | T <sub>2N</sub>        | Nm                | 380              | 470   | 405   | 355   | 350   | 305   |
| Nominal output torque<br>Alternating torque permitted for 10,000,000 load changes (3)                | T <sub>2N 10Mio</sub>  | Nm                | 341              | 341   | 341   | 341   | 341   | 305   |
| Nominal output torque<br>Alternating torque permitted for 100,000,000 load changes (3)               | T <sub>2N 100Mio</sub> | Nm                | 271              | 271   | 271   | 271   | 271   | 271   |
| Max. output torque<br>for 30,000 output shaft rotations (2)  | T <sub>2max</sub>      | Nm                | 608              | 752   | 648   | 568   | 560   | 488   |
| Emergency stop torque<br>permitted 1000 times  | T <sub>2Stop</sub>     | Nm                | 1250             | 1650  | 1650  | 1300  | 1100  | 600   |
| Average idle torque<br>for n1=3,000 rpm and 20 °C gearbox temperature                                | T <sub>0</sub>         | Nm                | 6,6              | 4,5   | 3     | 1,9   | 1,6   | 1,3   |
| Average thermal input speed at 50% T2N, S1, and T_Amb<br>Operating temperature may not be exceeded!  | n <sub>1N 50%</sub>    | rpm               | 1600             | 1950  | 2350  | 3150  | 3450  | 3500  |
| Average thermal input speed at 100% T2N, S1, and T_Amb<br>Operating temperature may not be exceeded! | n <sub>1N 100%</sub>   | rpm               | 1450             | 1650  | 2100  | 2800  | 3100  | 3500  |
| Max. mechanical input speed<br>Operating temperature may not be exceeded!                            | n <sub>1 Limit</sub>   | rpm               | 6500             | 6500  | 6500  | 6500  | 6500  | 6500  |
| Torsional backlash<br>based on output shaft  | j <sub>t</sub>         | arcmin            | < 3              | < 3   | < 3   | < 3   | < 3   | < 3   |
| Torsional stiffness<br>based on output shaft   | c <sub>g</sub>         | Nm/arcmin         | 68               | 73    | 73    | 66    | 65    | 59,5  |
| Efficiency<br>at T2N, gearbox temperature 70 °C and n1=1,000rpm                                      | η                      | %                 | 96               | 96    | 96    | 96    | 95    | 95    |
| Running noise<br>at n1=3,000 rpm without load at a distance of 1m                                    | Q <sub>g</sub>         | dB(A)             | 71               | 66    | 66    | 66    | 66    | 66    |
| Gearbox weight   | m <sub>G</sub>         | kg                | 13,7             | 13,4  | 13,5  | 13,6  | 13,6  | 13,7  |
| Mass moment of inertia<br>based on clamping system diameter input                                    | J                      | kgcm <sup>2</sup> | 14,44            | 9,792 | 8,335 | 7,147 | 6,873 | 6,539 |

Subject to modifications.



PSBN142-aii-SSSA3AG-Z(D20)  
/(L20)/(D21)/(D22)/B5/(G3)

Sheet 2/2

Revision status: C from: 01/2022