

Materials / Surfaces:

Input flange: Aluminum / Untreated
 Housing: Steel / heat treated and post-oxidized (black)
 Output flange: Aluminum / Untreated

Hints:

Please pay attention to the operating and mounting instructions.
 Subject to modifications.

Variables on the drawing are dependent upon the motor.
 The given dimensions are exemplary.

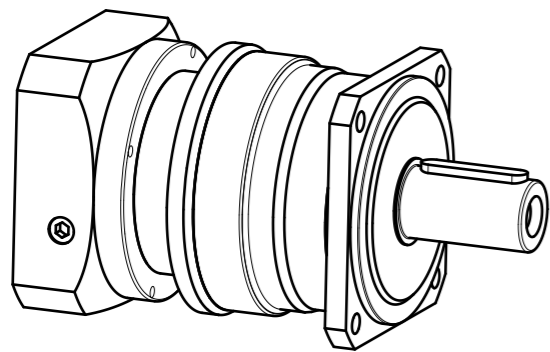

	Scale: 2:5	DIN A3	ISO
	Revision status: C from: 01/2022		
	Changed revision status: B from: 06/2017		
General tolerance DIN ISO 2768-cL	PSBN115-bii-SSSA3AF-Z(D20) /(L20)/(D21)/(D22)/B5/(G3)		
Neugart GmbH Keltenstr. 16 D-77971 Kippenheim			Sheet 1/2

General gearbox data		Unit	
Planetary gearbox - gearing type	-	-	Helical teeth
Rotation direction	-	-	Input and output in the same direction
Number of stages	p	-	2-stage
Output shaft bearing	-	-	Deep groove ball bearing
Service life (L10h)	-	h	20.000
Max. operating temperature	T _{min} / T _{max}	°C	-25 / +90
Protection class	-	-	IP 65
Lubrication (lifetime lubrication)	-	-	Standard lubrication (Castrol Optigear Synthetic 800/220)
Installation position	-	-	Any
Max. bending moment based on the gearbox input flange (for motor weight) (1)	M _b	Nm	38
Motor shaft concentricity / Coaxiality and axial runout Motor flange	-	-	0,02 / 0,05 (Measuring methods according to DIN EN 50347)
Required motor shaft tolerance	-	-	j6; k6
Min. permissible motor shaft length	L _{20 min}	mm	29
Reference operating mode	-	-	S1
Reference operating factor	K _A	-	1
Reference speed	n ₂	rpm	100
Reference ambient temperature	T _{Amb}	°C	20
Radial force for output bearing based on shaft center after L10h=20,000h with Fa=0N	F _{r 20.000h}	N	2300
Axial force for output bearing based on gearbox axis after L10h=20,000h with Fr=0N	F _{a 20.000h}	N	4400
Radial force for output bearing based on shaft center after L10h=30,000h with Fa=0N	F _{r 30.000h}	N	2000
Axial force for output bearing based on gearbox axis after L10h=30,000h with Fr=0N	F _{a 30.000h}	N	3700
Maximum radial force based on shaft center and T2=0Nm	F _{r Max}	N	4500
Maximum axial force based on gearbox axis and T2=0Nm	F _{a Max}	N	4500

$$(1) \text{ Max. motor weight* in kg} = \frac{0,2 \times M_b}{\text{motor length in m}}$$

- * with symmetrically distributed motor weight
- * with horizontal and stationary mounting

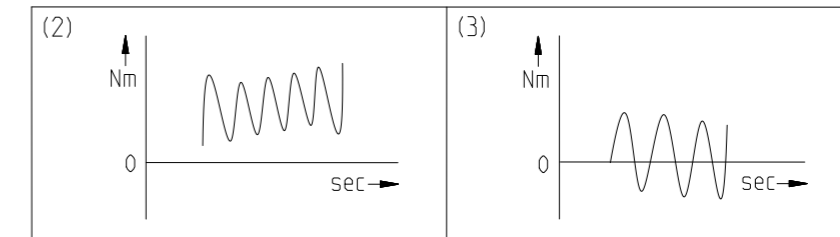

Ratio-dependent gearbox data	Character	Unit										
Ratio	bii	-	12	15	16	20	25	35	40	50	70	100
Nominal output torque No alternating torque (2)	T _{2N}	Nm	135	135	180	180	175	175	180	175	175	140
Nominal output torque Alternating torque permitted for 10,000,000 load changes (3)	T _{2N 10Mio}	Nm	135	135	180	180	175	175	180	175	175	140
Nominal output torque Alternating torque permitted for 100,000,000 load changes (3)	T _{2N 100Mio}	Nm	135	135	180	180	175	175	180	175	175	140
Max. output torque for 30,000 output shaft rotations (2)	T _{2max}	Nm	216	216	288	288	280	280	288	280	280	224
Emergency stop torque permitted 1000 times	T _{2Stop}	Nm	500	500	650	650	650	650	650	650	340	480
Average idle torque for n1=3,000 rpm and 20 °C gearbox temperature	T ₀	Nm	1,2	0,9	1,2	0,9	0,85	0,6	0,5	0,45	0,45	0,45
Average thermal input speed at 50% T2N, S1, and T_Amb Operating temperature may not be exceeded!	n _{1N 50%}	rpm	4500	4500	4500	4500	4500	4500	4500	4500	4500	4500
Average thermal input speed at 100% T2N, S1, and T_Amb Operating temperature may not be exceeded!	n _{1N 100%}	rpm	4500	4500	4500	4500	4500	4500	4500	4500	4500	4500
Max. mechanical input speed Operating temperature may not be exceeded!	n _{1 Limit}	rpm	10000	10000	10000	10000	10000	10000	10000	10000	10000	10000
Torsional backlash based on output shaft	j _t	arcmin	< 5	< 5	< 5	< 5	< 5	< 5	< 5	< 5	< 5	< 5
Torsional stiffness based on output shaft	c _g	Nm/arcmin	26,5	26,5	32,5	32,5	33,5	32,5	30,5	32	31	30,5
Efficiency at T2N, gearbox temperature 70 °C and n1=1,000rpm	η	%	95	94	92	88	97	98	98	97	97	97
Running noise at n1=3,000 rpm without load at a distance of 1m	Q _g	dB(A)	63	63	63	63	63	63	63	63	63	63
Gearbox weight	m _G	kg	7,5	7,5	7,5	7,5	7,6	7,7	7,6	7,7	7,6	7,7
Mass moment of inertia based on clamping system diameter input	J	kgcm ²	1,259	1,14	1,201	1,103	1,089	0,744	0,712	0,708	0,706	0,704

Subject to modifications.



PSBN115-bii-SSSA3AF-Z(D20)
/(L20)/(D21)/(D22)/B5/(G3)

Sheet 2/2

Revision status: C from: 01/2022