

**Materials / Surfaces:**

Input flange: Aluminum / Untreated  
 Housing: Steel / heat treated and post-oxidized (black)  
 Output flange: Aluminum / Untreated

**Hints:**

Please pay attention to the operating and mounting instructions.  
 Subject to modifications.

Variables on the drawing are dependent upon the motor.  
 The given dimensions are exemplary.

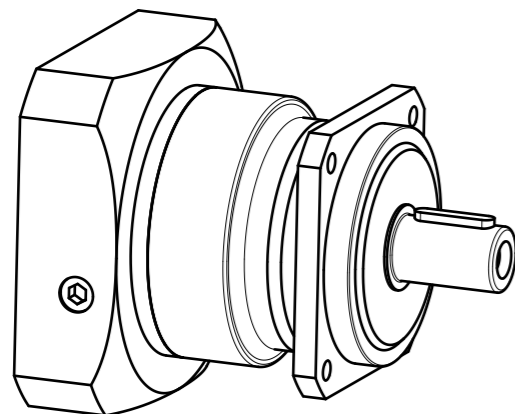

	Scale: 3:5	DIN A3	ISO
	Revision status: C from: 01/2022		
	Changed revision status: B from: 06/2017		
General tolerance DIN ISO 2768-cL	PSBN090-aii-SSSA3AE-Z(D20) /(L20)/(D21)/(D22)/B5/(G3)		
Neugart GmbH Keltenstr. 16 D-77971 Kippenheim			Sheet 1/2

General gearbox data		Unit	
Planetary gearbox - gearing type	-	-	Helical teeth
Rotation direction	-	-	Input and output in the same direction
Number of stages	p	-	1-stage
Output shaft bearing	-	-	Deep groove ball bearing
Service life (L10h)	-	h	20.000
Max. operating temperature	T <sub>min</sub> / T <sub>max</sub>	°C	-25 / +90
Protection class	-	-	IP 65
Lubrication (lifetime lubrication)	-	-	Standard lubrication (Castrol Optigear Synthetic 800/220)
Installation position	-	-	Any
Max. bending moment based on the gearbox input flange (for motor weight) (1)	M <sub>b</sub>	Nm	38
Motor shaft concentricity / Coaxiality and axial runout Motor flange	-	-	0,02 / 0,04 (Measuring methods according to DIN EN 50347)
Required motor shaft tolerance	-	-	j6; k6
Min. permissible motor shaft length	L <sub>20 min</sub>	mm	29
Reference operating mode	-	-	S1
Reference operating factor	K <sub>A</sub>	-	1
Reference speed	n <sub>2</sub>	rpm	100
Reference ambient temperature	T <sub>Amb</sub>	°C	20
Radial force for output bearing based on shaft center after L10h=20,000h with Fa=0N	F <sub>r 20.000h</sub>	N	1900
Axial force for output bearing based on gearbox axis after L10h=20,000h with Fr=0N	F <sub>a 20.000h</sub>	N	3000
Radial force for output bearing based on shaft center after L10h=30,000h with Fa=0N	F <sub>r 30.000h</sub>	N	1700
Axial force for output bearing based on gearbox axis after L10h=30,000h with Fr=0N	F <sub>a 30.000h</sub>	N	2500
Maximum radial force based on shaft center and T2=0Nm	F <sub>r Max</sub>	N	3100
Maximum axial force based on gearbox axis and T2=0Nm	F <sub>a Max</sub>	N	2800

$$(1) \text{ Max. motor weight* in kg} = \frac{0,2 \times M_b}{\text{motor length in m}}$$

- \* with symmetrically distributed motor weight
- \* with horizontal and stationary mounting

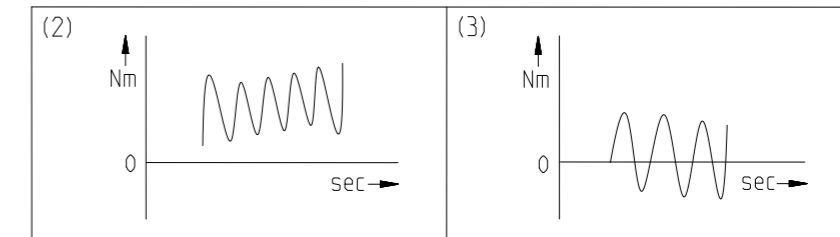

Ratio-dependent gearbox data	Character	Unit						
Ratio	aii	-	3	4	5	7	8	10
Nominal output torque No alternating torque (2)	T <sub>2N</sub>	Nm	54	80	80	78	75	59
Nominal output torque Alternating torque permitted for 10,000,000 load changes (3)	T <sub>2N 10Mio</sub>	Nm	54	76	76	76	75	59
Nominal output torque Alternating torque permitted for 100,000,000 load changes (3)	T <sub>2N 100Mio</sub>	Nm	54	60	60	60	60	59
Max. output torque for 30,000 output shaft rotations (2)	T <sub>2max</sub>	Nm	86	128	128	125	120	94
Emergency stop torque permitted 1000 times	T <sub>2Stop</sub>	Nm	210	280	280	175	200	200
Average idle torque for n1=3,000 rpm and 20 °C gearbox temperature	T <sub>0</sub>	Nm	1,2	1	0,9	0,5	0,45	0,4
Average thermal input speed at 50% T2N, S1, and T_Amb Operating temperature may not be exceeded!	n <sub>1N 50%</sub>	rpm	3400	3700	3900	4500	4500	4500
Average thermal input speed at 100% T2N, S1, and T_Amb Operating temperature may not be exceeded!	n <sub>1N 100%</sub>	rpm	3200	3400	3600	4500	4500	4500
Max. mechanical input speed Operating temperature may not be exceeded!	n <sub>1 Limit</sub>	rpm	10000	10000	10000	10000	10000	10000
Torsional backlash based on output shaft	j <sub>t</sub>	arcmin	< 3	< 3	< 3	< 3	< 3	< 3
Torsional stiffness based on output shaft	c <sub>g</sub>	Nm/arcmin	10,7	12,8	13	12	12,2	10,9
Efficiency at T2N, gearbox temperature 70 °C and n1=1,000rpm	η	%	95	95	96	96	95	95
Running noise at n1=3,000 rpm without load at a distance of 1m	Q <sub>g</sub>	dB(A)	64	58	58	58	58	58
Gearbox weight	m <sub>G</sub>	kg	3,5	3,5	3,4	3,4	3,4	3,4
Mass moment of inertia based on clamping system diameter input	J	kgcm <sup>2</sup>	0,895	0,643	0,548	0,474	0,456	0,436

Subject to modifications.



PSBN090-aii-SSSA3AE-Z(D20)  
/(L20)/(D21)/(D22)/B5/(G3)

Sheet 2/2

Revision status: C from: 01/2022