

Materials / Surfaces:

Input flange: Aluminum / untreated
Housing: Steel / heat-treated and post-oxidized (black)
Output flange: Steel / heat-treated and post-oxidized (black)

Hints:

Please pay attention to the operating and mounting instructions.
Subject to modifications.

Variables on the drawing are dependent upon the motor.
The given dimensions are exemplary.

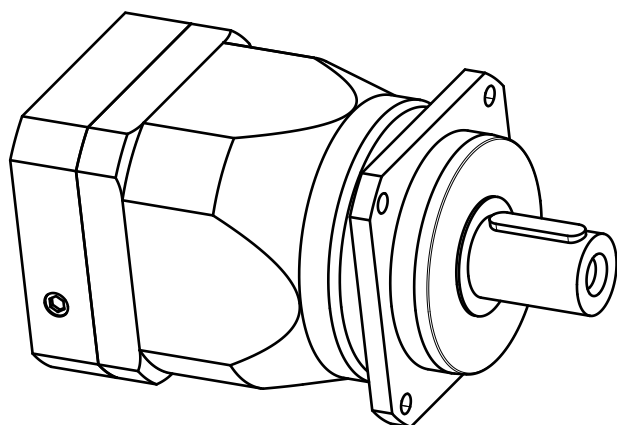

	Scale: 3:10	DIN A3	ISO
	Revision status: L from: 05/2022		
	Changed revision status: K from: 07/2020		
General tolerance DIN ISO 2768-cL	PLN190-bii-SSSA3AK-Y(D20) /(L20)/(D21)/(D22)/B5/(G3)		
Neugart GmbH Keltenstr. 16 D-77971 Kippenheim			Sheet 1/2

General gearbox data	Character	Unit	
Planetary gearbox - gearing type	-	-	Straight teeth
Rotation direction	-	-	Input and output in the same direction
Number of stages	p	-	2-stage
Output shaft bearing	-	-	Tapered roller bearing
Service life (L10h)	t_L	h	20.000
Max. operating temperature	T_{min} / T_{max}	°C	-25 / +90
Protection class	-	-	IP 65
Lubrication (lifetime lubrication)	-	-	Standard lubrication (Castrol Optigear Synthetic 800/150)
Installation position	-	-	Any
Max. bending moment based on the gearbox input flange (for motor weight) (1)	M_b	Nm	300
Motor shaft concentricity / Coaxiality and axial runout Motor flange	-	-	0,015 / 0,03 (Measuring methods according to DIN EN 50347)
Required motor shaft tolerance	-	-	j6; k6
Min. permissible motor shaft length	$L_{20 min}$	mm	36
Reference operating mode	-	-	S1
Reference operating factor	K_A	-	1
Reference speed	n_2	rpm	100
Reference ambient temperature	T_{Amb}	°C	20
Radial force for output bearing based on shaft center after L10h=20,000h with Fa=0N	$F_r 20.000h$	N	21000
Axial force for output bearing based on gearbox axis after L10h=20,000h with Fr=0N	$F_a 20.000h$	N	21000
Radial force for output bearing based on shaft center after L10h=30,000h with Fa=0N	$F_r 30.000h$	N	18000
Axial force for output bearing based on gearbox axis after L10h=30,000h with Fr=0N	$F_a 30.000h$	N	18500
Maximum radial force based on shaft end and T2=0Nm	$F_r Max$	N	21000
Maximum axial force based on gearbox axis and T2=0Nm	$F_a Max$	N	21000

$$(1) \text{ Max. motor weight* in kg} = \frac{0,2 \times M_b}{\text{motor length in m}}$$

- * with symmetrically distributed motor weight
- * with horizontal and stationary mounting

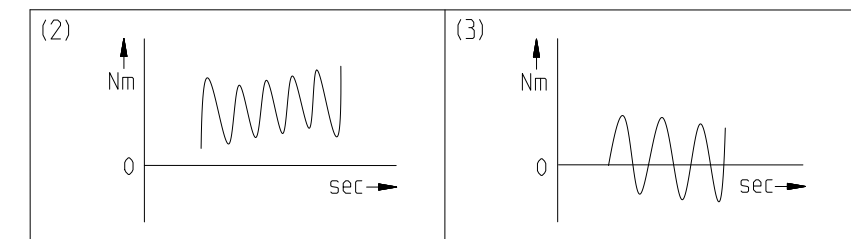

Ratio-dependent gearbox data	Character	Unit									
Ratio	bii	-	12	15	16	20	25	32	40	64	100
Nominal output torque No alternating torque (2)	T_{2N}	Nm	1500	1500	1800	1800	1800	1800	1800	1000	630
Nominal output torque Alternating torque permitted for 10,000,000 load changes (3)	$T_{2N 10Mio}$	Nm	693	693	693	693	693	693	693	693	630
Nominal output torque Alternating torque permitted for 100,000,000 load changes (3)	$T_{2N 100Mio}$	Nm	550	550	550	550	550	550	550	550	550
Max. output torque for 30,000 output shaft rotations	T_{2max}	Nm	2400	2400	2880	2880	2880	2880	2880	1600	1008
Emergency stop torque permitted 1000 times	T_{2stop}	Nm	3000	3000	3600	3600	3600	3600	3600	2600	1350
Average idle torque for $n_1=3,000$ rpm and 20 °C gearbox temperature	T_0	Nm	13,9	8,95	13,5	8,65	8,3	3,9	3,75	3,55	2,85
Average thermal input speed at 50% T_{2N} , S1, and T_{Amb} Operating temperature may not be exceeded!	$n_{1N 50\%}$	rpm	1000	1250	1050	1300	1400	1900	2100	2500	2500
Average thermal input speed at 100% T_{2N} , S1, and T_{Amb} Operating temperature may not be exceeded!	$n_{1N 100\%}$	rpm	750	950	800	1000	1100	1450	1600	2300	2500
Max. mechanical input speed Operating temperature may not be exceeded!	$n_{1 Limit}$	rpm	6000	6000	6000	6000	6000	6000	6000	6000	6000
Torsional backlash based on output shaft	j_t	arcmin	< 5	< 5	< 5	< 5	< 5	< 5	< 5	< 5	< 5
Torsional stiffness based on output shaft	c_g	Nm/arcmin	190	191	190	191	202	190	201	176	169
Efficiency at T_{2N} , gearbox temperature 70 °C and $n_1=1,000$ rpm	η	%	95	95	95	95	95	95	94	90	84
Running noise at $n_1=3,000$ rpm without load at a distance of 1m	Q_g	dB(A)	76	76	76	74	74	74	74	74	74
Gearbox weight	m_G	kg	45,4	45,5	45,4	45,5	45,7	45,9	46	46,3	49,6
Mass moment of inertia based on clamping system diameter input	J	kgcm ²	36,003	29,071	34,782	28,286	28,052	24,536	24,445	24,326	22,43

Subject to modifications.



PLN190-bii-SSSA3AK-Y(D20)
/(L20)/(D21)/(D22)/B5/(G3)

Sheet 2/2

Revision status: L from: 05/2022