

Materials / Surfaces:

Input flange: Aluminum / untreated
 Housing: Steel / heat-treated and post-oxidized (black)
 Output flange: Steel / heat-treated and post-oxidized (black)

Hints:

Please pay attention to the operating and mounting instructions.
 Subject to modifications.

Variables on the drawing are dependent upon the motor.
 The given dimensions are exemplary.

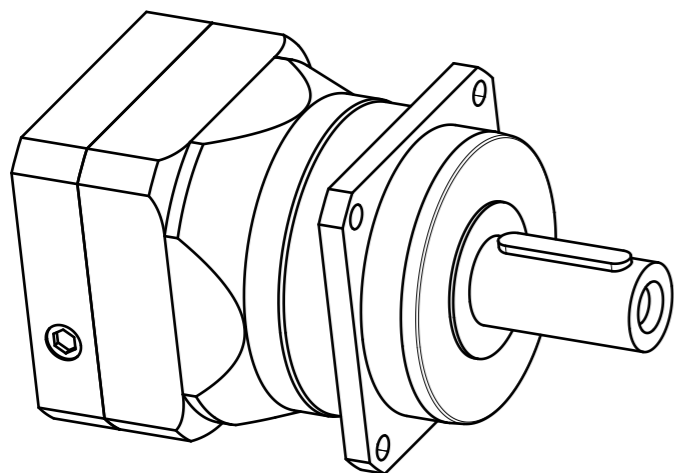

	Scale: 2:5	DIN A3	ISO
	Revision status: L from: 05/2022		
	Changed revision status: K from: 07/2020		
General tolerance DIN ISO 2768-cl	PLN142-aii-SSSA3AG-Y(D20) /(L20)/(D21)/(D22)/B5/(G3)		
Neugart GmbH Keltenstr. 16 D-77971 Kippenheim			Sheet 1/2

General gearbox data	Character	Unit	
Planetary gearbox - gearing type	-	-	Straight teeth
Rotation direction	-	-	Input and output in the same direction
Number of stages	p	-	1-stage
Output shaft bearing	-	-	Tapered roller bearing
Service life (L10h)	t_L	h	20.000
Max. operating temperature	T_{min} / T_{max}	°C	-25 / +90
Protection class	-	-	IP 65
Lubrication (lifetime lubrication)	-	-	Standard lubrication (Castrol Optigear Synthetic 800/150)
Installation position	-	-	Any
Max. bending moment based on the gearbox input flange (for motor weight) (1)	M_b	Nm	180
Motor shaft concentricity / Coaxiality and axial runout Motor flange	-	-	0,015 / 0,03 (Measuring methods according to DIN EN 50347)
Required motor shaft tolerance	-	-	j6; k6
Min. permissible motor shaft length	$L_{20 min}$	mm	27,5
Reference operating mode	-	-	S1
Reference operating factor	K_A	-	1
Reference speed	n_2	rpm	100
Reference ambient temperature	T_{Amb}	°C	20
Radial force for output bearing based on shaft center after L10h=20,000h with Fa=0N	$F_r 20.000h$	N	12500
Axial force for output bearing based on gearbox axis after L10h=20,000h with Fr=0N	$F_a 20.000h$	N	15000
Radial force for output bearing based on shaft center after L10h=30,000h with Fa=0N	$F_r 30.000h$	N	11400
Axial force for output bearing based on gearbox axis after L10h=30,000h with Fr=0N	$F_a 30.000h$	N	13200
Maximum radial force based on shaft end and T2=0Nm	$F_r Max$	N	12500
Maximum axial force based on gearbox axis and T2=0Nm	$F_a Max$	N	15000

$$(1) \text{ Max. motor weight* in kg} = \frac{0,2 \times M_b}{\text{motor length in m}}$$

- * with symmetrically distributed motor weight
- * with horizontal and stationary mounting

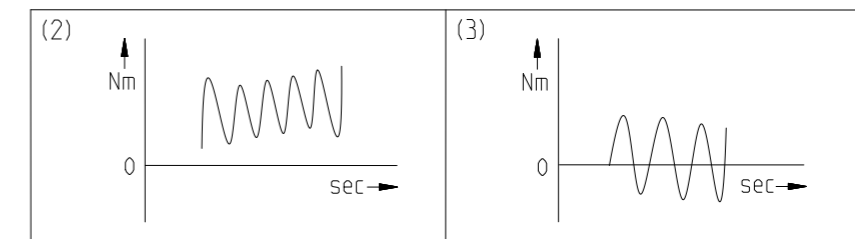

Ratio-dependent gearbox data	Character	Unit							
Ratio	aii	-	3	4	5	7	8	10	
Nominal output torque No alternating torque (2)	T_{2N}	Nm	450	600	750	530	450	305	
Nominal output torque Alternating torque permitted for 10,000,000 load changes (3)	$T_{2N 10Mio}$	Nm	401	401	401	401	401	305	
Nominal output torque Alternating torque permitted for 100,000,000 load changes (3)	$T_{2N 100Mio}$	Nm	319	319	319	319	319	305	
Max. output torque for 30,000 output shaft rotations	T_{2max}	Nm	720	960	1200	848	720	488	
Emergency stop torque permitted 1000 times	T_{2stop}	Nm	975	1300	1500	1300	1000	750	
Average idle torque for $n_1=3,000$ rpm and 20 °C gearbox temperature	T_0	Nm	7,95	6,65	4,45	2,75	2,35	1,85	
Average thermal input speed at 50% T_{2N} , S1, and T_{Amb} Operating temperature may not be exceeded!	$n_{1N 50\%}$	rpm	850	950	1050	1550	1800	2250	
Average thermal input speed at 100% T_{2N} , S1, and T_{Amb} Operating temperature may not be exceeded!	$n_{1N 100\%}$	rpm	700	700	750	1150	1400	1900	
Max. mechanical input speed Operating temperature may not be exceeded!	$n_{1 Limit}$	rpm	6500	6500	6500	6500	6500	6500	
Torsional backlash based on output shaft	j_t	arcmin	< 3	< 3	< 3	< 3	< 3	< 3	
Torsional stiffness based on output shaft	c_g	Nm/arcmin	63	67	71	65	63	61	
Efficiency at T_{2N} , gearbox temperature 70 °C and $n_1=1,000$ rpm	η	%	97	97	98	97	97	96	
Running noise at $n_1=3,000$ rpm without load at a distance of 1m	Q_g	dB(A)	75	72	70	70	70	70	
Gearbox weight	m_G	kg	17,6	16	16,2	16,3	16,3	16,4	
Mass moment of inertia based on clamping system diameter input	J	kgcm ²	15,27	10,502	8,538	7,623	7,337	7,008	

Subject to modifications.



PLN142-aii-SSSA3AG-Y(D20)
/(L20)/(D21)/(D22)/B5/(G3)

Sheet 2/2

Revision status: L from: 05/2022