

Flange output shaft with dowel hole (ISO 9409-1)

Materials / Surfaces:

Input flange: Aluminum / untreated
 Housing: Steel / heat-treated and post-oxidized (black)
 Output flange: Steel / untreated

Hints:

Please pay attention to the operating and mounting instructions.
 Subject to modifications.

Variables on the drawing are dependent upon the motor.
 The givdimensions are exemplary.

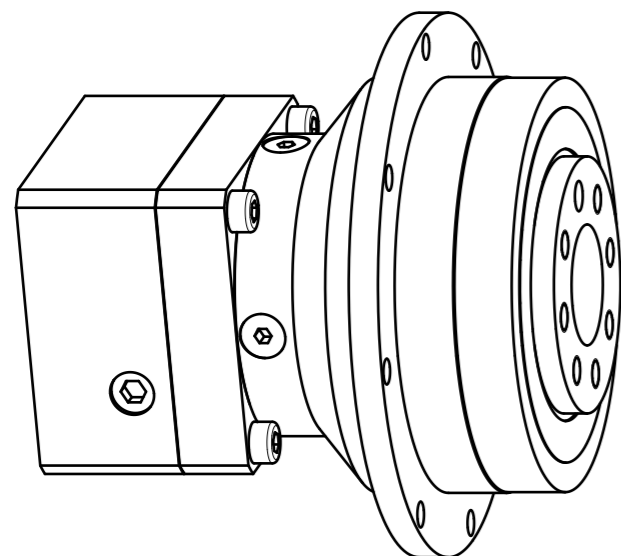

	Scale: 5:4	DIN A3	ISO
	Revision status: I from: 11/2023		
General tolerance DIN ISO 2768-cL	PLFE055-aii-SSSE3AB-Y(D20) /(L20)/(D21)/(D22)/B5/(G3)		
Neugart GmbH Keltenstr. 16 D-77971 Kippenheim			Sheet 1/2

General gearbox data	Character	Unit	
Planetary gearbox - gearing type	-	-	Straight teeth
Rotation direction	-	-	Input and output in the same direction
Number of stages	p	-	1-stage
Output shaft bearing	-	-	Deep groove ball bearing
Service life (L10h)	t _L	h	30.000
Max. operating temperature	T _{min} / T _{max}	°C	-25 / +90
Protection class	-	-	IP 54
Lubrication (lifetime lubrication)	-	-	Standard lubrication (KLübersynth GE 14-112)
Installation position	-	-	Any
Max. bending moment based on the gearbox input flange (for motor weight) (1)	M _b	Nm	4,5
Motor shaft concentricity / Coaxiality and axial runout Motor flange	-	mm	0,03 / 0,06 (Measuring methods according to operating manual)
Required motor shaft tolerance	-	-	j6; k6
Min. permissible motor shaft length	L _{20 min}	mm	17,5
Reference operating mode	-	-	S1
Reference operating factor	K _A	-	1
Reference speed	n ₂	rpm	100
Reference ambient temperature	T _{Amb}	°C	20
Radial force for output bearing based on shaft end after L10h=20,000h with Fa=0N	F _{r 20.000h}	N	550
Axial force for output bearing based on gearbox axis after L10h=20,000h with Fr=0N	F _{a 20.000h}	N	840
Radial force for output bearing based on shaft end after L10h=30,000h with Fa=0N	F _{r 30.000h}	N	480
Axial force for output bearing based on gearbox axis after L10h=30,000h with Fr=0N	F _{a 30.000h}	N	710
Maximum radial force based on shaft end and T2=0Nm	F _{r Max}	N	1150
Maximum axial force based on gearbox axis and T2=0Nm	F _{a Max}	N	1000

$$(1) \text{ Max. motor weight* in kg} = \frac{0,2 \times M_b}{\text{motor length in m}}$$

- * with symmetrically distributed motor weight
- * with horizontal and stationary mounting

Ratio-dependent gearbox data	Character	Unit						
Ratio	aii	-	3	4	5	7	8	10
Nominal output torque	T _{2N}	Nm	11	15	14	8,5	6	5
Max. output torque for 30,000 output shaft rotations	T _{2max}	Nm	17,5	24	22	13,5	10	8
Emergency stop torque permitted 1000 times	T _{2Stop}	Nm	22,5	30	36	26	27	27
Average idle torque for n1=3,000 rpm and 20 °C gearbox temperature	T ₀	Nm	0,25	0,2	0,15	0,1	0,1	0,1
Average thermal input speed at 50% T2N, S1, and T_Amb Operating temperature may not be exceeded!	n _{1N 50%}	rpm	5000	5000	5000	5000	5000	5000
Average thermal input speed at 100% T2N, S1, and T_Amb Operating temperature may not be exceeded!	n _{1N 100%}	rpm	5000	5000	5000	5000	5000	5000
Max. mechanical input speed Operating temperature may not be exceeded!	n _{1 Limit}	rpm	18000	18000	18000	18000	18000	18000
Torsional backlash based on output shaft	j _t	arcmin	< 15	< 15	< 15	< 15	< 15	< 15
Torsional stiffness based on output shaft	c _g	Nm/arcmin	1,7	3,6	4,1	2,6	2,5	2
Efficiency at T2N, gearbox temperature 70 °C and n1=1,000rpm	η	%	96	97	96	94	92	89
Running noise at n1=3,000 rpm without load at a distance of 1m	Q _g	dB(A)	58	58	58	58	58	58
Gearbox weight	m _G	kg	0,7	0,7	0,7	0,7	0,7	0,7
Mass moment of inertia based on clamping system diameter input	J	kgcm ²	0,07	0,047	0,038	0,029	0,027	0,025

Subject to modifications.



PLFE055-aii-SSSE3AB-Y(D20)
/(L20)/(D21)/(D22)/B5/(G3)

Sheet 2/2

Revision status: I from: 11/2023